

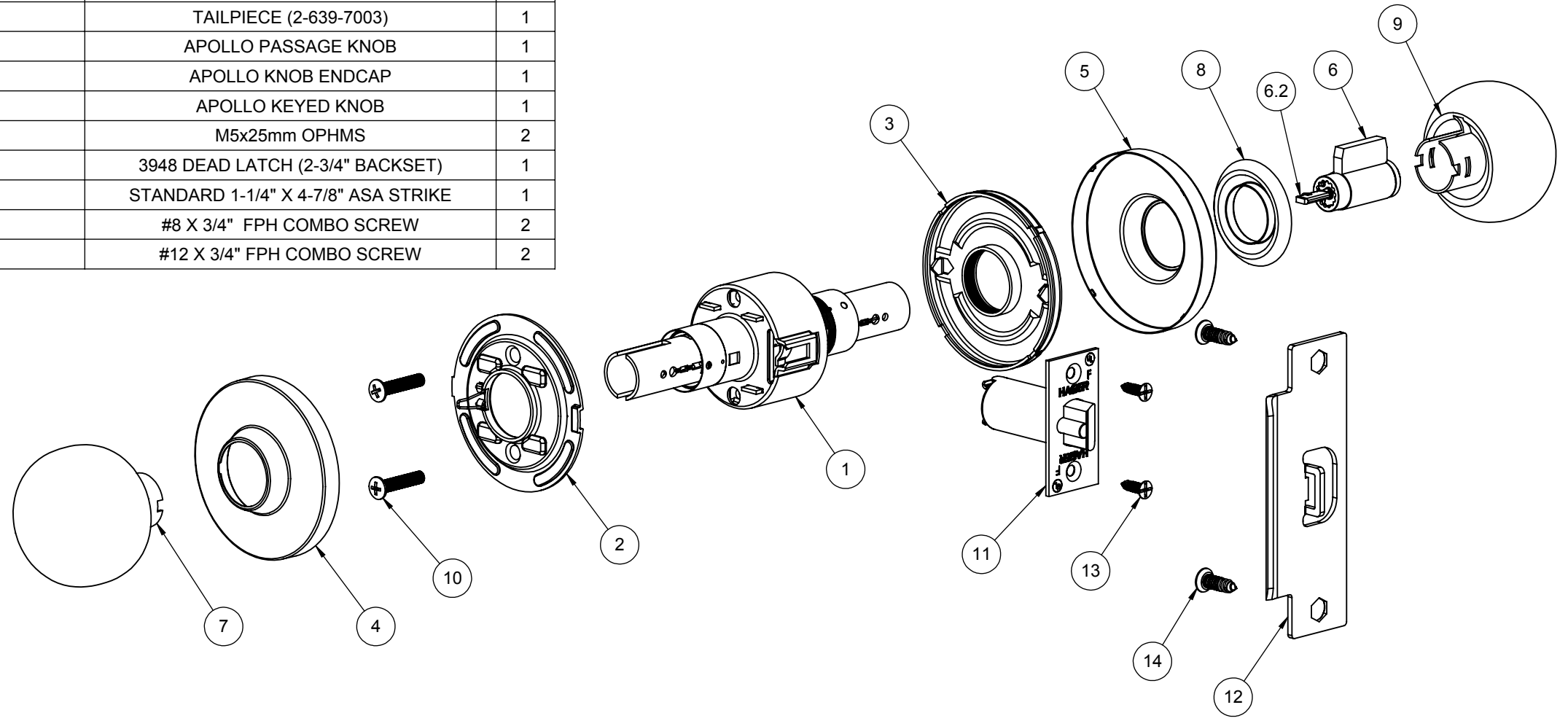

ITEM NO.	FILE NUMBER	DESCRIPTION	QTY.
1	S-LS00960	KNOBSET CHASSIS - 70 FUNCTION	1
2	S-LS00966	INSIDE ROSE LINER	1
3	S-LS00962	OUTSIDE ROSE LINER	1
4	S-LS00952	INSIDE ROSE (KNOB)	1
5	S-LS00952	OUTSIDE ROSE (KNOB)	1
6	S-LS00617	6 PIN DRILLED CYLINDER	1
6.2	S-LS00215	TAILPIECE (2-639-7003)	1
7	S-LS00953	APOLLO PASSAGE KNOB	1
8	S-LS00954	APOLLO KNOB ENDCAP	1
9	S-LS00953	APOLLO KEYED KNOB	1
10	Oval Head_AM	M5x25mm OPHMS	2
11	S-LS00306	3948 DEAD LATCH (2-3/4" BACKSET)	1
12	S-LS00236	STANDARD 1-1/4" X 4-7/8" ASA STRIKE	1
13	S-LS00882	#8 X 3/4" FPH COMBO SCREW	2
14	S-LS00882	#12 X 3/4" FPH COMBO SCREW	2



NOTE: (2) KEYS PROVIDED

 PROPRIETARY & CONFIDENTIAL THE INFORMATION CONTAINED IN THIS DRAWING IS THE SOLE PROPERTY OF HAGER COMPANIES. ANY REPRODUCTION IN PART OR AS A WHOLE WITHOUT THE WRITTEN PERMISSION OF HAGER COMPANIES IS PROHIBITED.	HAGER RESERVES THE RIGHT TO MAKE DESIGN CHANGES WITHOUT NOTICE. CALL HAGER ENGINEERING AT 1-800-325-9995 FOR THE LATEST REVISION DATE OF TEMPLATE.	MATERIAL	Material <not specified>	DRAWN	MRJ	11/22/2010	3570 GRADE 2 - CLASSROOM KNOBSET			
		FINISH	-	ENG. APPR.	-	-			Q.A.	
		DO NOT SCALE DRAWING			TOLERANCES: FRACTIONAL: ±0.015" ANGULAR: MACH: ±1° BEND: ±1° TWO PLACE DECIMAL: ±0.01" THREE PLACE DECIMAL: ±0.004"			SIZE	DWG. NO.	REV.
								B	S-LS01053	01
						SCALE:1:4	WEIGHT: 1.31	SHEET 1 OF 1		