



3400 Series Knob

Description: Cylindrical Locks - Grade 1 > 3400 Series Knob



<p>Applications</p> <ul style="list-style-type: none"> - Extra Heavy-Duty Commercial - Industrial - Institutional - Standard Door Prep - 2 1/8" Diameter (Cross Bore) - Latch Hole - 1" Diameter (Edge Bore) <p>Certifications</p> <ul style="list-style-type: none"> - BHMA Certified ANSI A156.2, Series 4000, Grade 1 - ANSI A250.13 Severe Windstorm Resistant Component - UL/cUL Listed for all functions up to 3 hours for "A" label single doors - UL10C/UBC 7-2 (1997) Positive Pressure Rated - UL10B Neutral Pressure Rated <p>Knob Diameter</p> <ul style="list-style-type: none"> - 2-9/32" (58 mm) <p>Rose Diameter</p> <ul style="list-style-type: none"> - 3" (76 mm) <p>Exposed Trim</p> <ul style="list-style-type: none"> - Wrought Brass or Stainless Steel <p>Lock Chassis</p> <ul style="list-style-type: none"> - Heavy gauge steel, zinc dichromated for corrosion resistance <p>Keys</p> <ul style="list-style-type: none"> - Two brass keys per lock <p>Cylinders</p> <ul style="list-style-type: none"> - Brass 6-pin - Keyed Different - C Keyway - Other keying options available from factory 	<p>Door Thickness</p> <ul style="list-style-type: none"> - 1 3/8" - 1 3/4" <p>Backset</p> <ul style="list-style-type: none"> - 2 3/4" - 2 3/8" Optional <p>Latchbolt</p> <ul style="list-style-type: none"> - 1/2" Throw - Stainless Steel - 2 1/4" x 1 1/8" Faceplate - Deadlocking latchbolt prevents manipulation when door is closed; keyed functions only <p>Strikes</p> <ul style="list-style-type: none"> - ANSI 4-7/8" x 1-1/4" strike - standard - Optional strikes available <p>Functions</p> <ul style="list-style-type: none"> - 53 Entry - 70 Classroom - 80 Storeroom - 40 Privacy - 10 Passage - 17 Dummy <p>Finishes</p> <ul style="list-style-type: none"> - US3, US32D
---	---

ITEM NO.	FILE NUMBER	DESCRIPTION	QTY.
1	S-LS00950	KNOBSET CHASSIS - 10 FUNCTION	1
2	S-LS00956	OUTSIDE ROSE LINER (KNOB)	1
3	S-LS00955	INSIDE ROSE LINER (KNOB)	1
4	S-LS00953	APOLLO PASSAGE KNOB	2
5	S-LS00952	OUTSIDE ROSE (KNOB)	1
6	S-LS00951	INSIDE ROSE (KNOB)	1
7	S-LS00943	THREADED COLLAR	1
8	S-LS00236	STANDARD 1-1/4" X 4-7/8" ASA STRIKE	1
9	S-LS00618	3943 SPRING LATCH (2-3/4" BACKSET)	1
10	S-LS00882	#8 X 3/4" FPH COMBO SCREW	2
11	S-LS00882	#12 X 3/4" FPH COMBO SCREW	2

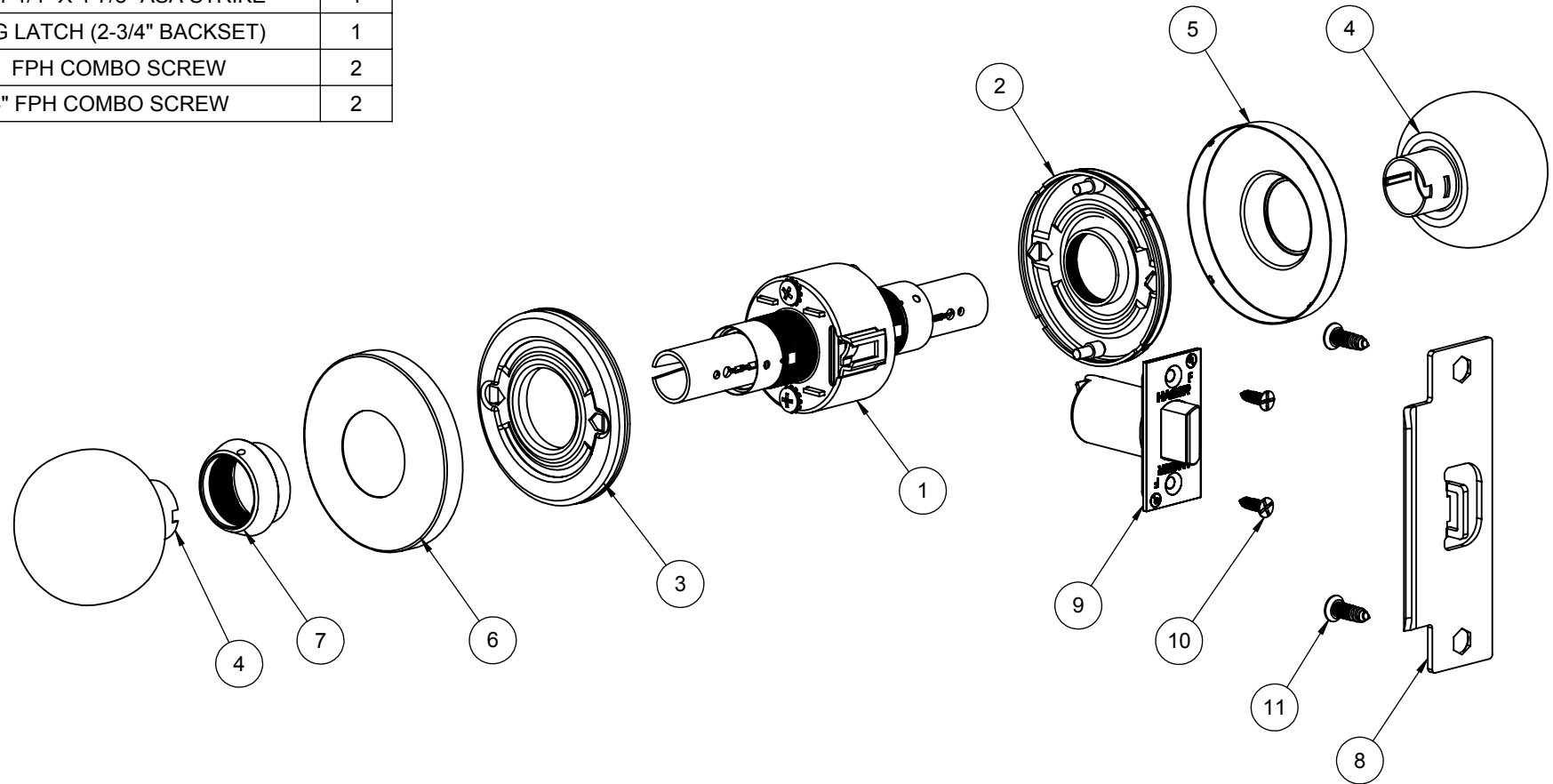

 <p>PROPRIETARY & CONFIDENTIAL THE INFORMATION CONTAINED IN THIS DRAWING IS THE SOLE PROPERTY OF HAGER COMPANIES. ANY REPRODUCTION IN PART OR AS A WHOLE WITHOUT THE WRITTEN PERMISSION OF HAGER COMPANIES IS PROHIBITED.</p>	<p>HAGER RESERVES THE RIGHT TO MAKE DESIGN CHANGES WITHOUT NOTICE. CALL HAGER ENGINEERING AT 1-800-325-9995 FOR THE LATEST REVISION DATE OF TEMPLATE.</p>	<p>DRAWN MRJ 11/18/2010</p>	<p>3410 GRADE 1 - PASSAGE KNOBSET</p>		
		<p>ENG. APPR. - -</p>			
		<p>MATERIAL Material <not specified></p>	<p>Q.A.</p>	<p>SIZE DWG. NO. B S-LS01043</p>	<p>REV. 01</p>
		<p>FINISH -</p>	<p>DO NOT SCALE DRAWING</p>	<p>TOLERANCES: FRACTIONAL: ±0.015" ANGULAR: MACH: ±1° BEND: ±1° TWO PLACE DECIMAL: ±0.01" THREE PLACE DECIMAL: ±0.004"</p>	<p>SCALE: 1:4 WEIGHT: 1.15 SHEET 1 OF 1</p>

ITEM NO.	FILE NUMBER	DESCRIPTION	QTY.
1	S-LS00952	OUTSIDE ROSE (KNOB)	1
2	S-LS00444	KNOB DUMMY MOUNTING PLATE	1
3	S-LS00448	FINISH WASHER	1
4	Flat Head 100 Screw_AI	1/4 - 20 x 2" FPHMS	1
5	S-LS01058	DUMMY KNOB ASSEMBLY	1

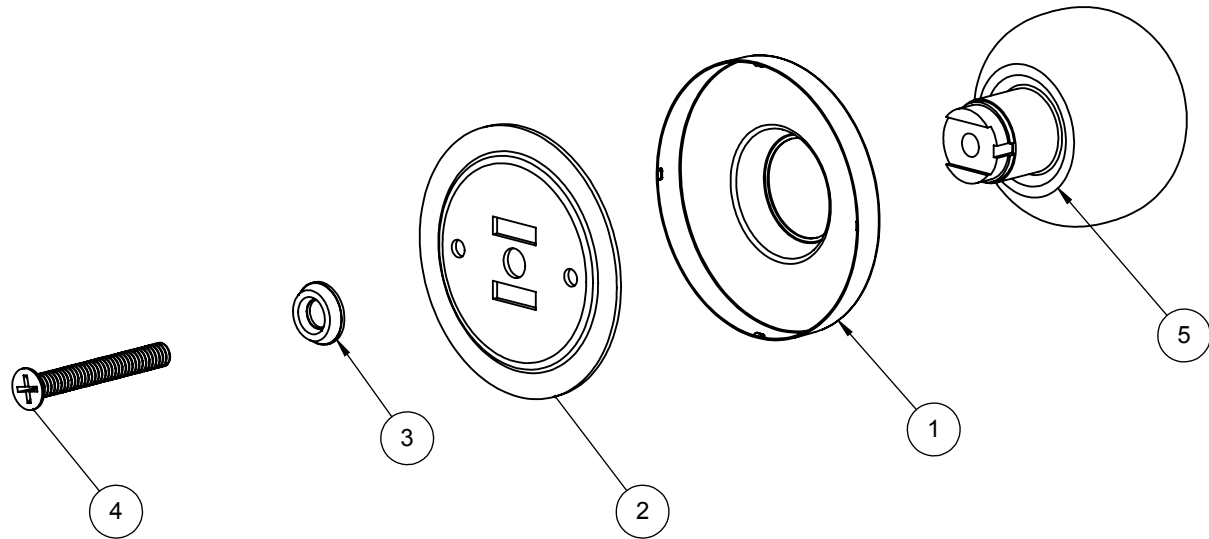

 PROPRIETARY & CONFIDENTIAL THE INFORMATION CONTAINED IN THIS DRAWING IS THE SOLE PROPERTY OF HAGER COMPANIES. ANY REPRODUCTION IN PART OR AS A WHOLE WITHOUT THE WRITTEN PERMISSION OF HAGER COMPANIES IS PROHIBITED.	HAGER RESERVES THE RIGHT TO MAKE DESIGN CHANGES WITHOUT NOTICE. CALL HAGER ENGINEERING AT 1-800-325-9995 FOR THE LATEST REVISION DATE OF TEMPLATE.	DRAWN MRJ 11/23/2010	3417 GRADE 1 - DUMMY KNOBSET			
		ENG. APPR. - -	Q.A.			
		MATERIAL Material <not specified>	TOLERANCES: FRACTIONAL: ±0.015" ANGULAR: MACH: ± 1° BEND: ±1° TWO PLACE DECIMAL: ±0.01" THREE PLACE DECIMAL: ±0.004"		SIZE A	DWG. NO. S-LS01059
		FINISH -	DO NOT SCALE DRAWING		REV. -	
		SCALE: 1:4	WEIGHT: 0.06	SHEET 1 OF 1		

ITEM NO.	FILE NUMBER	DESCRIPTION	QTY.
1	S-LS00950	KNOBSET CHASSIS - 40 FUNCTION	1
2	S-LS00956	OUTSIDE ROSE LINER (KNOB)	1
3	S-LS00955	INSIDE ROSE LINER (KNOB)	1
4	S-LS00953	APOLLO PUSHBUTTON KNOB	2
5	S-LS00952	OUTSIDE ROSE (KNOB)	1
6	S-LS00951	INSIDE ROSE (KNOB)	1
7	S-LS00943	THREADED COLLAR	1
8	S-LS00236	STANDARD 1-1/4" X 4-7/8" ASA STRIKE	1
9	S-LS00618	3964 SPRING LATCH (2-3/4" BACKSET)	1
10	S-LS00882	#8 X 3/4" FPH COMBO SCREW	2
11	S-LS00882	#12 X 3/4" FPH COMBO SCREW	2
12	S-LS01042	COINTURN BUTTON ASSEMBLY	1

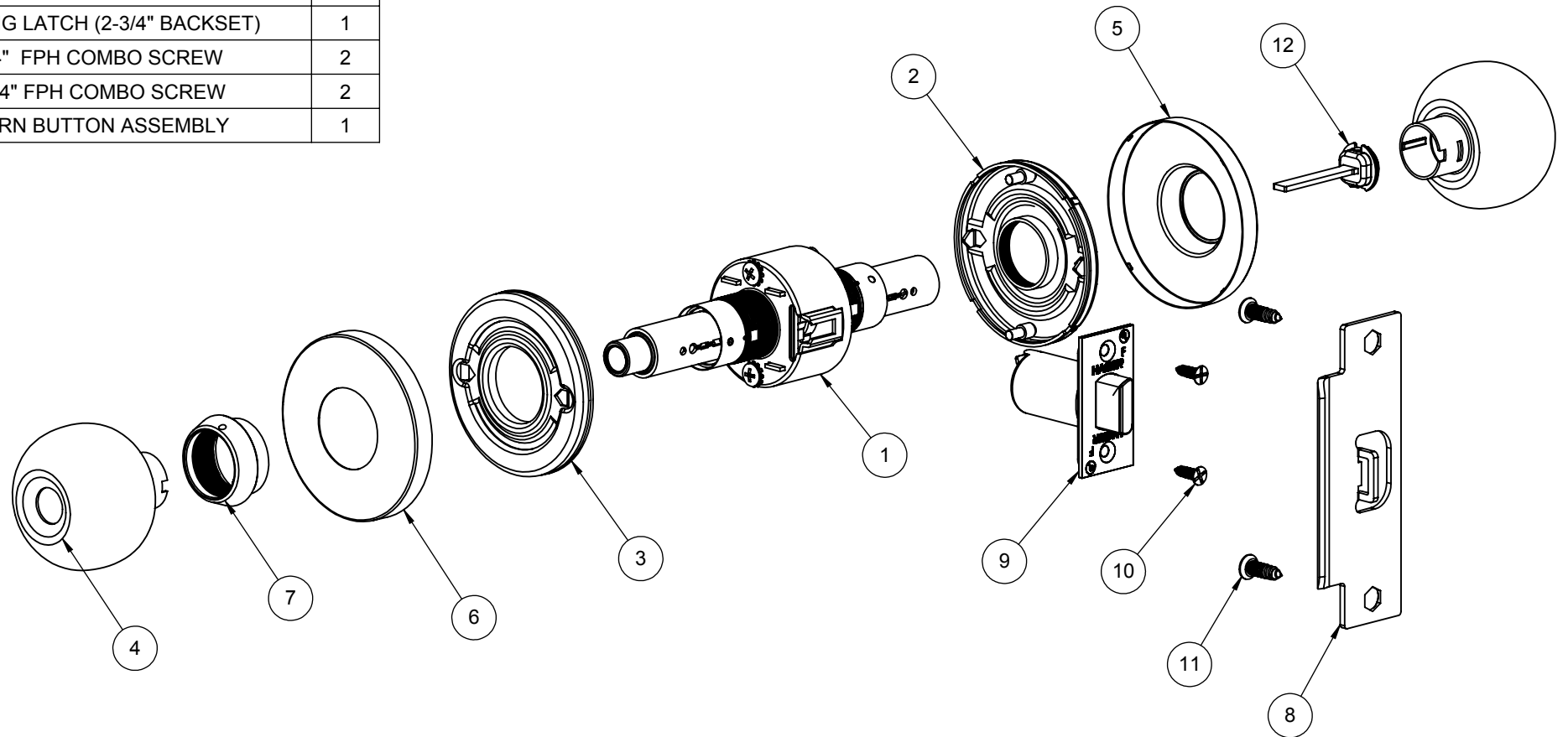

 PROPRIETARY & CONFIDENTIAL THE INFORMATION CONTAINED IN THIS DRAWING IS THE SOLE PROPERTY OF HAGER COMPANIES. ANY REPRODUCTION IN PART OR AS A WHOLE WITHOUT THE WRITTEN PERMISSION OF HAGER COMPANIES IS PROHIBITED.	HAGER RESERVES THE RIGHT TO MAKE DESIGN CHANGES WITHOUT NOTICE. CALL HAGER ENGINEERING AT 1-800-325-9995 FOR THE LATEST REVISION DATE OF TEMPLATE.	DRAWN	MRJ	11/18/2010	3440 GRADE 1 - PRIVACY KNOBSET		
		ENG. APPR.	-	-			
		MATERIAL	Material <not specified>			Q.A.	
		FINISH	-			TOLERANCES: FRACTIONAL: ± 0.015 " ANGULAR: MACH: $\pm 1^\circ$ BEND: $\pm 1^\circ$ TWO PLACE DECIMAL: ± 0.01 " THREE PLACE DECIMAL: ± 0.004 "	
DO NOT SCALE DRAWING		SIZE	DWG. NO.		REV.		
		B	S-LS01044		01		
		SCALE: 1:4	WEIGHT: 1.26		SHEET 1 OF 1		

ITEM NO.	FILE NUMBER	DESCRIPTION	QTY.
1	S-LS00950	KNOBSET CHASSIS - 53 FUNCTION	1
2	S-LS00956	OUTSIDE ROSE LINER (KNOB)	1
3	S-LS00955	INSIDE ROSE LINER (KNOB)	1
4	S-LS00954	APOLLO KNOB ENDCAP	1
5	S-LS00953	APOLLO KEYED KNOB	1
6	S-LS00952	OUTSIDE ROSE (KNOB)	1
7	S-LS00951	INSIDE ROSE (KNOB)	1
8	S-LS00953	APOLLO PUSHBUTTON KNOB	1
9	S-LS00943	THREADED COLLAR	1
10	S-LS00617	6-PIN DRILLED CYLINDER	1
10.2	S-LS00214	TAILPIECE (2-639-7002)	1
11	S-LS00236	STANDARD 1-1/4" X 4-7/8" ASA STRIKE	1
12	S-LS00882	#8 X 3/4" FPH COMBO SCREW	2
13	S-LS00882	#12 X 3/4" FPH COMBO SCREW	2
14	S-LS00608	3944 DEAD LATCH (2-3/4" BACKSET)	1

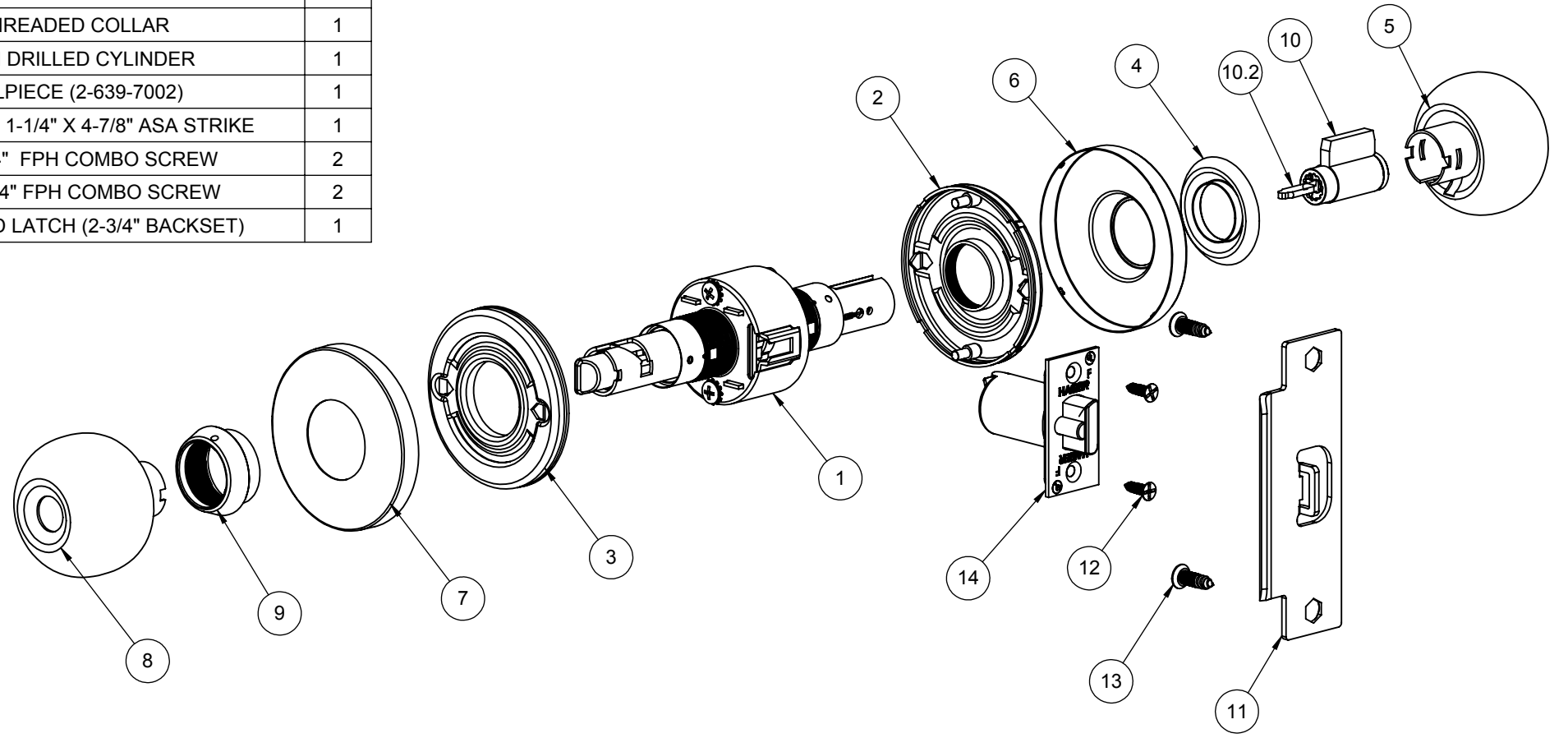

NOTE: (2) KEYS PROVIDED

 PROPRIETARY & CONFIDENTIAL THE INFORMATION CONTAINED IN THIS DRAWING IS THE SOLE PROPERTY OF HAGER COMPANIES. ANY REPRODUCTION IN PART OR AS A WHOLE WITHOUT THE WRITTEN PERMISSION OF HAGER COMPANIES IS PROHIBITED.	HAGER RESERVES THE RIGHT TO MAKE DESIGN CHANGES WITHOUT NOTICE. CALL HAGER ENGINEERING AT 1-800-325-9995 FOR THE LATEST REVISION DATE OF TEMPLATE.	MATERIAL	Material <not specified>	DRAWN	MRJ	11/18/2010	3453 GRADE 1 - ENTRY KNOBSET			
		FINISH	-	ENG. APPR.	-	-			Q.A.	
		DO NOT SCALE DRAWING			TOLERANCES: FRACTIONAL: ±0.015" ANGULAR: MACH: ±1° BEND: ±1° TWO PLACE DECIMAL: ±0.01" THREE PLACE DECIMAL: ±0.004"			SIZE	DWG. NO.	REV.
								B	S-LS01045	02
						SCALE: 1:4	WEIGHT: 1.38	SHEET 1 OF 1		

ITEM NO.	FILE NUMBER	DESCRIPTION	QTY.
1	S-LS00950	KNOBSET CHASSIS - 53 FUNCTION - IC	1
2	S-LS00956	OUTSIDE ROSE LINER (KNOB)	1
3	S-LS00955	INSIDE ROSE LINER (KNOB)	1
4	S-LS00952	OUTSIDE ROSE (KNOB)	1
5	S-LS00951	INSIDE ROSE (KNOB)	1
6	S-LS00953	APOLLO PUSHBUTTON KNOB	1
7	S-LS00943	THREADED COLLAR	1
8	S-LS00550	INTERCHANGEABLE CORE	1
9	S-LS00225	IC TAILPIECE	1
10	S-LS00236	STANDARD 1-1/4" X 4-7/8" ASA STRIKE	1
11	S-LS00882	#8 X 3/4" FPH COMBO SCREW	2
12	S-LS00882	#12 X 3/4" FPH COMBO SCREW	2
13	S-LS00608	3944 DEAD LATCH (2-3/4" BACKSET)	1
14	S-LS01055	APOLLO KNOB ASSEMBLY - IC	1

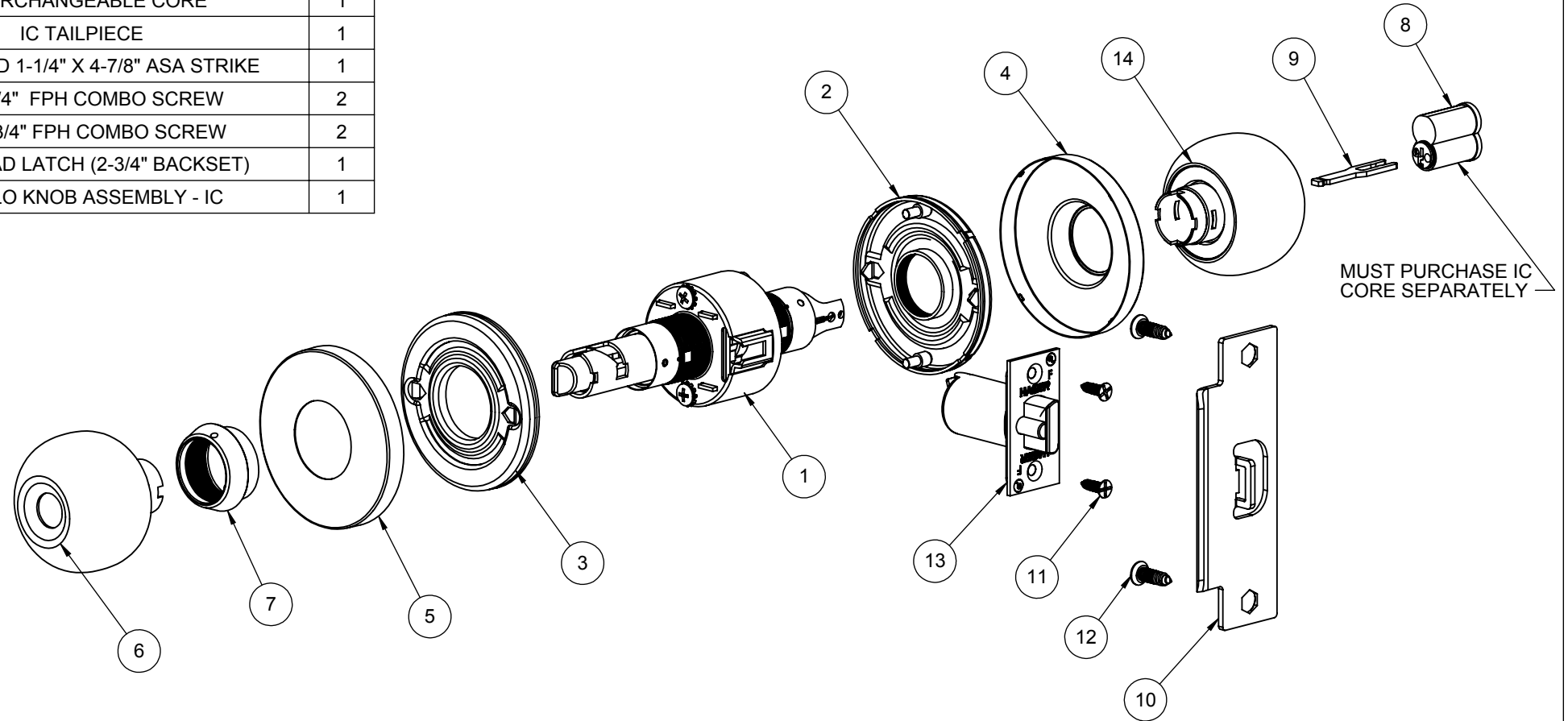

PROPRIETARY & CONFIDENTIAL
 THE INFORMATION CONTAINED IN THIS DRAWING IS THE SOLE PROPERTY OF HAGER COMPANIES. ANY REPRODUCTION IN PART OR AS A WHOLE WITHOUT THE WRITTEN PERMISSION OF HAGER COMPANIES IS PROHIBITED.

HAGER RESERVES THE RIGHT TO MAKE DESIGN CHANGES WITHOUT NOTICE. CALL HAGER ENGINEERING AT 1-800-325-9995 FOR THE LATEST REVISION DATE OF TEMPLATE.

MATERIAL	Material <not specified>
FINISH	-
DO NOT SCALE DRAWING	

DRAWN	MRJ	11/18/2010
ENG. APPR.	-	-
TOLERANCES:		
FRACTIONAL: ±0.015"		
ANGULAR: MACH: ±1° BEND: ±1°		
TWO PLACE DECIMAL: ±0.01"		
THREE PLACE DECIMAL: ±0.004"		

3453		GRADE 1 - ENTRY KNOBSET - IC	
SIZE	DWG. NO.	REV.	
B	S-LS01046	02	
SCALE: 1:4	WEIGHT: 1.43	SHEET 1 OF 1	

ITEM NO.	FILE NUMBER	DESCRIPTION	QTY.
1	S-LS00950	KNOBSET CHASSIS - 70 FUNCTION - IC	1
2	S-LS00956	OUTSIDE ROSE LINER (KNOB)	1
3	S-LS00955	INSIDE ROSE LINER (KNOB)	1
4	S-LS00954	APOLLO KNOB ENDCAP	1
5	S-LS00953	APOLLO KEYED KNOB	1
6	S-LS00952	OUTSIDE ROSE (KNOB)	1
7	S-LS00951	INSIDE ROSE (KNOB)	1
8	S-LS00953	APOLLO PASSAGE KNOB	1
9	S-LS00943	THREADED COLLAR	1
10	S-LS00617	6-PIN DRILLED CYLINDER	1
10.2	S-LS00215	TAILPIECE (2-639-7003)	1
11	S-LS00236	STANDARD 1-1/4" X 4-7/8" ASA STRIKE	1
12	S-LS00882	#8 X 3/4" FPH COMBO SCREW	2
13	S-LS00882	#12 X 3/4" FPH COMBO SCREW	2
14	S-LS00608	3944 DEAD LATCH (2-3/4" BACKSET)	1

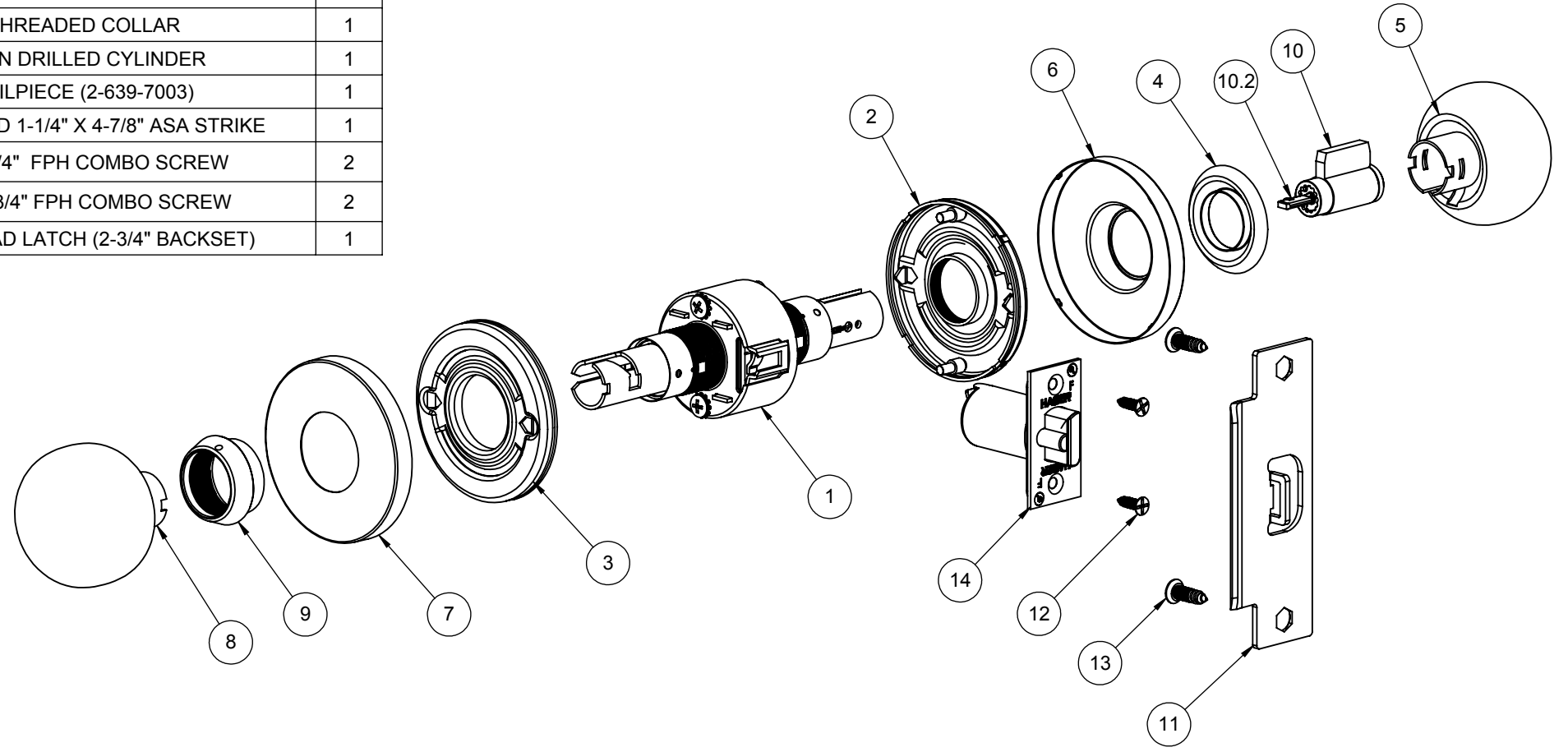

NOTE: (2) KEYS PROVIDED

 <p>PROPRIETARY & CONFIDENTIAL THE INFORMATION CONTAINED IN THIS DRAWING IS THE SOLE PROPERTY OF HAGER COMPANIES. ANY REPRODUCTION IN PART OR AS A WHOLE WITHOUT THE WRITTEN PERMISSION OF HAGER COMPANIES IS PROHIBITED.</p>	<p>HAGER RESERVES THE RIGHT TO MAKE DESIGN CHANGES WITHOUT NOTICE. CALL HAGER ENGINEERING AT 1-800-325-9995 FOR THE LATEST REVISION DATE OF TEMPLATE.</p>	DRAWN	MRJ	11/18/2010	<p>3470 GRADE 1 - CLASSROOM KNOBSET</p>		
		ENG. APPR.	-	-			
		MATERIAL	Material <not specified>			Q.A.	
		FINISH	-			<p>TOLERANCES: FRACTIONAL: ±0.015" ANGULAR: MACH: ±1° BEND: ±1° TWO PLACE DECIMAL: ±0.01" THREE PLACE DECIMAL: ±0.004"</p>	
DO NOT SCALE DRAWING		SIZE DWG. NO.		REV.			
		B		S-LS01047			
		SCALE: 1:4		WEIGHT: 1.41			
				SHEET 1 OF 1			

ITEM NO.	FILE NUMBER	DESCRIPTION	QTY.
1	S-LS00950	KNOBSET CHASSIS - 80 FUNCTION	1
2	S-LS00956	OUTSIDE ROSE LINER (KNOB)	1
3	S-LS00955	INSIDE ROSE LINER (KNOB)	1
4	S-LS00954	APOLLO KNOB ENDCAP	1
5	S-LS00952	OUTSIDE ROSE (KNOB)	1
6	S-LS00951	INSIDE ROSE (KNOB)	1
7	S-LS00953	APOLLO PASSAGE KNOB	1
8	S-LS00943	THREADED COLLAR	1
9	S-LS00617	6-PIN DRILLED CYLINDER	1
9.2	S-LS00214	TAILPIECE (2-639-7002)	1
10	S-LS00236	STANDARD 1-1/4" X 4-7/8" ASA STRIKE	1
11	S-LS00882	#8 X 3/4" FPH COMBO SCREW	2
12	S-LS00882	#12 X 3/4" FPH COMBO SCREW	2
13	S-LS00608	3944 DEAD LATCH (2-3/4" BACKSET)	1
14	S-LS00953	APOLLO KEYED KNOB	1

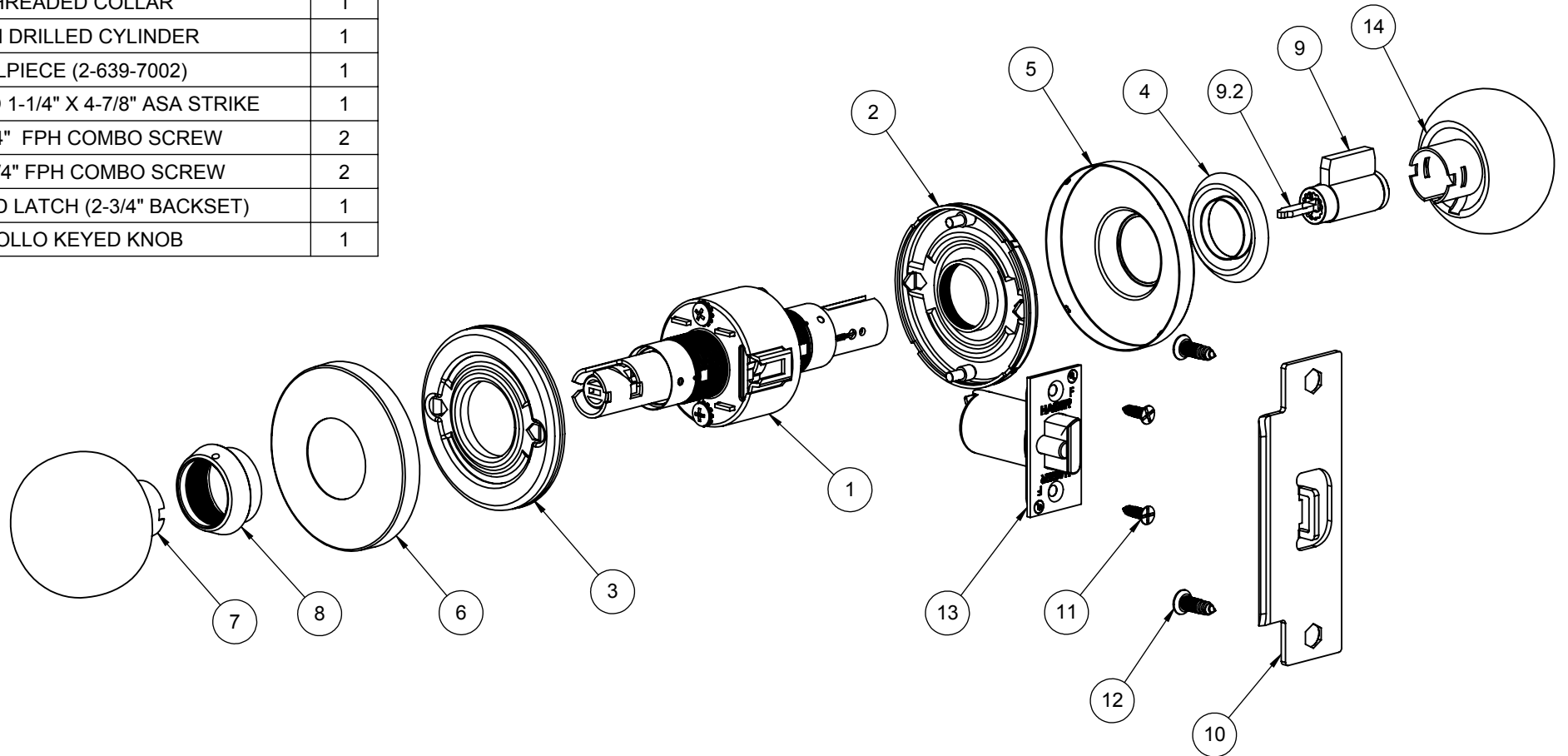

NOTE: (2) KEYS PROVIDED



PROPRIETARY & CONFIDENTIAL
 THE INFORMATION CONTAINED
 IN THIS DRAWING IS THE SOLE
 PROPERTY OF HAGER
 COMPANIES. ANY REPRODUCTION
 IN PART OR AS A WHOLE WITHOUT
 THE WRITTEN PERMISSION OF
 HAGER COMPANIES IS PROHIBITED.

HAGER RESERVES
 THE RIGHT TO
 MAKE DESIGN
 CHANGES
 WITHOUT NOTICE.
 CALL HAGER
 ENGINEERING AT
 1-800-325-9995
 FOR THE LATEST
 REVISION DATE
 OF TEMPLATE.

MATERIAL	Material <not specified>
FINISH	-
DO NOT SCALE DRAWING	

DRAWN	MRJ	11/18/2010
ENG. APPR.	-	-
TOLERANCES:		
FRACTIONAL: ±0.015"		
ANGULAR: MACH: ±1° BEND: ±1°		
TWO PLACE DECIMAL: ±0.01"		
THREE PLACE DECIMAL: ±0.004"		

3480		GRADE 1 - STOREROOM KNOBSET	
SIZE	DWG. NO.	REV.	
B	S-LS01048	02	
SCALE: 1:4	WEIGHT: 1.38	SHEET 1 OF 1	



HAGER LOCKSET KNOB AND LEVER OPTIONS



APOLLO KNOB

Available on:

- 3400 Series
- 3500 Series

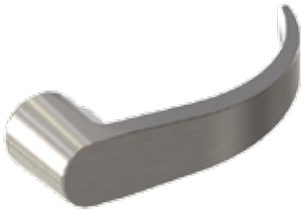

ARCHER LEVER

Available on:

- 3400 Series
- 3400 Series (Electrified)
- 3500 Series
- 3600 Series
- 3700 Series
- 3800 Series - Escutcheon
- 3800 Series - Sectional
- 3800 Series - Escutcheon (Electrified)
- 3800 Series - Sectional (Electrified)
- 2500 Series



AUGUST LEVER

Available on:

- 3400 Series
- 3400 Series (Electrified)
- 3500 Series
- 3600 Series
- 3700 Series
- 3800 Series - Escutcheon
- 3800 Series - Sectional
- 3800 Series - Escutcheon (Electrified)
- 3800 Series - Sectional (Electrified)



WILLIAM LEVER

Available on:

- 3800 Series - Escutcheon
- 3800 Series - Sectional
- 3800 Series - Escutcheon (Electrified)
- 3800 Series - Sectional (Electrified)



WITHNELL LEVER

Available on:

- 3400 Series
- 3400 Series (Electrified)
- 3500 Series
- 3600 Series
- 3700 Series
- 3800 Series - Escutcheon
- 3800 Series - Sectional
- 3800 Series - Escutcheon (Electrified)
- 3800 Series - Sectional (Electrified)
- 2500 Series





Hager Companies, Inc
139 Victor Street
Saint Louis, MO 63104

HAGER TEST REPORT NO.: LS04013

EVALUATION OF

**Hager Companies
3400 Series Grade 1 Knob Lockset**

TEST PARAMETERS:

This report covers tests and/or evaluations performed using the following standard(s) as a guideline:
ANSI/BHMA A156.2-2003 American National Standard for Bored and Preamsembled Locks & Latches.
Testing was conducted by Intertek Testing Services NA, Inc., at their Middleton, WI facility.

DESCRIPTION OF TEST SAMPLES:

Samples were identified as Model 3400 Grade 1 Cylindrical Knob Lockset.
Samples were received in good condition on 06/01/2004.

TEST DATES: 6/04/2004 – 6/29/2004

RESULTS: COMPLIANT

The testing results of specific subsections are summarized below.

Subsection	Test Description	Test Results
9	Operational Tests	Compliant
10	Strength Tests	Compliant
11	Cycle Tests	Compliant
12	Performance after Cycle Tests	Compliant
13	Material Evaluation Tests	Compliant

This report summary was prepared as an account of work performed by a Third-Party Nationally Recognized Testing Laboratory. The information included in this report is certified extracts from the original test records, as contained in the permanent records of Hager Companies, Inc. Copies of the original third-party test reports are available upon request.



3400 SERIES LOCKS HOW TO ORDER

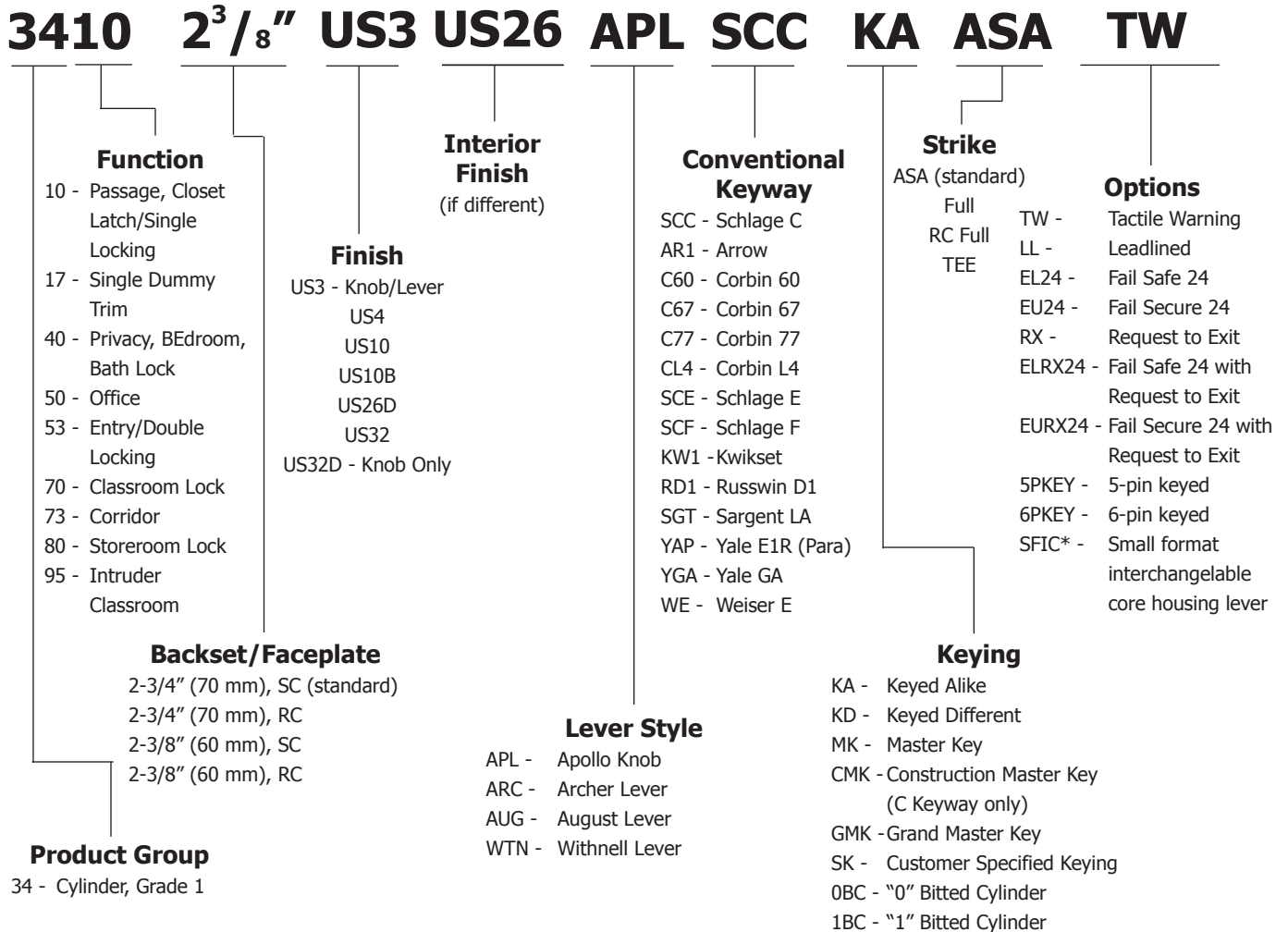

Notes:

1. If master-keyed, include master key instruction sheet with order (available in catalog or online).

* Small format interchangeable core sold separately. Available in Best Keyways only, A Standard.

Ordering example: 3453 2-3/4" SC US26D WTN NC ASA SFIC





The following products have been approved for statewide acceptance by the Florida Building Commission pursuant to Rule 9B-72.090, F.A.C., for approval of products and systems for use on Exterior Swinging Door Assemblies, in compliance with the structural requirements of the 2007 Florida Building Code. Verification of Florida Statewide acceptance can be found at www.floridabuilding.org under the Product Approval section.

**Severe Windstorm Resistant Components for Swinging Door Assemblies
ANSI A250.13 - 2003 Standard**

Certified Hardware	Assembly Configuration	Door Size	Door Stiffness Class	Design Load	Florida Certification Number (FL#)
3100 Series Grade 1 Deadbolt	Single - Out Swing	3-0 x 7-0	-	1150 lbf (100 psf)*	6118
	Single - Out Swing	4-0 x 8-0	-	1150 lbf (70 psf)*	
3200 Series Grade 2 Deadbolt	Single - Out Swing	3-0 x 7-0	-	1150 lbf (100 psf)*	6118
	Single - Out Swing	4-0 x 8-0	-	1150 lbf (70 psf)*	
3400 Series Grade 1 Lockset	Single - Out Swing	3-0 x 7-0	-	1150 lbf (100 psf)*	6118
	Single - Out Swing	4-0 x 8-0	-	1150 lbf (70 psf)*	
3500 Series Grade 2 Lockset	Single - Out Swing	3-0 x 7-0	-	860 lbf (80 psf)*	7683
	Single - Out Swing	4-0 x 8-0	-	860 lbf (50 psf)*	
3800 Series Grade 1 Mortise	Single - Out Swing	3-0 x 7-0	-	1150 lbf (100 psf)*	12932
	Single - Out Swing	4-0 x 8-0	-	1150 lbf (70 psf)*	
4500 Rim Exit Device	Single - Out Swing	4-0 x 8-0 max.	I	+/- 70 psf 350 ft-lbs Impact	9481
4500 SVR Exit Device	Out Swing	8-0 x 8-0 pair max.	I	+/- 50 psf 350 ft-lbs Impact	13178
4700 Rim Exit Device	Single - Out Swing	4-0 x 8-0 max.	I	+/- 40 psf 350 ft-lbs Impact	8293
780-112 Roton Hinge	Single Swing	4-0 x 8-0 max.	I	1150 lbf (72 psf)* 350 ft-lbs Impact	6118
BB1191 Hinge	Single - Out Swing	-	-	1780 lbf**	6118

* Load in parenthesis indicates the equivalent load in pounds per square foot based on indicated door size and door stiffness (if applicable). This load is based on the hardware item taking half of the force applied to the door assembly by the wind load and the hinges taking the other half.

** This load indicates the design load for a single butt hinge. Maximum wind load should be calculated based on door size, number of hinges used, and the other available door hardware on the door assembly.