

2517 DUMMY INSTRUCTIONS DIRECT DOOR MOUNTING

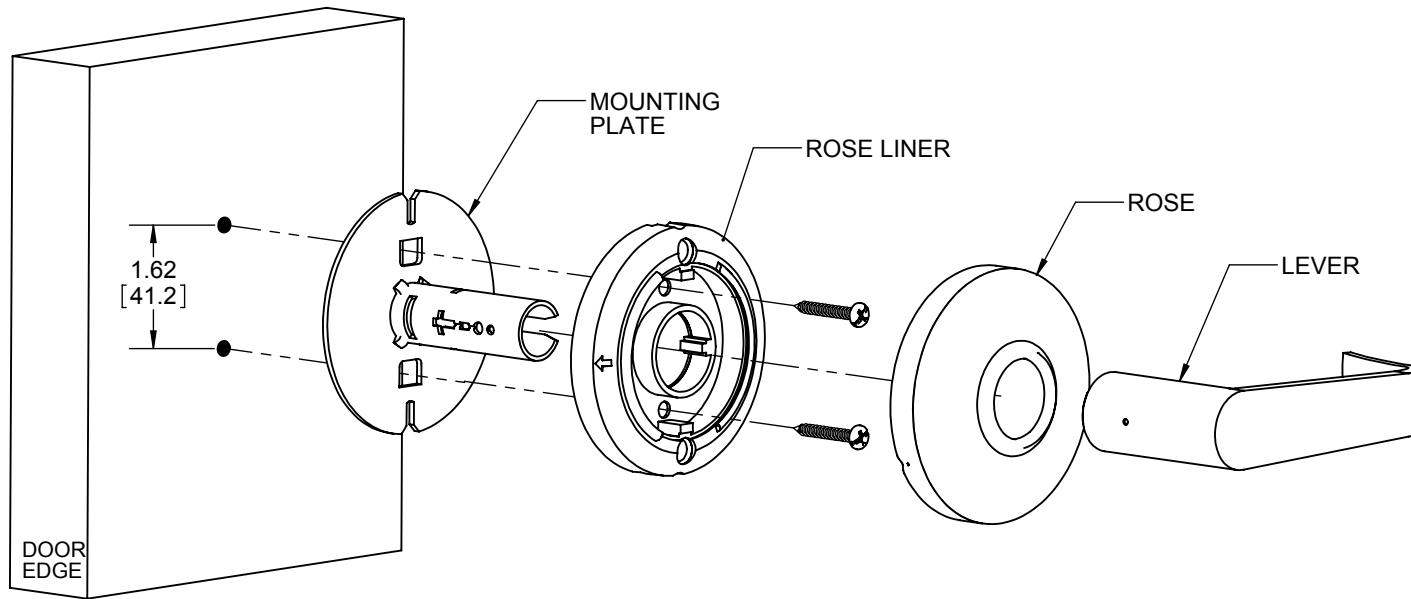

1. **WOOD DOOR** - DRILL (2) 1/8"[3.2] DIAMETER PILOT HOLES 1" [25.4] DEEP IN THE FACE OF THE DOOR.
METAL DOOR - DRILL (2) 11/64"[4.4] DIAMETER PILOT HOLES INTO THE FACE OF THE DOOR. TAP HOLES USING 8-32 TAP.
2. INSERT MOUNTING PLATE THROUGH ROSE LINER SO THEY SIT FLUSH.
3. **WOOD DOOR** - SCREW (2) #8 X 1-1/8" WOOD SCREWS INTO THE DOOR TO SECURE THE ROSE LINER AND MOUNTING PLATE.
METAL DOOR - SCREW (2) 8-32 x 1" MACHINE SCREWS INTO THE DOOR TO SECURE ROSE LINER AND MOUNTING PLATE.
4. INSTALL ROSE OVER ROSE LINER.
5. INSERT LEVER UNTIL IT SNAPS SECURELY IN PLACE.

DIMENSIONS IN [] ARE IN MILLIMETERS