

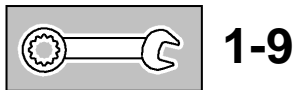

35 601

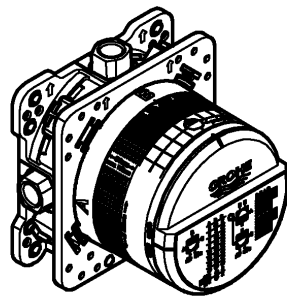

Grohtherm SmartControl

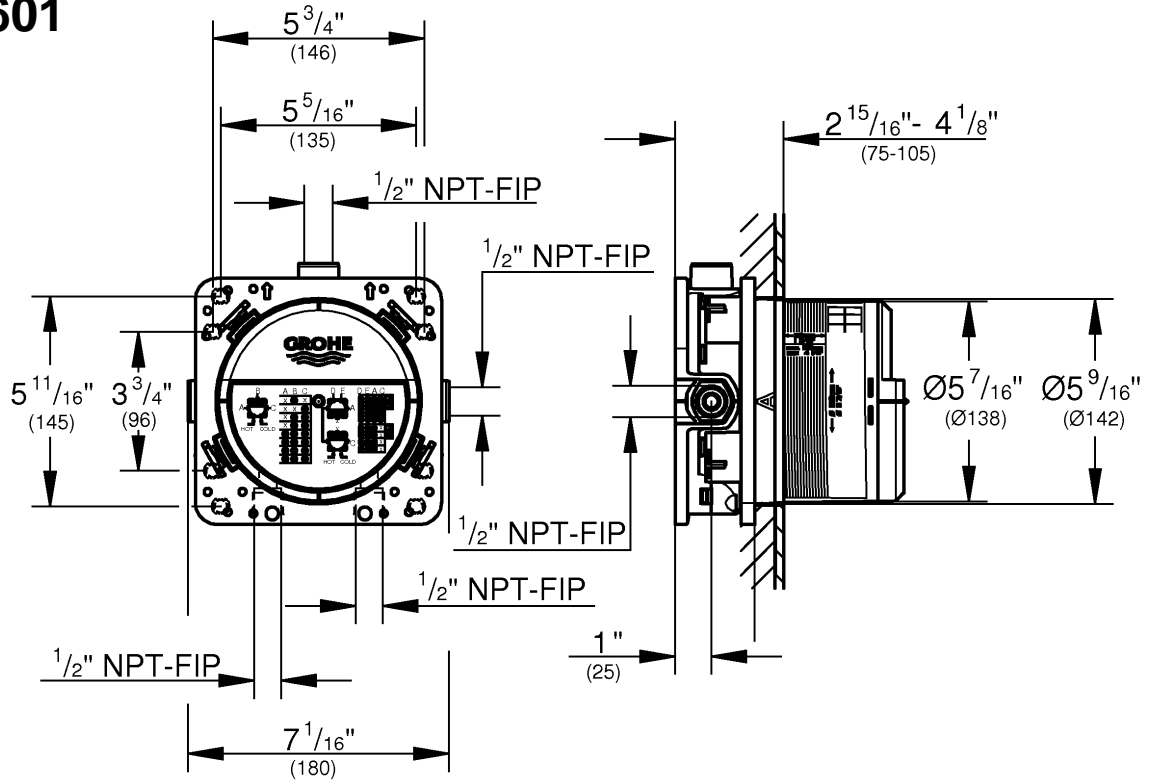
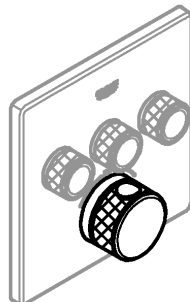

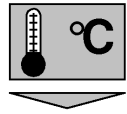
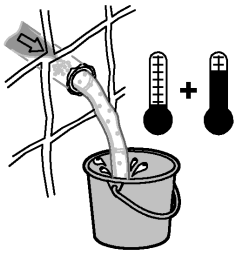

max.
70 °

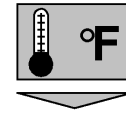

max.
158 °

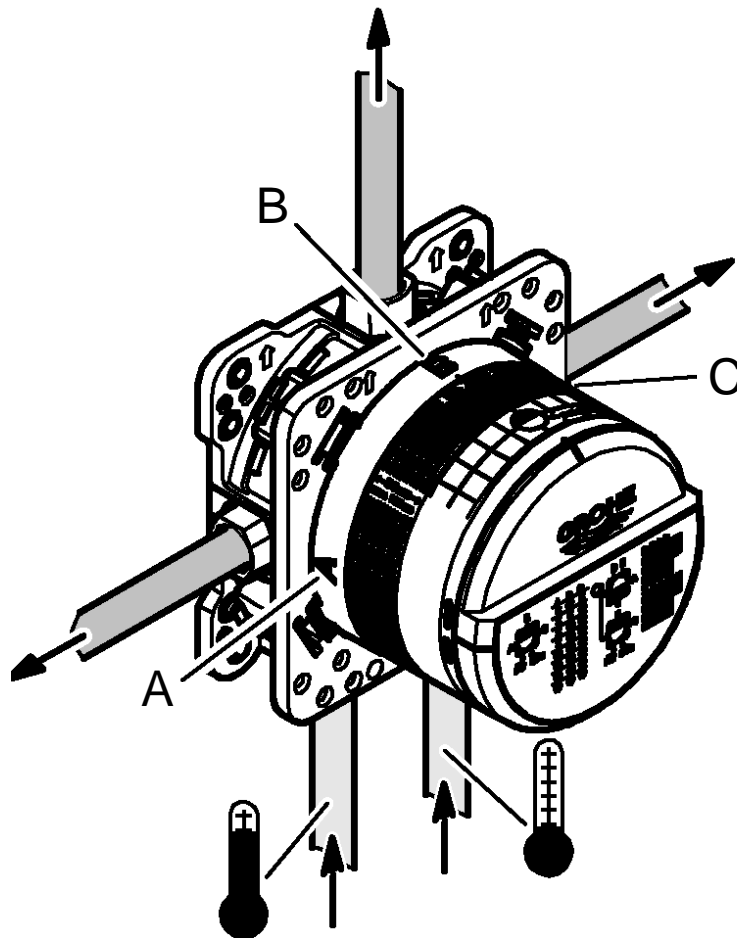
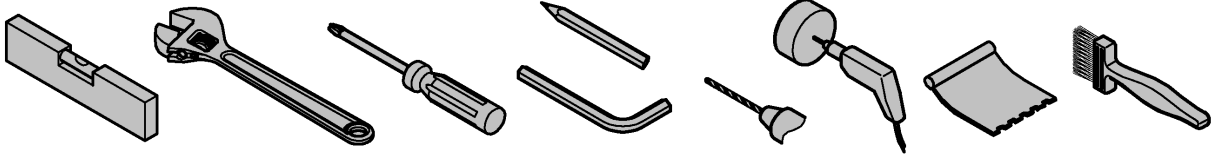

Applications

Operation is possible with:

- Pressurised storage heaters
- Thermally/hydraulically controlled instantaneous water heaters

Operation with unpressurised storage heaters (displacement water heaters) is **not** possible!

Technical data

- Operating pressure: max.145 psi
- Test pressure 232 psi

Note:

To comply with noise levels if static pressure exceeds 72.5 psi, a pressure reducing valve must be fitted.

Installation of the box

- Make drill holes for the box and slots for the pipes.
- Installation depth 2 15/16" - 4 1/8".
- If the box is installed too deeply an extension can be applied.

Installation options, see pages 4-9.

- Installation in studding
- Installation with spacers
- Installation directly on the wall
- Installation in the wall
- Installation on prefabricated house assembly plates or prefabricated shells

Connecting the pipes

The outflows intended for this purpose are to be used.

- Recommended configuration options:
 - Grohtherm SmartControl see from page 11.
- Non-binding outflows must be sealed with the accompanying plug (X).
- Check connections for water-tightness.
- **Plugs (Y) must be assembled**, see page 8, Fig. [6].

Apply carrier material as sealant, see page 9, Fig. [9] to [11].

Plaster and tile the wall.

Do **not** cut the fitting template prior to final installation.

Domaine d'application

Utilisation possible avec :

- Réservoirs sous pression
- Chauffe-eau instantanés hydrauliques/thermiques

Le fonctionnement avec des accumulateurs sans pression (chauffe-eau à écoulement libre) **n'est pas** possible !

Caractéristiques techniques

- Pression de service max.10 bars
- Pression d'épreuve 16 bars

Remarque :

Il est recommandé d'installer un réducteur de pression en cas de pressions statiques supérieures à 5 bars.

Installation du boîtier

- Préparer des trous pour le boîtier et des fentes pour les canalisations.
- Profondeur de montage : 75-105mm.
- Si le boîtier est installé trop en profondeur, il est possible d'utiliser une rallonge.

Possibilités de montage, voir pages 4-9.

- Montage dans un support charpenté
- Montage avec entretoises
- Montage directement sur le mur
- Montage dans le mur
- Montage sur plaques de montage pour préfabriqué ou plaques pré-fabriquées

Brancher les canalisations

Il convient d'utiliser les sorties prévues à cet effet.

- Possibilités de configuration recommandées :
 - Grohtherm SmartControl voir à partir de la page 11.
- Les sorties non obstruées doivent être étanchéifiées à l'aide des bouchons (X) fournis.
- Vérifier l'étanchéité des raccordements.
- **Les bouchons (Y) doit être monté**, voir page 8, fig. [6].

Monter le support pour le produit d'étanchéité, voir page 9, fig. [9] à [11].

Enduire complètement le mur et le carreler.

Ne pas raccourcir le gabarit de montage avant le montage final.

E

Campo de aplicación

Es posible el funcionamiento con:

- Acumuladores de presión
- Calentadores instantáneos con control hidráulico/térmico

No es posible el funcionamiento con acumuladores sin presión (calentadores de agua sin presión).

Datos técnicos

- Presión de utilización máx. 145 psi
- Presión de verificación 232 psi

Nota:

Si la presión en reposo es superior a 72.5 psi, se recomienda instalar un reductor de presión para alcanzar los valores de emisión de ruidos.

Instalación de la caja

- Hacer orificios en la caja así como ranuras en las tuberías.
- Profundidad de montaje 2 15/16" - 4 1/8".
- Si la caja se ha montado en un sitio demasiado profundo, se puede introducir una prolongación.

Posibilidades de montaje, véanse las páginas 4-9.

- Montaje en una pared de tablonos
- Montaje con separador
- Montaje directo en la pared
- Montaje en la pared
- Montaje en placas de montaje de viviendas prefabricadas o células acabadas

Conectar las tuberías

Se deben utilizar las salidas previstas para ello.

- Posibilidades de configuración recomendadas:
 - Véase Grohtherm SmartControl a partir de la página 11.
- Las salidas libres se deben sellar con el tapón suministrado (X).
- Comprobar la estanqueidad de las conexiones.
- **Los tapones (Y) se debe montar**, véase la página 8, fig. [6].

Conseguir material de base para el impermeabilizante, véase la página 9, fig. [9] hasta la [11].

Concluir el enlucido y alicatado de la pared.

No acortar la plantilla de montaje antes de proceder con la instalación de acabado.

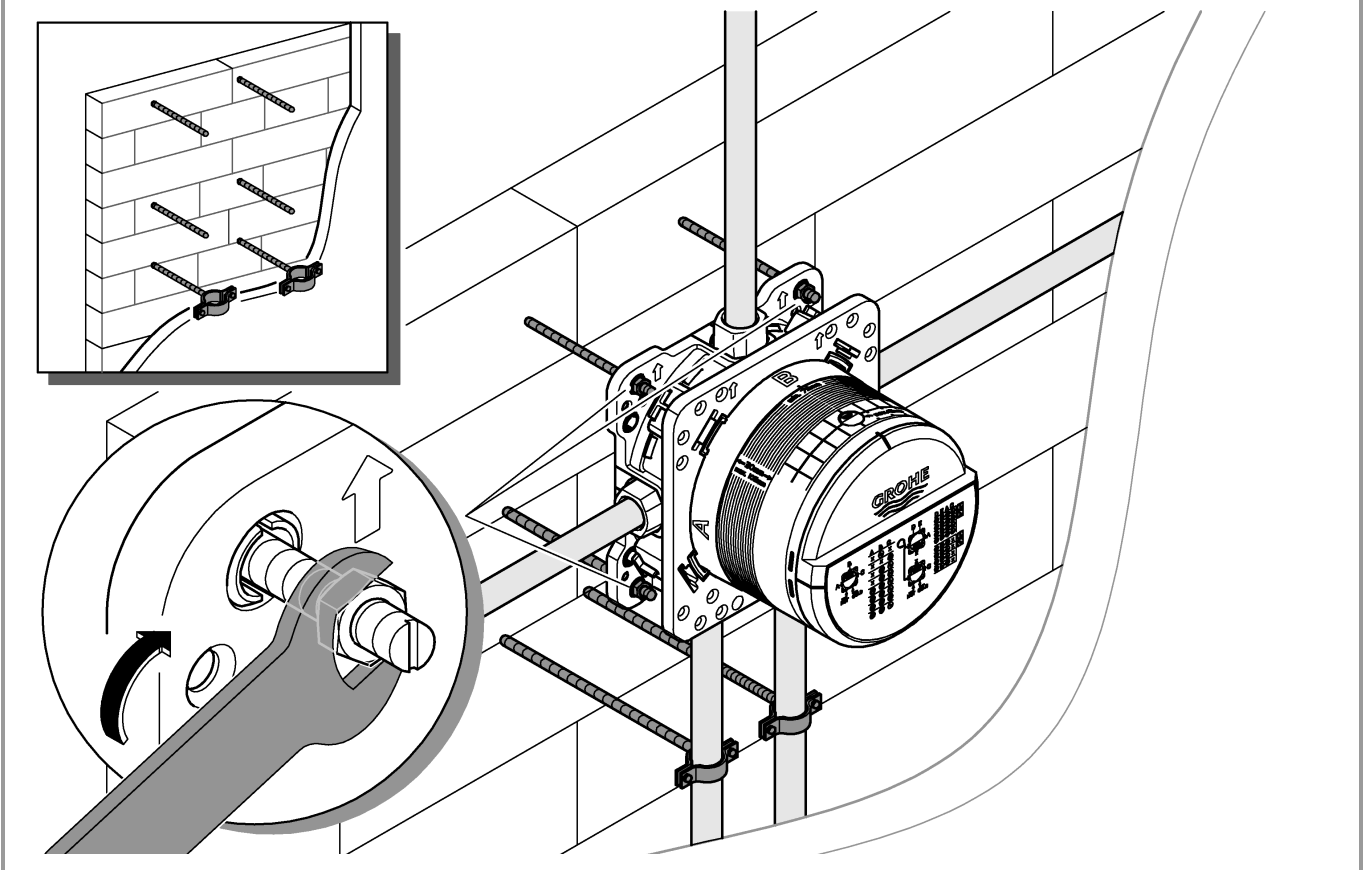
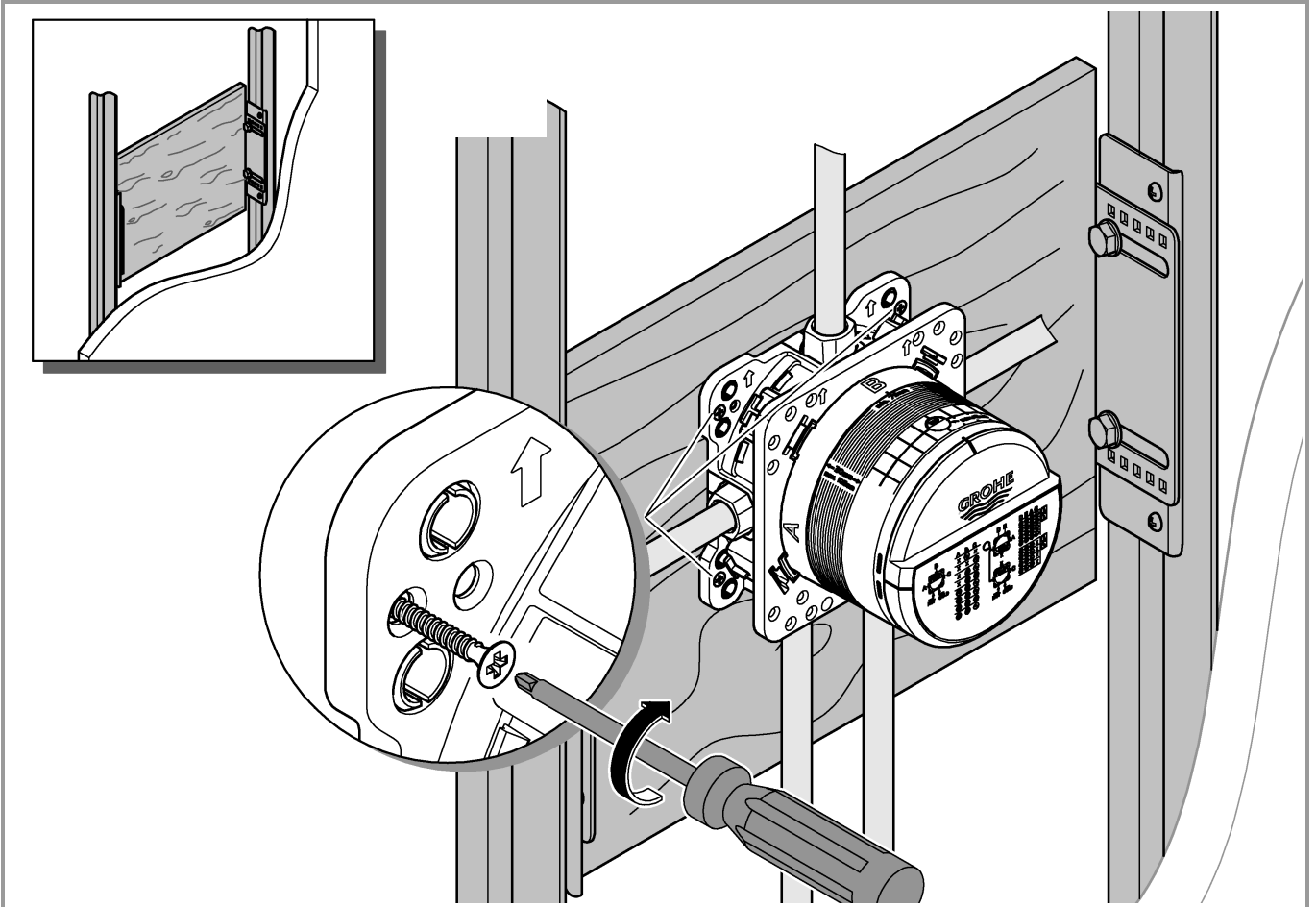

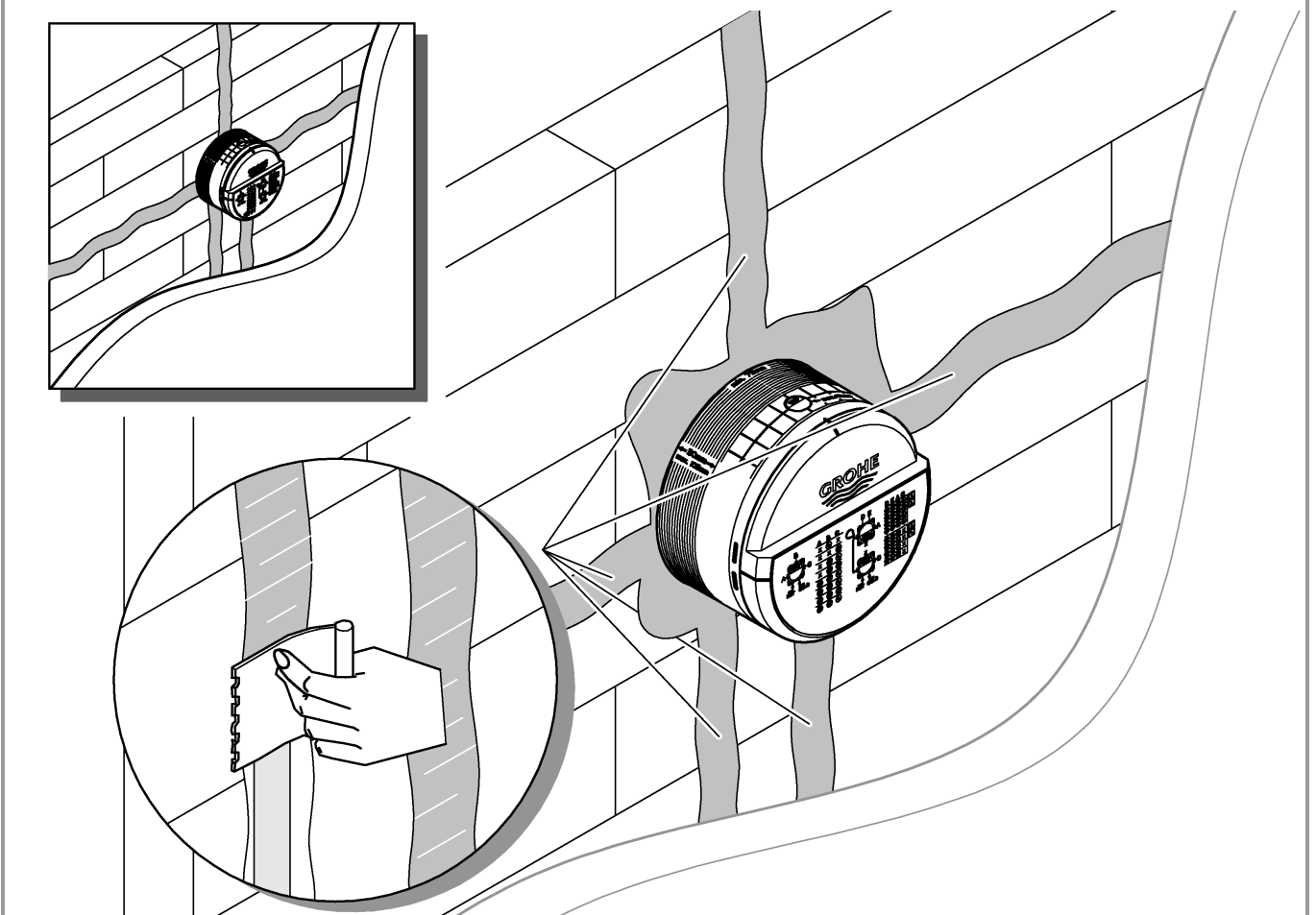
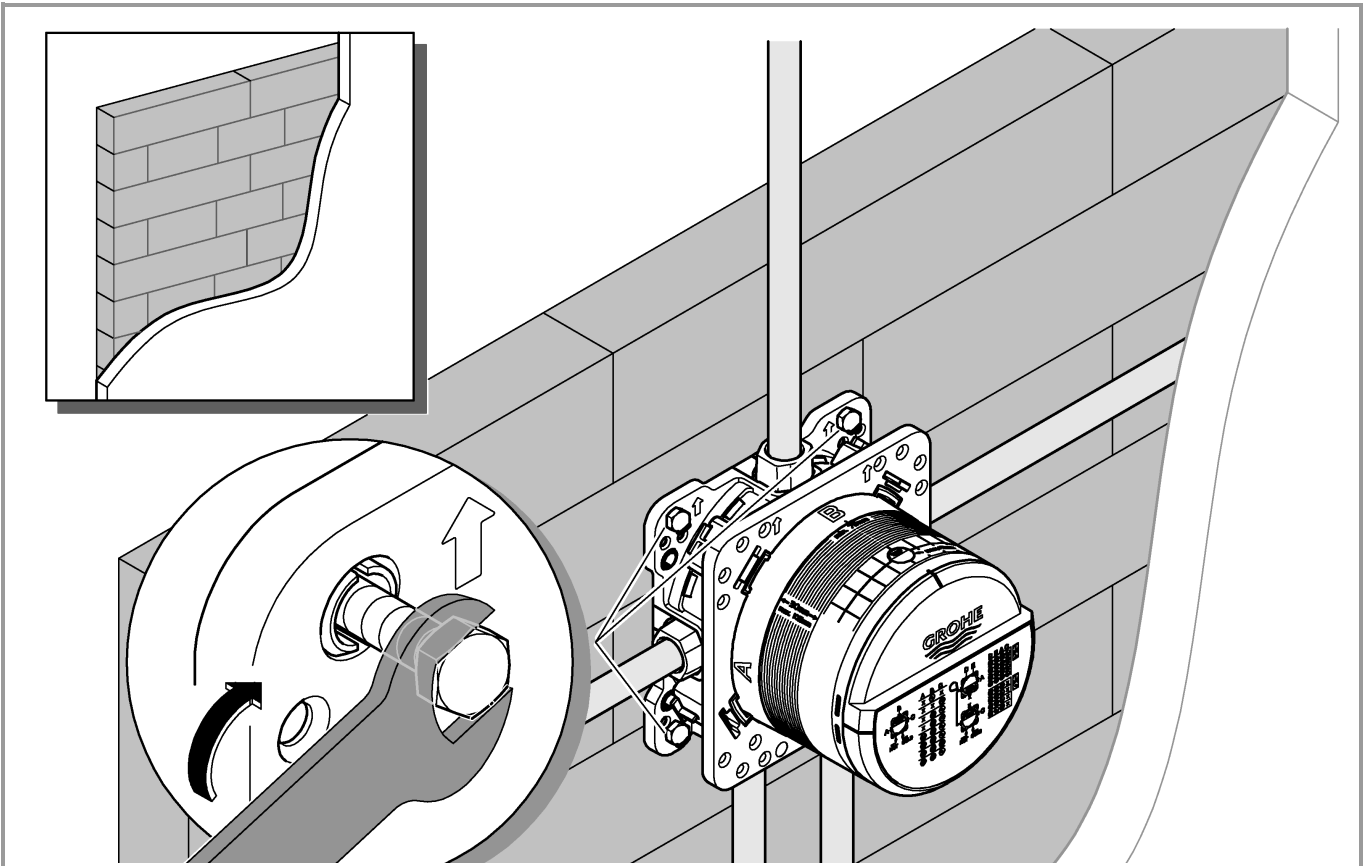

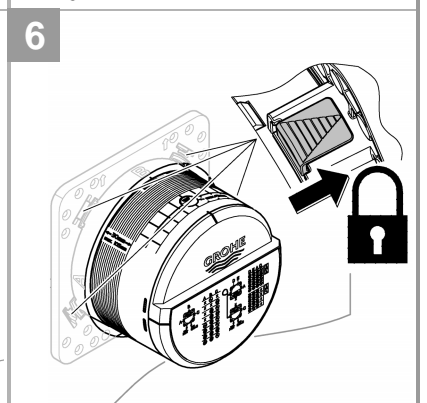
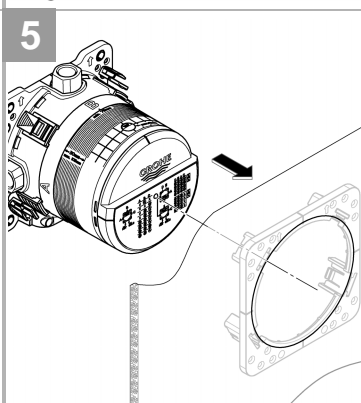
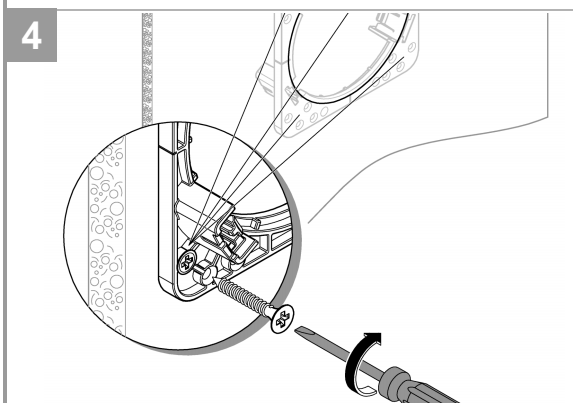
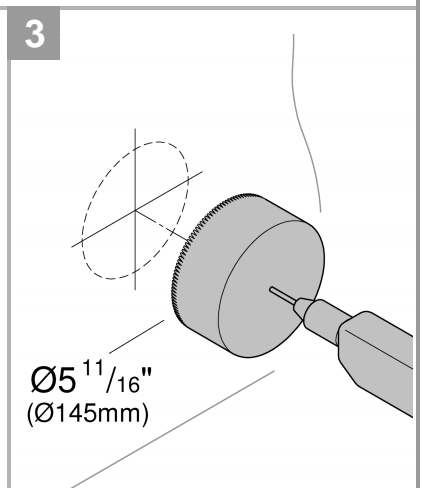
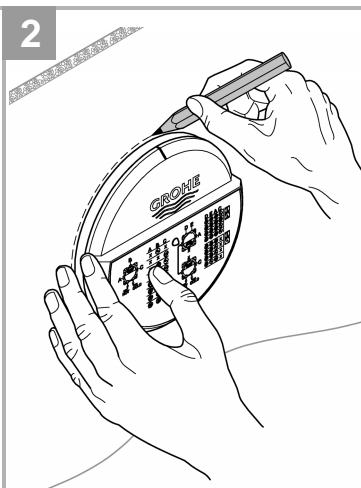
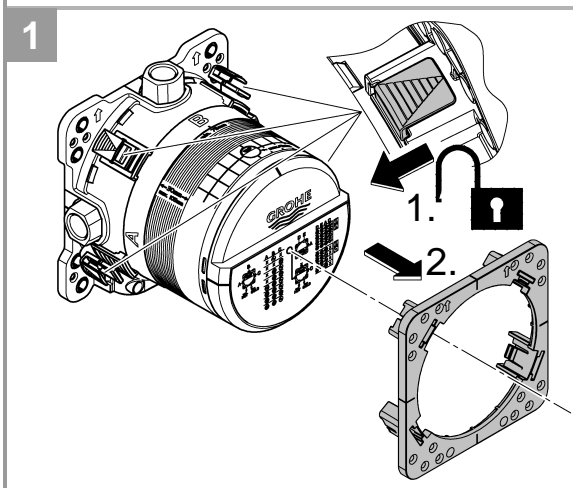
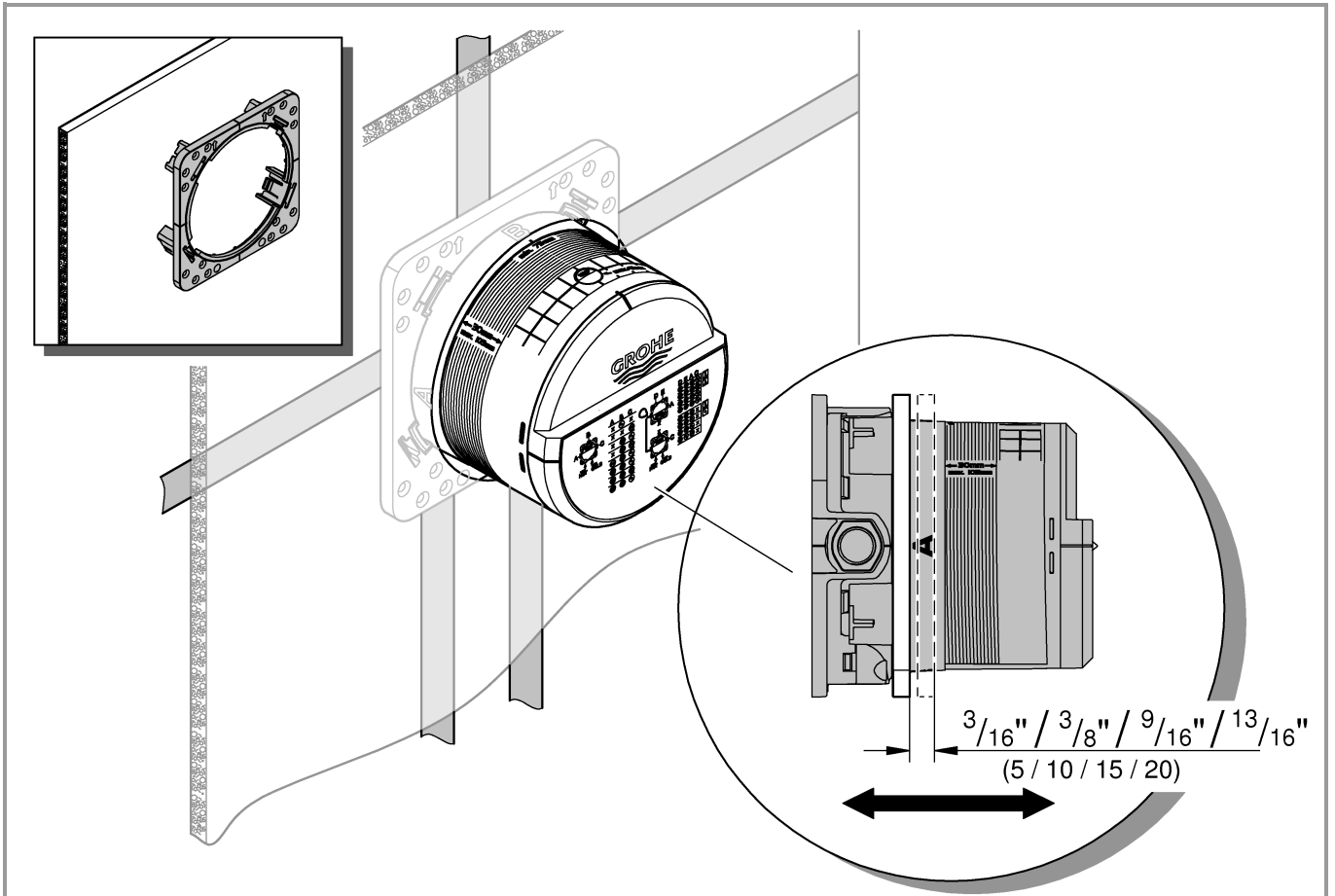



1

Grotherm Smart Control

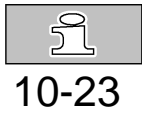
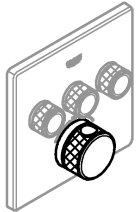

10-23

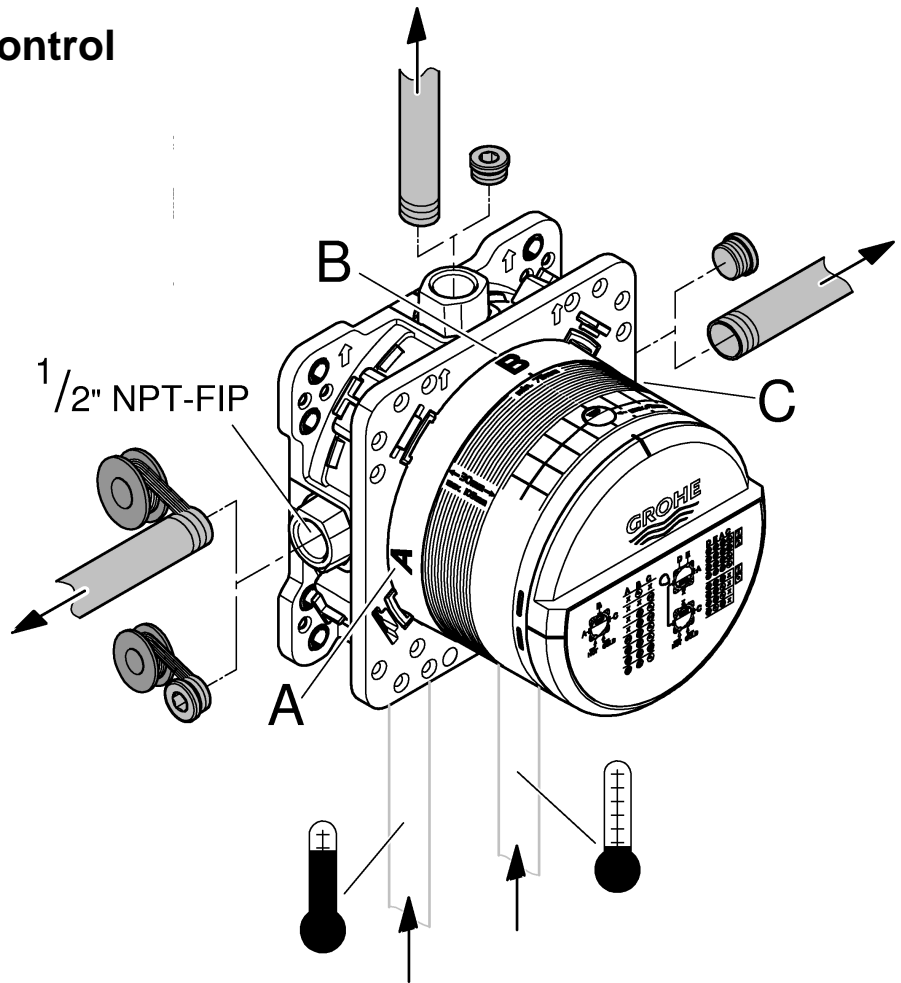
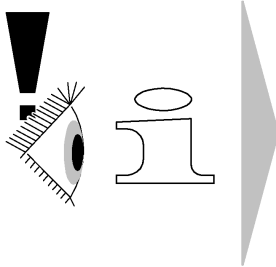

2

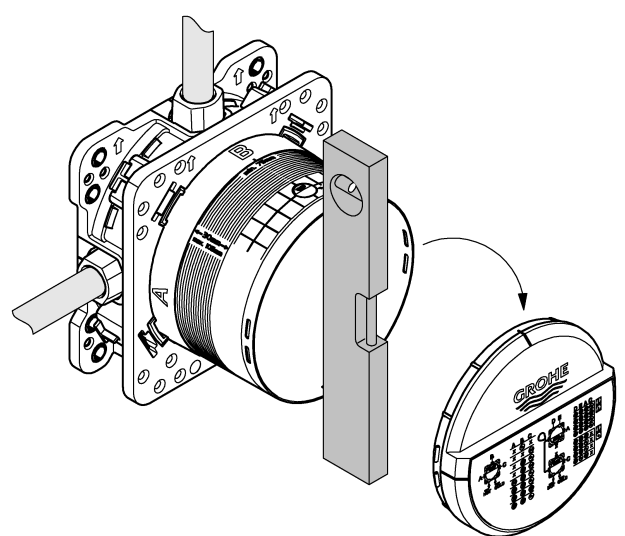
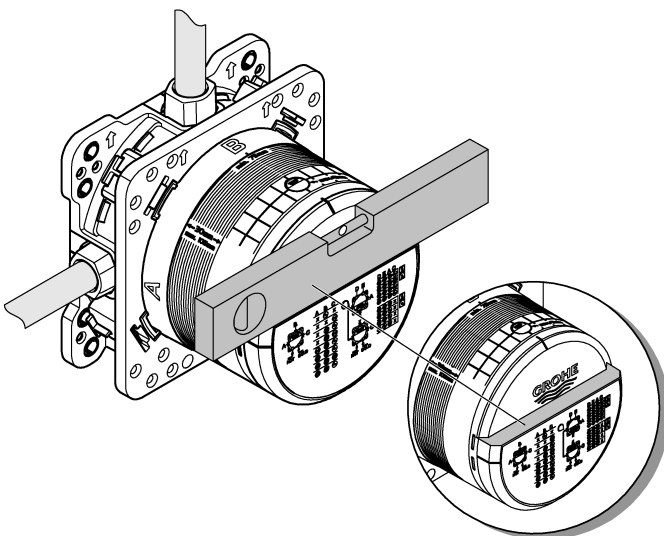



3

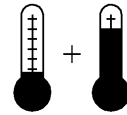
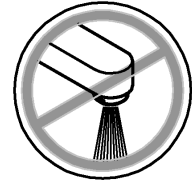
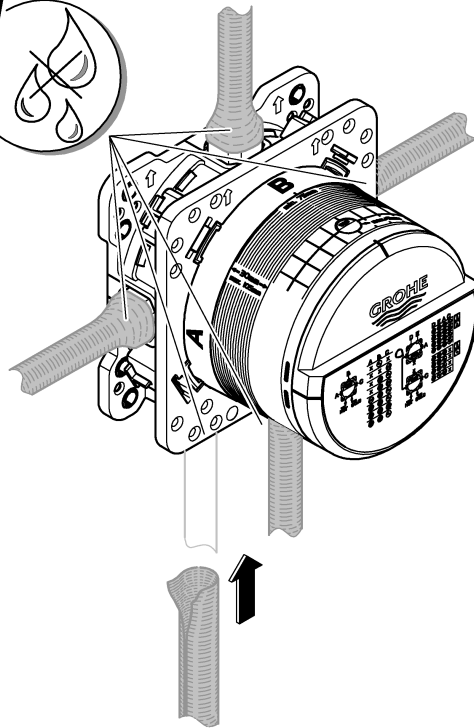
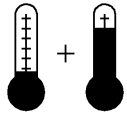
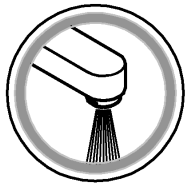

4

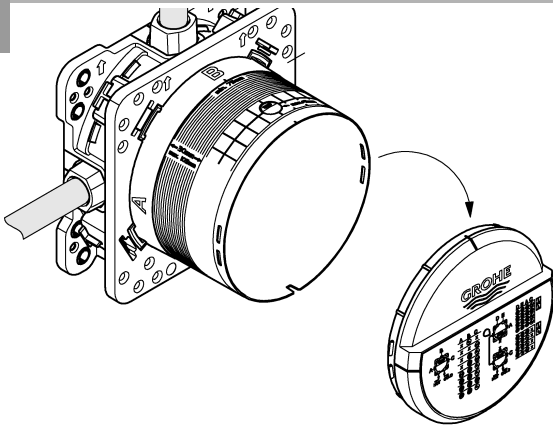

5

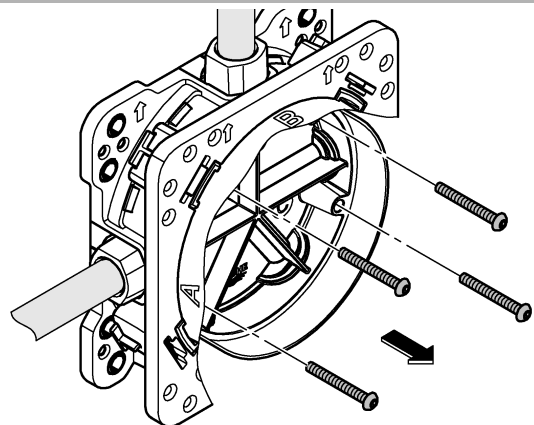

6

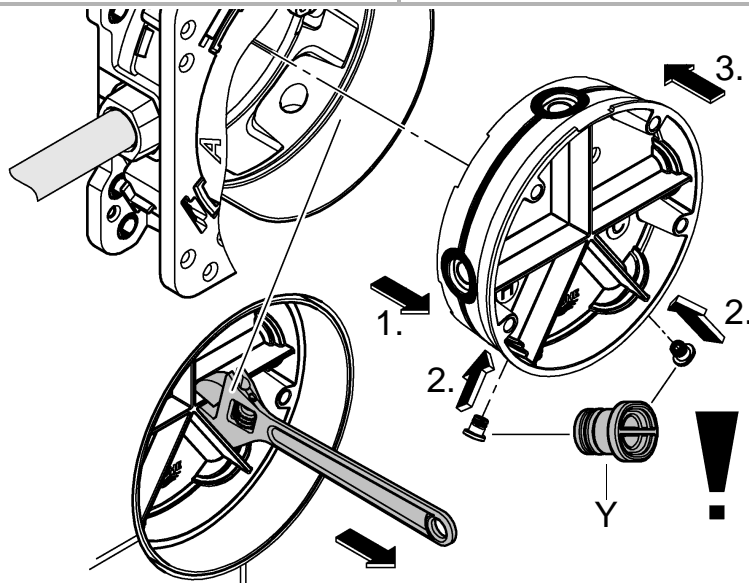



7

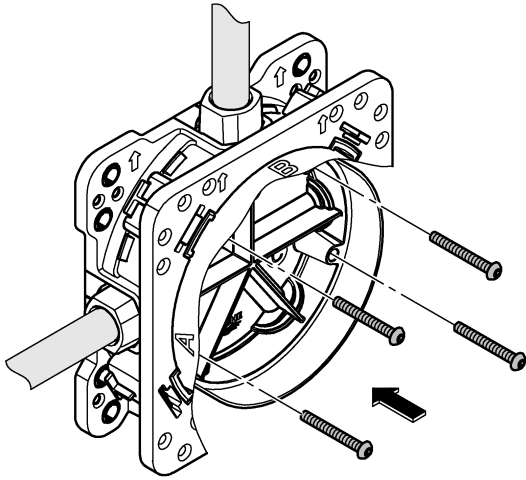

8

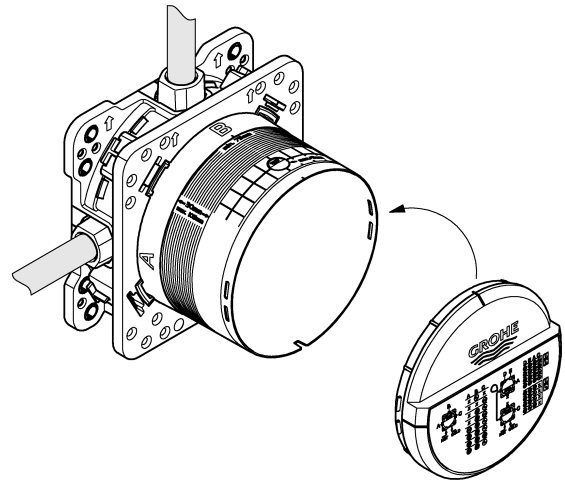

i

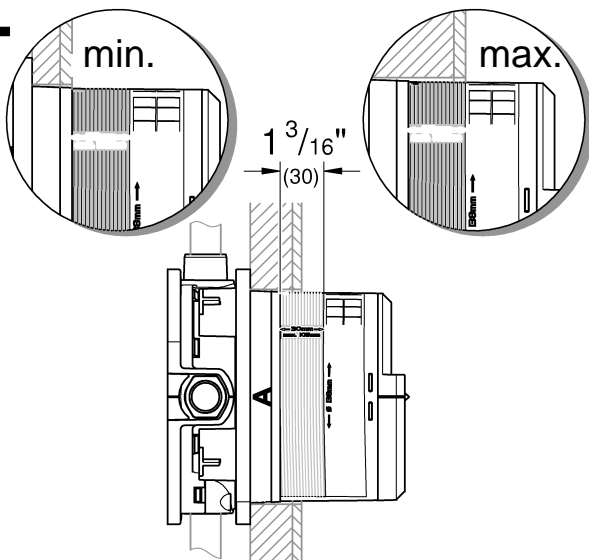

9

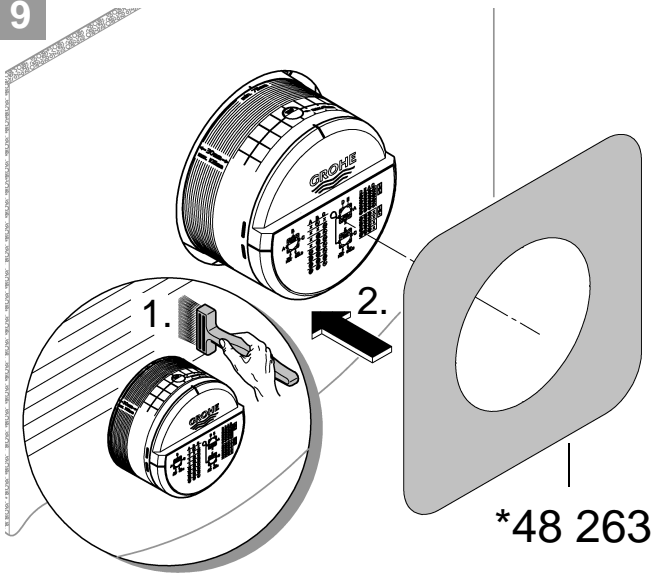

10

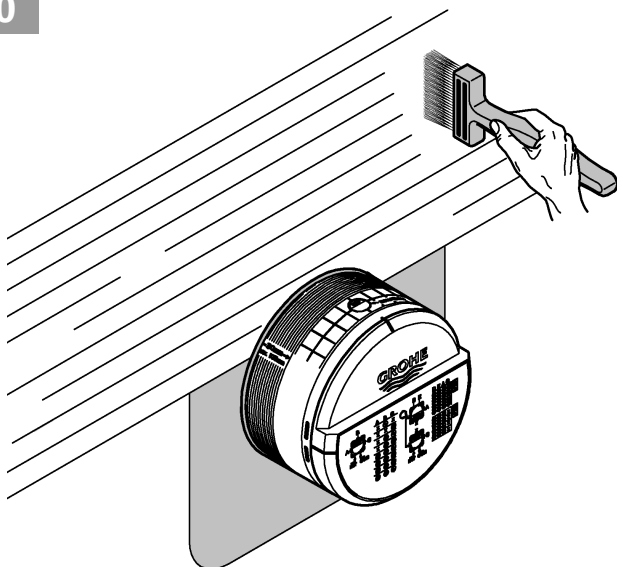

11

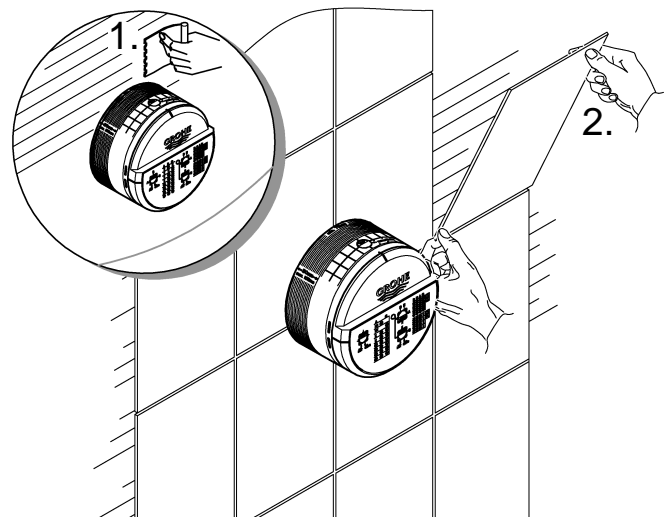

Technical specifications Grotherm SmartControl

Thermostat

- Flow pressure
 - Minimum flow pressure without downstream resistances 7.25 psi
 - Minimum flow pressure with downstream resistances 14.5 psi
 - Recommended 21.75 – 72.5 psi
- Minimum flow rate 1.3 gpm
- Temperature
 - Hot water inlet max. 158 °F
 - Recommended for energy saving 140 °F
 - Thermal disinfection possible
- Hot water temperature at supply connection min. 3.6 °F higher than mixed water temperature

Flow rates without downstream resistances, see page 12-23. **These are to be observed when dimensioning the outlet!**

- Installation options, see page 11.
- Recommended configuration options, see from page 12.

The following special accessories are available:

- Extension 1" (prod. no.: 14 048)
- Service stops (prod. no.: 14 053)
- Reversed connection, hot on right – cold on left replace thermostat cartridges (prod. no.: 49 003)

Caractéristiques techniques Grotherm SmartControl

Thermostat

- Pression dynamique
 - Pression dynamique minimale sans résistances en aval 0,5 bar
 - Pression dynamique minimale avec résistances en aval 1 bar
 - Recommandée 1,5 à 5 bars
- Débit minimal 5 l/min
- Température
 - Arrivée d'eau chaude max. 70 °C
 - Recommandée pour une économie d'énergie 60 °C
 - Désinfection thermique possible
- Température de l'eau chaude au raccord d'alimentation au moins 2 °C de plus que la température de l'eau mitigée

Débits sans résistances en aval, voir pages 12-23.

Veillez en tenir compte lors du dimensionnement de l'évacuation!

- Possibilités de montage, voir page 11.
- Possibilités de configuration recommandées, voir à partir de la page 12.

Les accessoires spéciaux suivants sont disponibles :

- Rallonge de 25mm (réf. : 14 048)
- Robinets d'arrêt (réf. : 14 053)
- Raccordement inversé, chaud à droite - froid à gauche, remplacer la cartouche du thermostat (réf. : 49 003)

Datos técnicos de Grotherm SmartControl

Thermostat

- Presión de trabajo
 - Presión mínima de trabajo sin resistencias posacopladas 7.25 psi
 - Presión mínima de trabajo con resistencias posacopladas 14.5 psi
 - Presión recomendada 21.75 – 72.5 psi
- Caudal mínimo 1.3 gpm
- Temperatura
 - Entrada de agua caliente máx. 158 °F
 - Recomendada para ahorrar energía 140 °F
 - Desinfección térmica posible
- La temperatura del agua caliente en la acometida mín. 3.6 °F superior a la temperatura del agua mezclada

Caudales sin resistencias posacopladas, véanse las páginas 12-23. **Tenga en cuenta las dimensiones del desagüe.**

- Posibilidades de montaje, véase la página 11.
- Posibilidades de configuración recomendadas, véase a partir de la página 12.

Los siguientes accesorios opcionales están disponibles:

- Prolongación de 1" (n.º de pedido: 14 048)
- Bloqueos de seguridad (n.º de pedido: 14 053)
- Conexión invertida, derecha caliente - izquierda frío sustituir los cartuchos del termostato (n.º de pedido: 49 003)

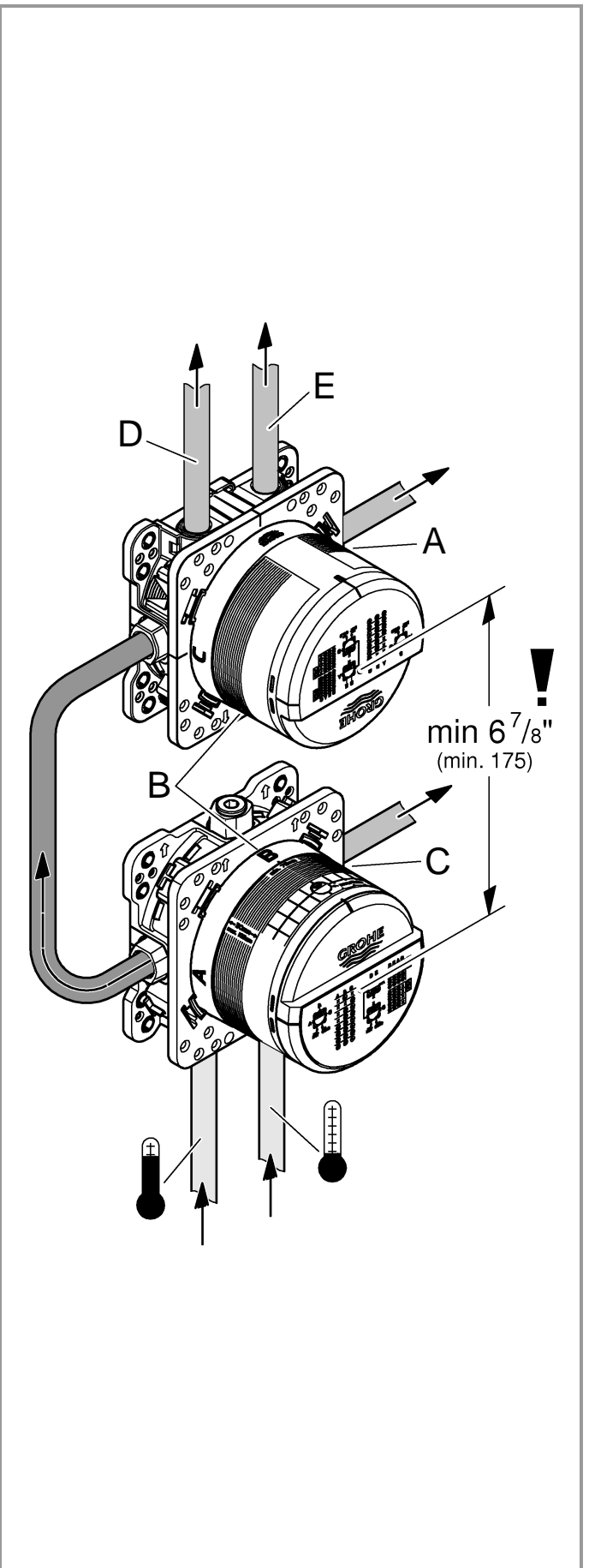
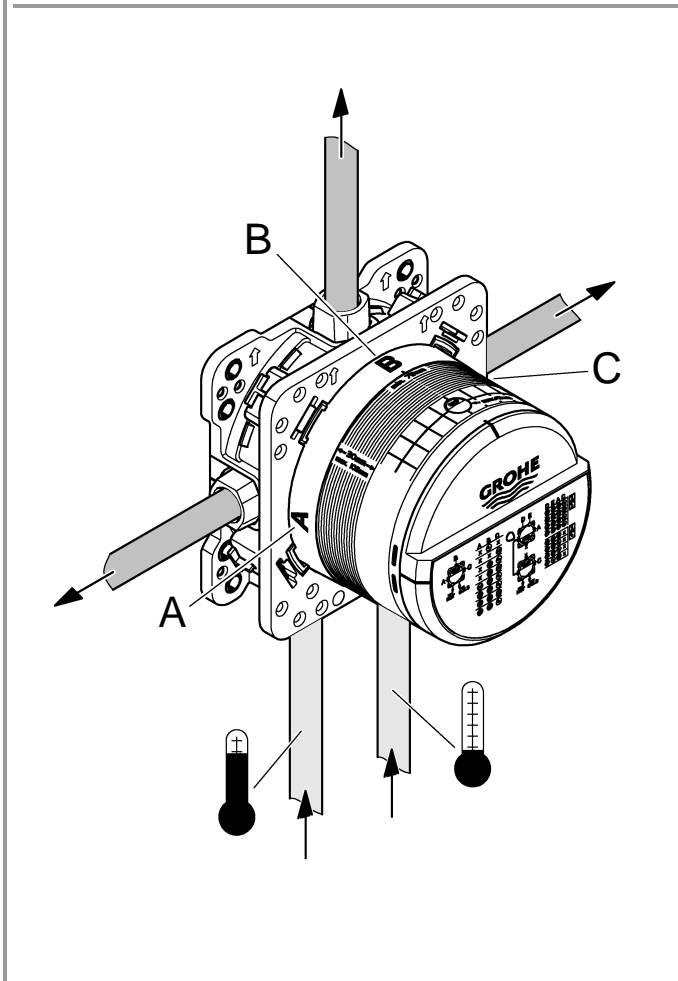
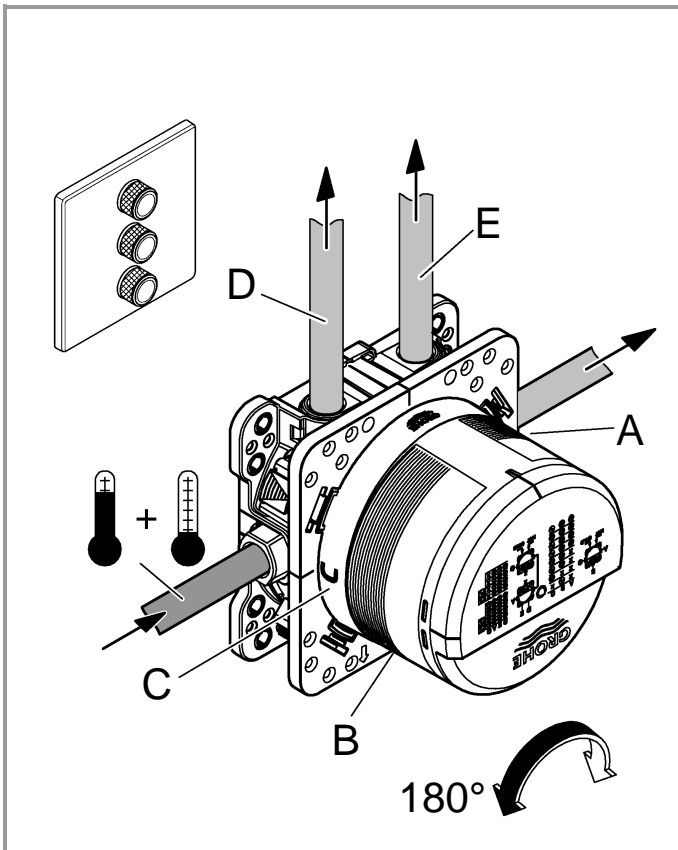



Grohtherm SmartControl

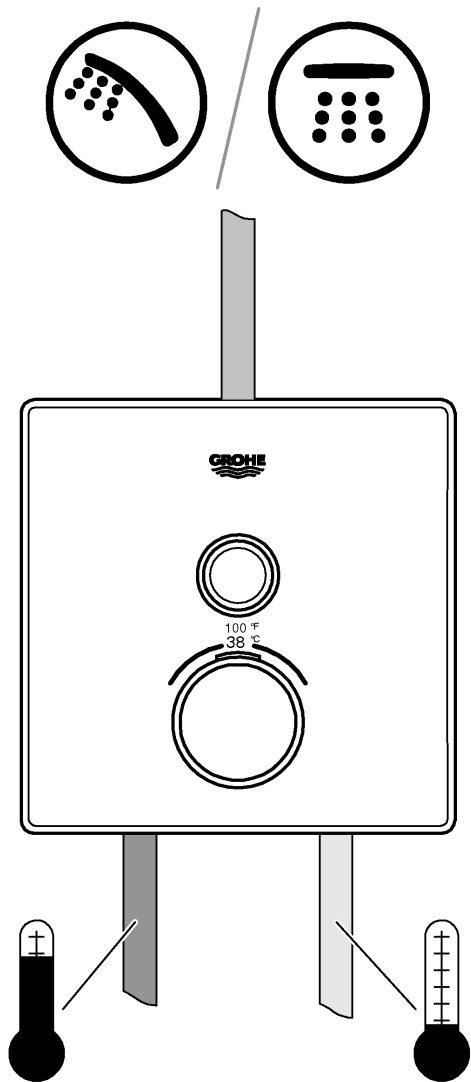

	psi						gpm
	14,5	29	43,5	58	72,5	87	
B	4,4	6,3	7,7	8,8	9,9	10,8	

	bar						l/min
	1	2	3	4	5	6	
B	16,7	23,7	29	33,5	37,4	41	

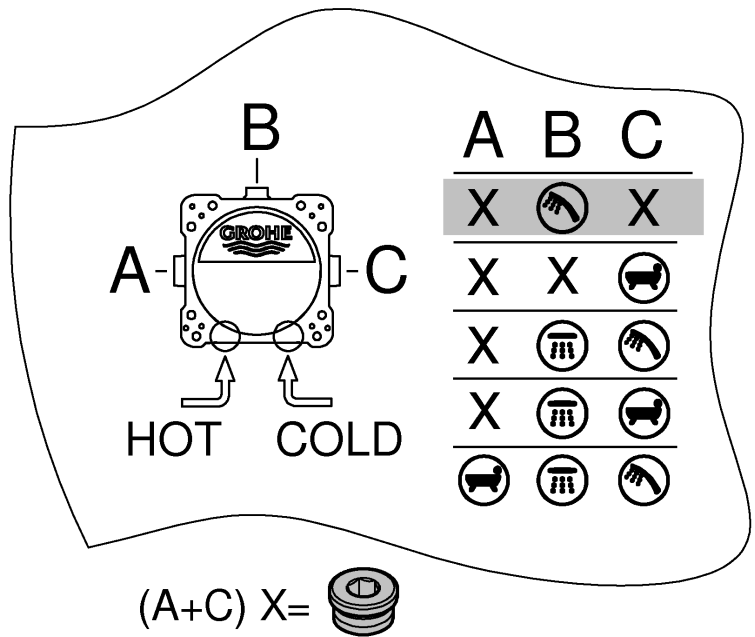



Grohtherm SmartControl

	psi						gpm
	14,5	29	43,5	58	72,5	87	
C	4,4	6,3	7,7	8,8	9,9	10,8	

	bar						l/min
	1	2	3	4	5	6	
C	16,7	23,7	29	33,5	37,4	41	

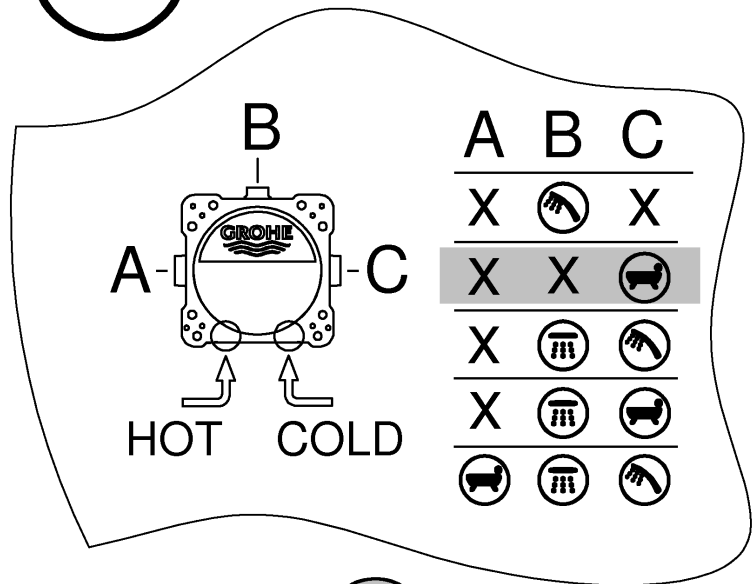
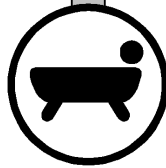
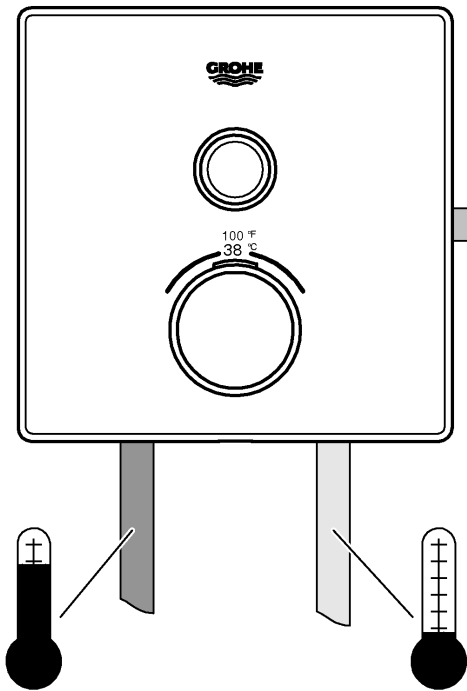

(A+B) X=



Grohtherm SmartControl

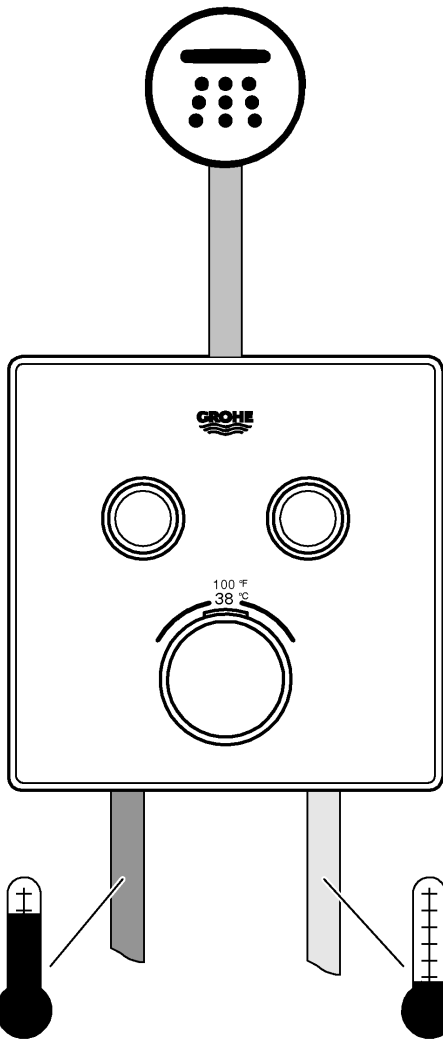

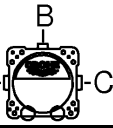
A-  -C	psi						gpm
	14,5	29	43,5	58	72,5	87	
B	3,7	5,2	6,3	7,3	8,2	9	
C	4	5,6	6,9	7,9	8,9	9,7	
B + C	4,4	6,3	7,7	8,8	9,9	10,8	

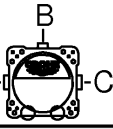
A-  -C	bar						l/min
	1	2	3	4	5	6	
B	13,9	19,6	24	27,7	31	33,9	
C	15	21,2	26	30	33,6	36,8	
B + C	16,7	23,7	29	33,5	37,4	41	

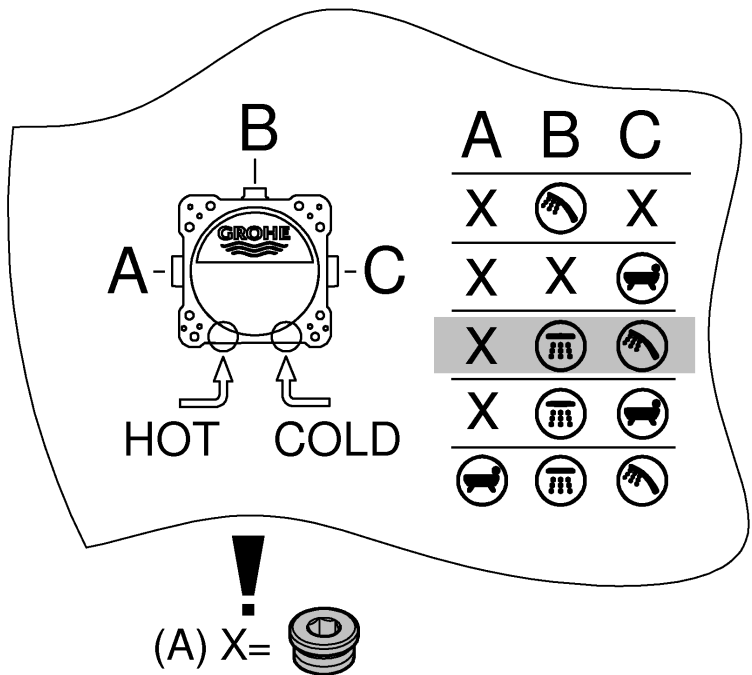



Grohtherm SmartControl

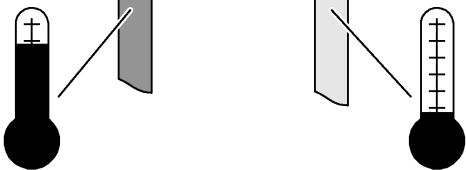
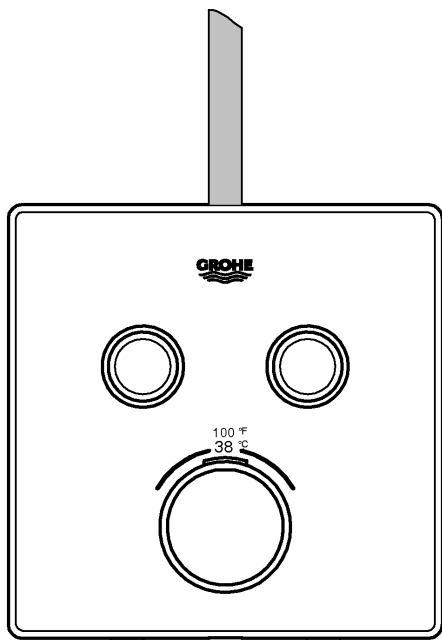
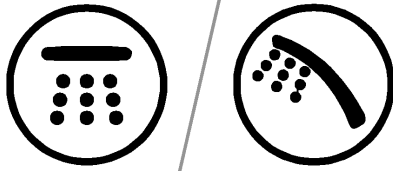

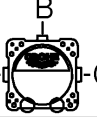

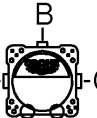
	psi						gpm
	14,5	29	43,5	58	72,5	87	
B	3,7	5,2	6,3	7,3	8,2	9	
C	4	5,6	6,9	7,9	8,9	9,7	
B + C	4,4	6,3	7,7	8,8	9,9	10,8	

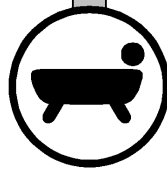
	bar						l/min
	1	2	3	4	5	6	
B	13,9	19,6	24	27,7	31	33,9	
C	15	21,2	26	30	33,6	36,8	
B + C	16,7	23,7	29	33,5	37,4	41	

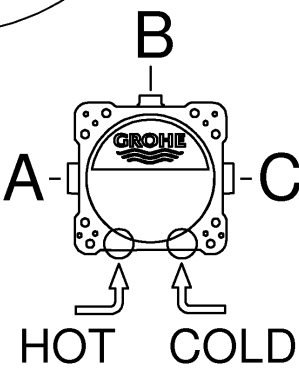

	A	B	C
X		X	
X	X		
X			
X			
X			



(A) X = 

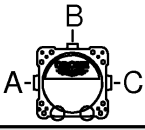

Grohtherm SmartControl

	psi						gpm
	14,5	29	43,5	58	72,5	87	
A	3,5	5	6,1	7	7,8	8,6	
B	4,1	5,8	7,1	8,2	9,2	10,1	
C	3,5	5	6,1	7	7,8	8,6	
A+B	5	7,1	8,7	10,1	11,3	12,3	
A+B+C	5,5	7,8	9,5	11	12,3	13,4	

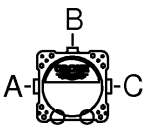
	bar						l/min
	1	2	3	4	5	6	
A	13,3	18,8	23	26,6	29,7	32,5	
B	15,6	22	27	31,2	34,9	38,2	
C	13,3	18,8	23	26,6	29,7	32,5	
A+B	19,1	26,9	33	38,1	42,6	46,7	
A+B+C	20,8	29,4	36	41,6	46,5	50,9	

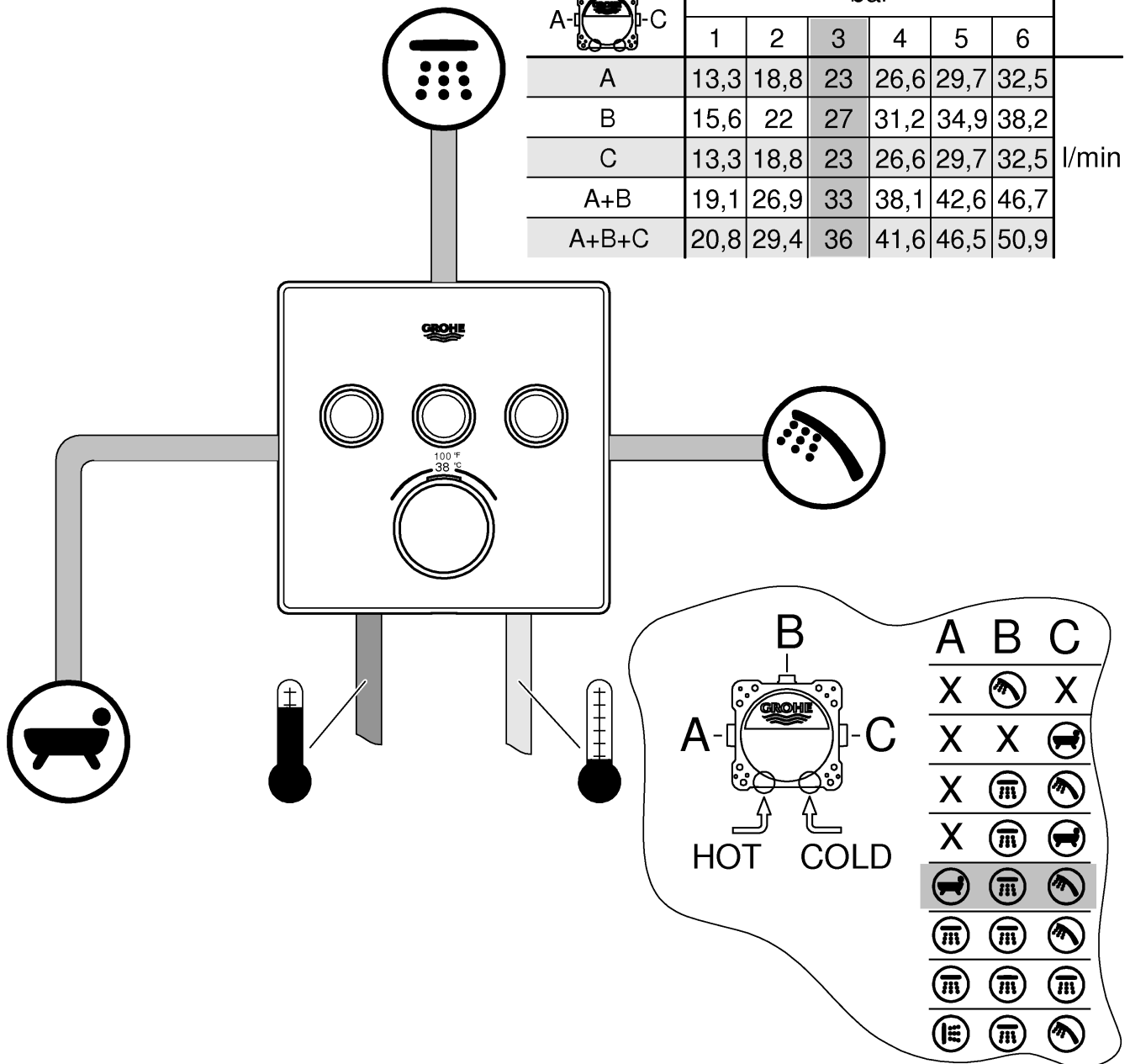

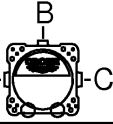

Grotherm SmartControl

	psi						gpm
	14,5	29	43,5	58	72,5	87	
A	3,5	5	6,1	7	7,8	8,6	
B	4,1	5,8	7,1	8,2	9,2	10,1	
C	3,5	5	6,1	7	7,8	8,6	
A+B	5	7,1	8,7	10,1	11,3	12,3	
A+B+C	5,5	7,8	9,5	11	12,3	13,4	

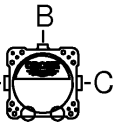
	bar						l/min
	1	2	3	4	5	6	
A	13,3	18,8	23	26,6	29,7	32,5	
B	15,6	22	27	31,2	34,9	38,2	
C	13,3	18,8	23	26,6	29,7	32,5	
A+B	19,1	26,9	33	38,1	42,6	46,7	
A+B+C	20,8	29,4	36	41,6	46,5	50,9	

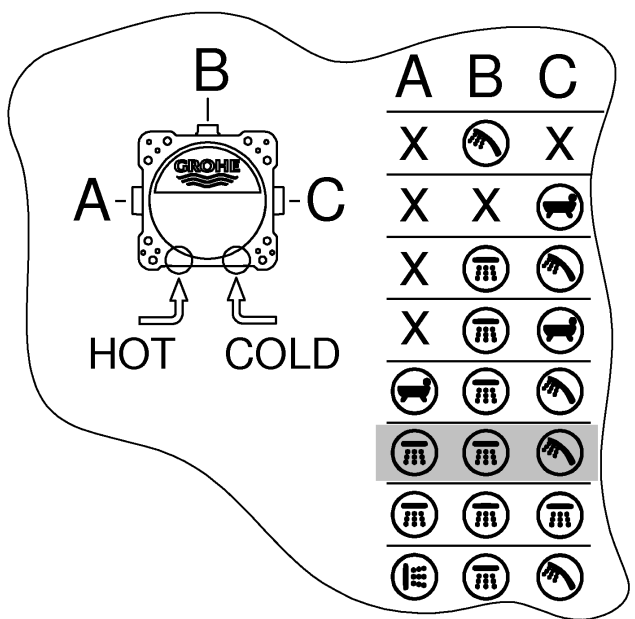
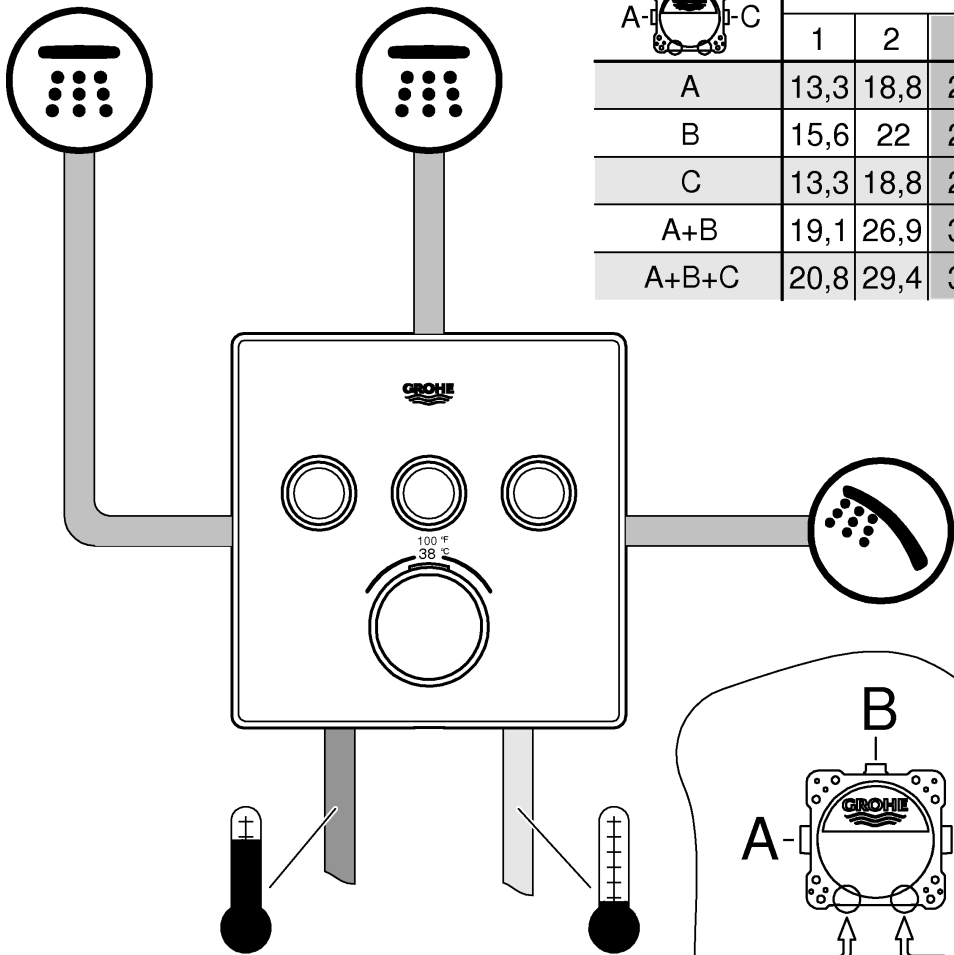

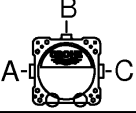

Grotherm SmartControl

	bar					
	1	2	3	4	5	6
A	13,3	18,8	23	26,6	29,7	32,5
B	15,6	22	27	31,2	34,9	38,2
C	13,3	18,8	23	26,6	29,7	32,5
A+B	19,1	26,9	33	38,1	42,6	46,7
A+B+C	20,8	29,4	36	41,6	46,5	50,9

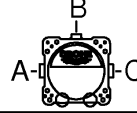
	psi					
	14,5	29	43,5	58	72,5	87
A	3,5	5	6,1	7	7,8	8,6
B	4,1	5,8	7,1	8,2	9,2	10,1
C	3,5	5	6,1	7	7,8	8,6
A+B	5	7,1	8,7	10,1	11,3	12,3
A+B+C	5,5	7,8	9,5	11	12,3	13,4

l/min

gpm

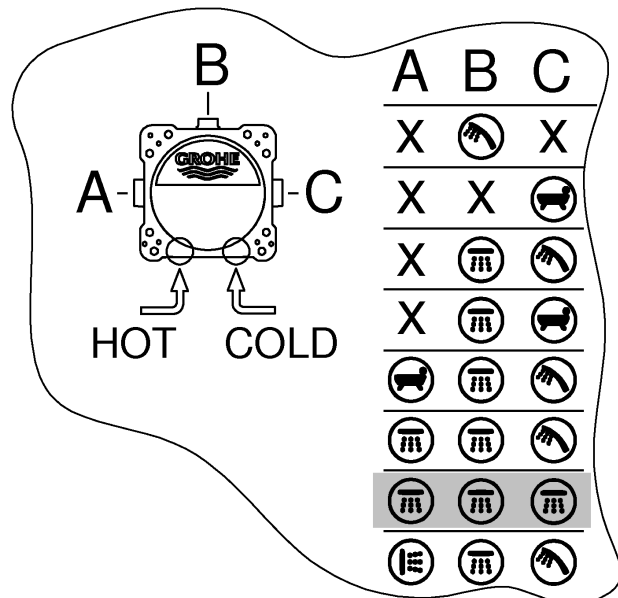
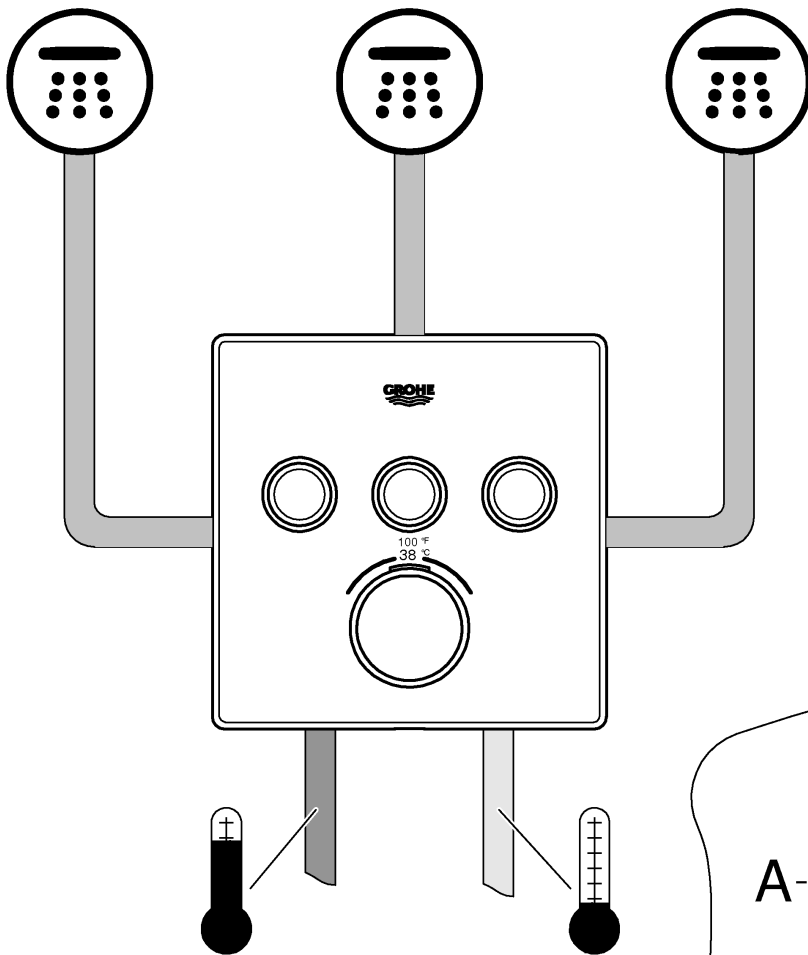

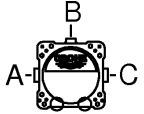

Grotherm SmartControl

	bar						l/min
	1	2	3	4	5	6	
A	13,3	18,8	23	26,6	29,7	32,5	
B	15,6	22	27	31,2	34,9	38,2	
C	13,3	18,8	23	26,6	29,7	32,5	
A+B	19,1	26,9	33	38,1	42,6	46,7	
A+B+C	20,8	29,4	36	41,6	46,5	50,9	

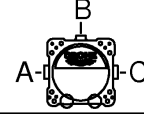
	psi						gpm
	14,5	29	43,5	58	72,5	87	
A	3,5	5	6,1	7	7,8	8,6	
B	4,1	5,8	7,1	8,2	9,2	10,1	
C	3,5	5	6,1	7	7,8	8,6	
A+B	5	7,1	8,7	10,1	11,3	12,3	
A+B+C	5,5	7,8	9,5	11	12,3	13,4	

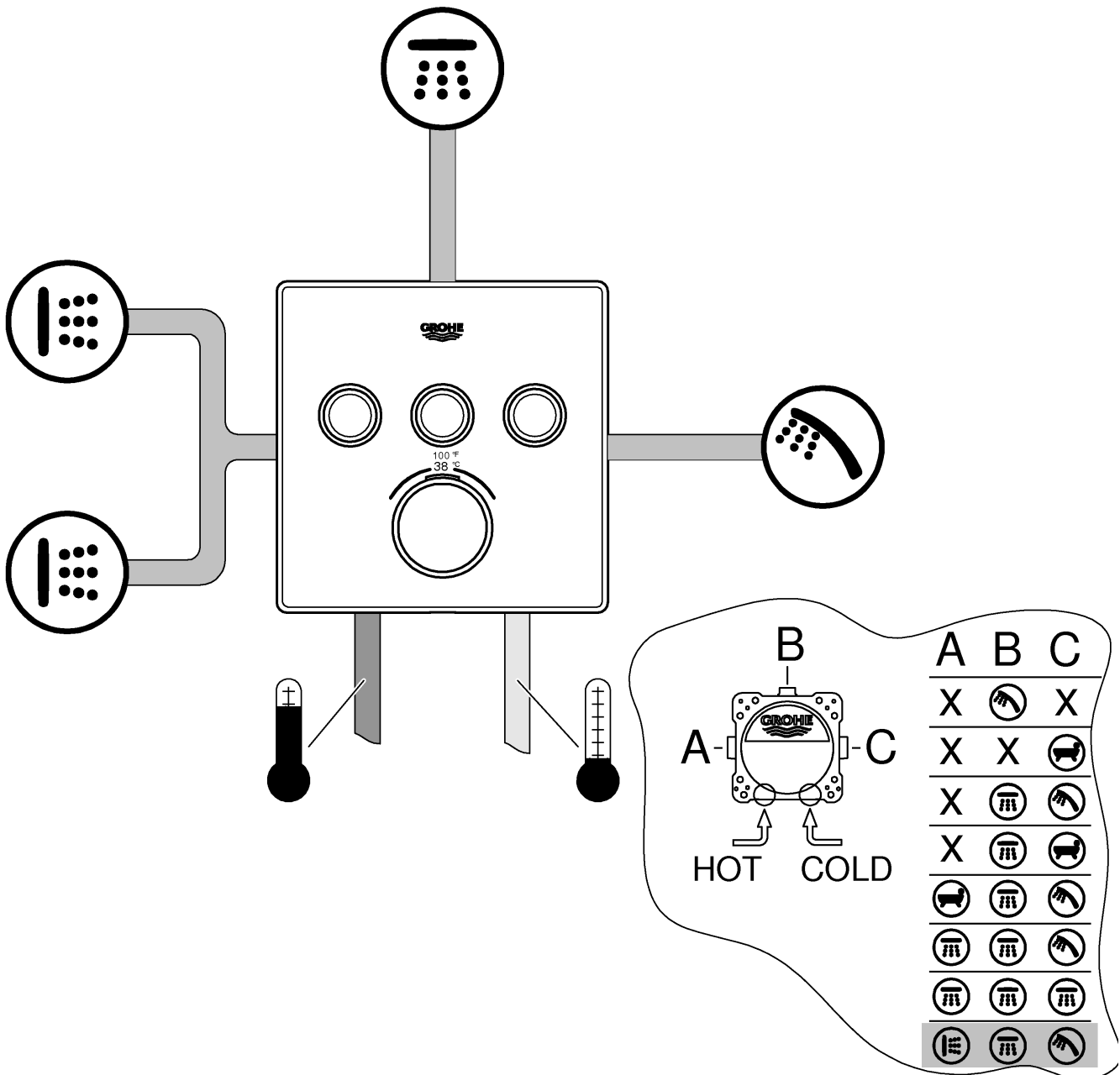

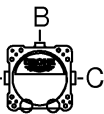

Grotherm SmartControl

	psi					
	14,5	29	43,5	58	72,5	87
D	3,2	4,5	5,5	6,4	7,2	7,8
E	3,2	4,5	5,5	6,4	7,2	7,8
A	3,2	4,5	5,5	6,4	7,2	7,8
C	4,4	6,3	7,7	8,8	9,9	10,8
D+E+A	4,4	6,3	7,7	8,8	9,9	10,8
D+E+A+C	5,5	7,8	9,5	11	12,3	13,4

gpm

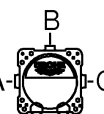
	bar					
	1	2	3	4	5	6
D	12,1	17,1	21	24,2	27,1	29,7
E	12,1	17,1	21	24,2	27,1	29,7
A	12,1	17,1	21	24,2	27,1	29,7
C	16,7	23,7	29	33,5	37,4	41
D+E+A	16,7	23,7	29	33,5	37,4	41
D+E+A+C	20,8	29,4	36	41,6	46,5	50,9

l/min

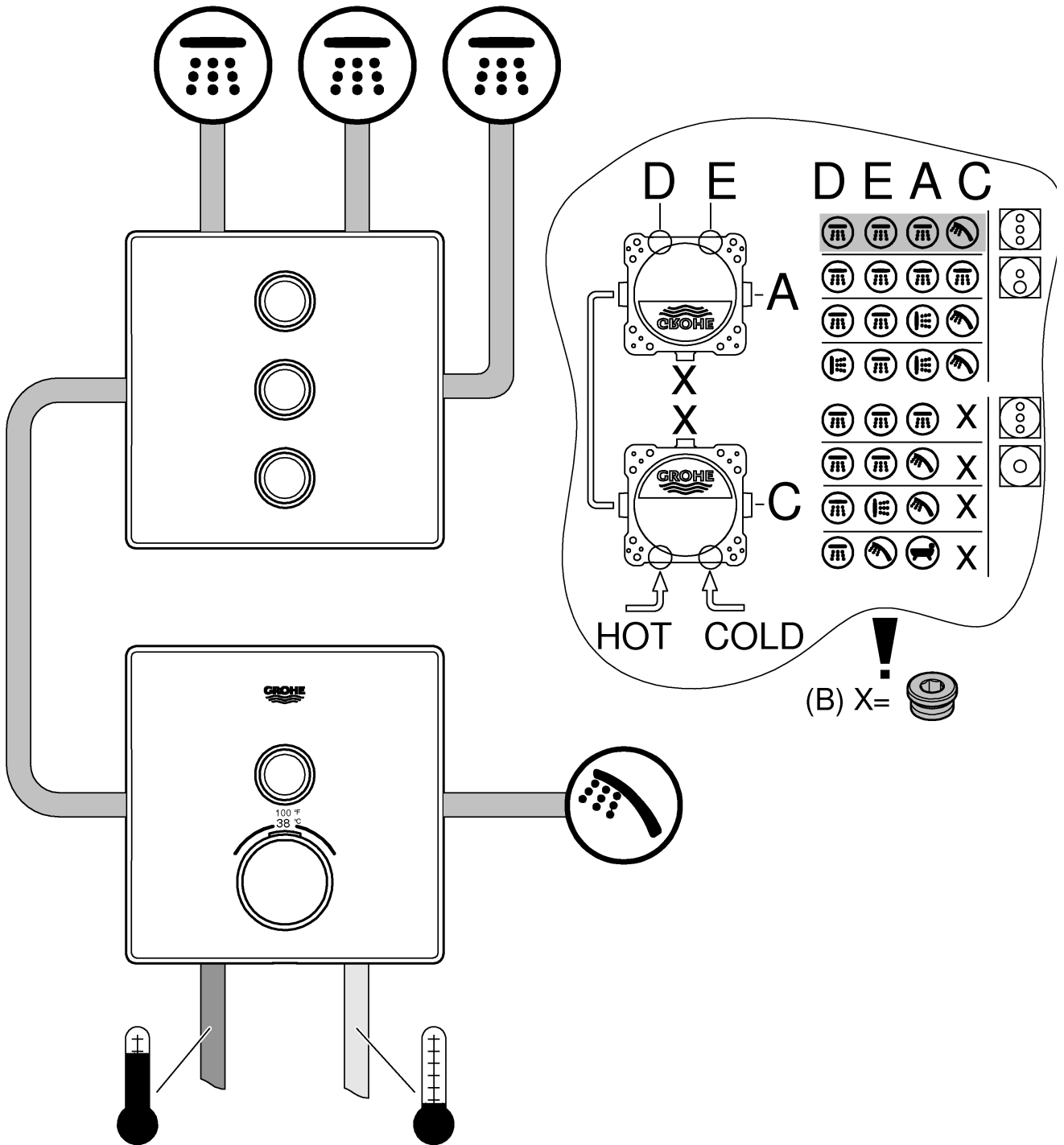



Grotherm SmartControl

A-B-C	psi						gpm
	14,5	29	43,5	58	72,5	87	
D	3,2	4,5	5,5	6,4	7,2	7,8	
E	3,2	4,5	5,5	6,4	7,2	7,8	
A	3,2	4,5	5,5	6,4	7,2	7,8	
C	4,4	6,3	7,7	8,8	9,9	10,8	
D+E+A	4,4	6,3	7,7	8,8	9,9	10,8	
D+E+A+C	5,5	7,8	9,5	11	12,3	13,4	

A-B-C	bar						l/min
	1	2	3	4	5	6	
D	12,1	17,1	21	24,2	27,1	29,7	
E	12,1	17,1	21	24,2	27,1	29,7	
A	12,1	17,1	21	24,2	27,1	29,7	
C	16,7	23,7	29	33,5	37,4	41	
D+E+A	16,7	23,7	29	33,5	37,4	41	
D+E+A+C	20,8	29,4	36	41,6	46,5	50,9	

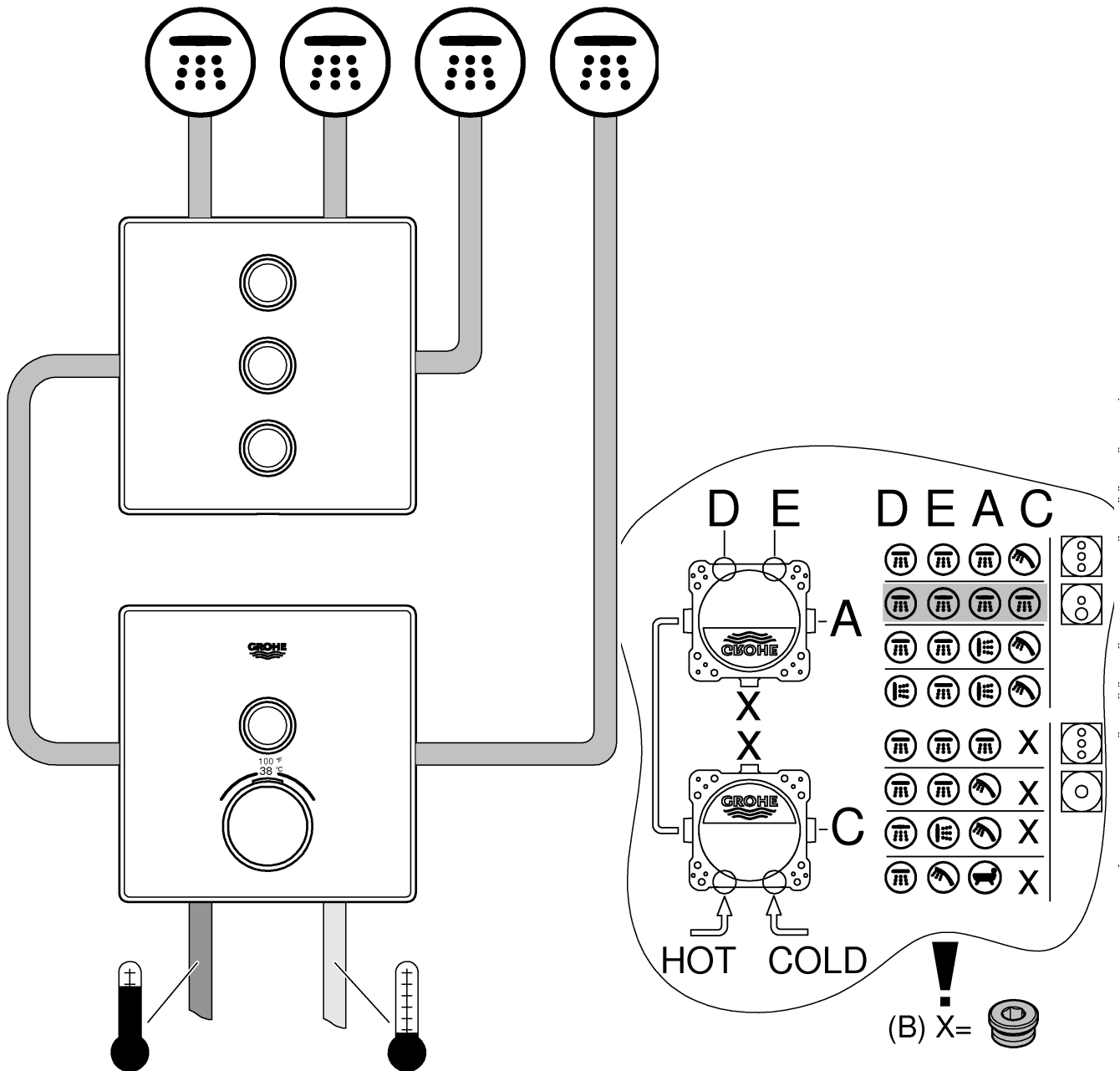



Grotherm SmartControl

A-B-C	psi					
	14,5	29	43,5	58	72,5	87
D	3,2	4,5	5,5	6,4	7,2	7,8
E	3,2	4,5	5,5	6,4	7,2	7,8
A	3,2	4,5	5,5	6,4	7,2	7,8
C	4,4	6,3	7,7	8,8	9,9	10,8
D+E+A	4,4	6,3	7,7	8,8	9,9	10,8
D+E+A+C	5,5	7,8	9,5	11	12,3	13,4

gpm

A-B-C	bar					
	1	2	3	4	5	6
D	12,1	17,1	21	24,2	27,1	29,7
E	12,1	17,1	21	24,2	27,1	29,7
A	12,1	17,1	21	24,2	27,1	29,7
C	16,7	23,7	29	33,5	37,4	41
D+E+A	16,7	23,7	29	33,5	37,4	41
D+E+A+C	20,8	29,4	36	41,6	46,5	50,9

l/min

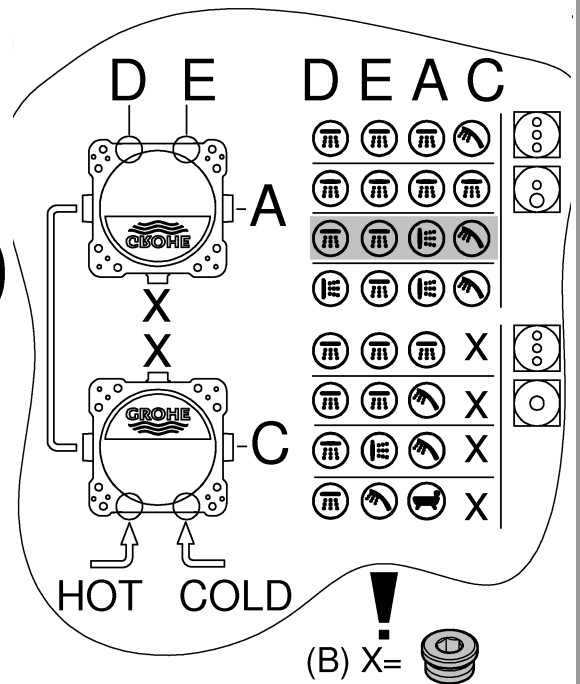
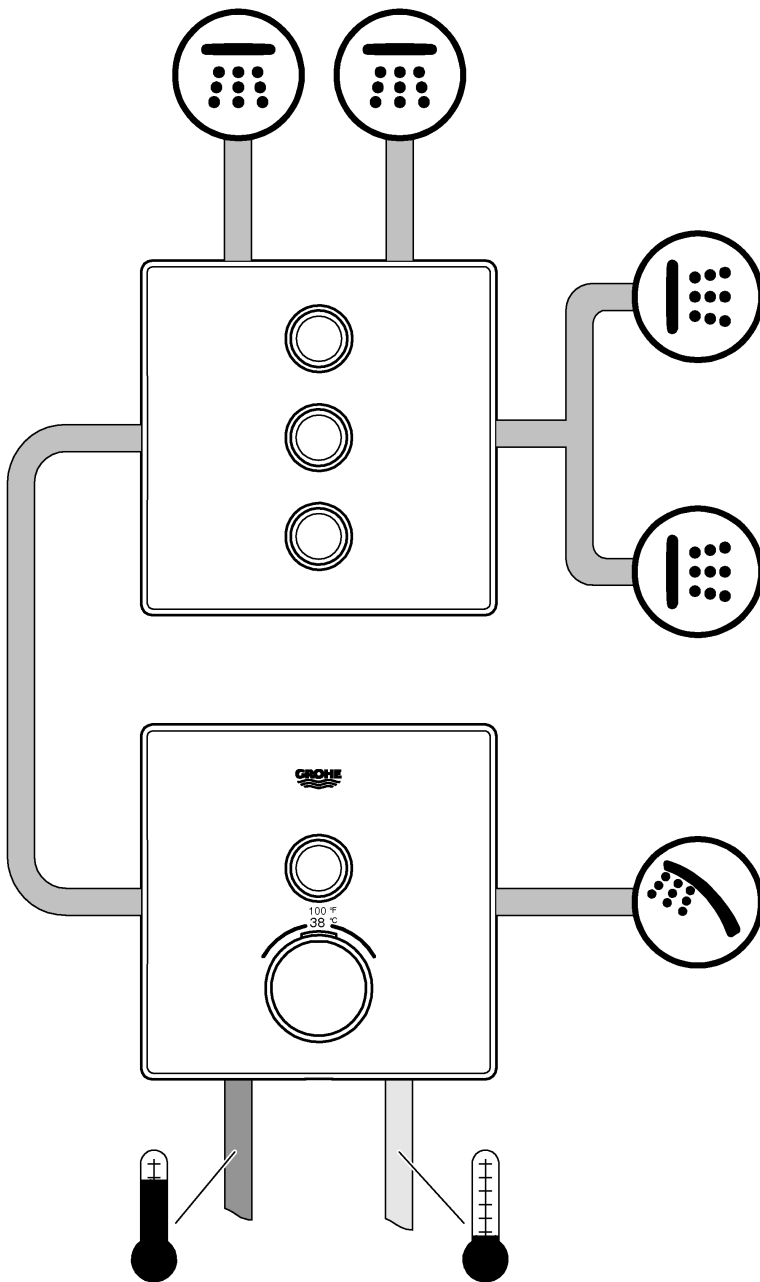

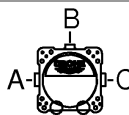

Grotherm SmartControl

	psi						gpm
	14,5	29	43,5	58	72,5	87	
D	3,2	4,5	5,5	6,4	7,2	7,8	
E	3,2	4,5	5,5	6,4	7,2	7,8	
A	3,2	4,5	5,5	6,4	7,2	7,8	
C	4,4	6,3	7,7	8,8	9,9	10,8	
D+E+A	4,4	6,3	7,7	8,8	9,9	10,8	
D+E+A+C	5,5	7,8	9,5	11	12,3	13,4	

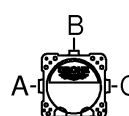
	bar						l/min
	1	2	3	4	5	6	
D	12,1	17,1	21	24,2	27,1	29,7	
E	12,1	17,1	21	24,2	27,1	29,7	
A	12,1	17,1	21	24,2	27,1	29,7	
C	16,7	23,7	29	33,5	37,4	41	
D+E+A	16,7	23,7	29	33,5	37,4	41	
D+E+A+C	20,8	29,4	36	41,6	46,5	50,9	

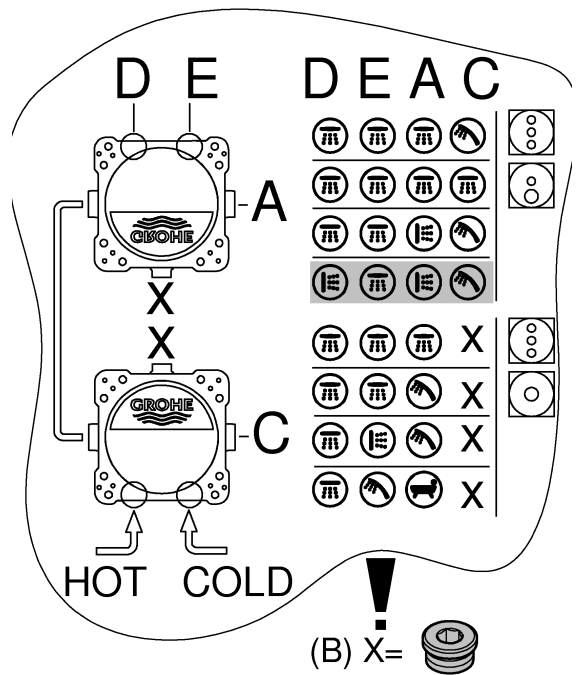
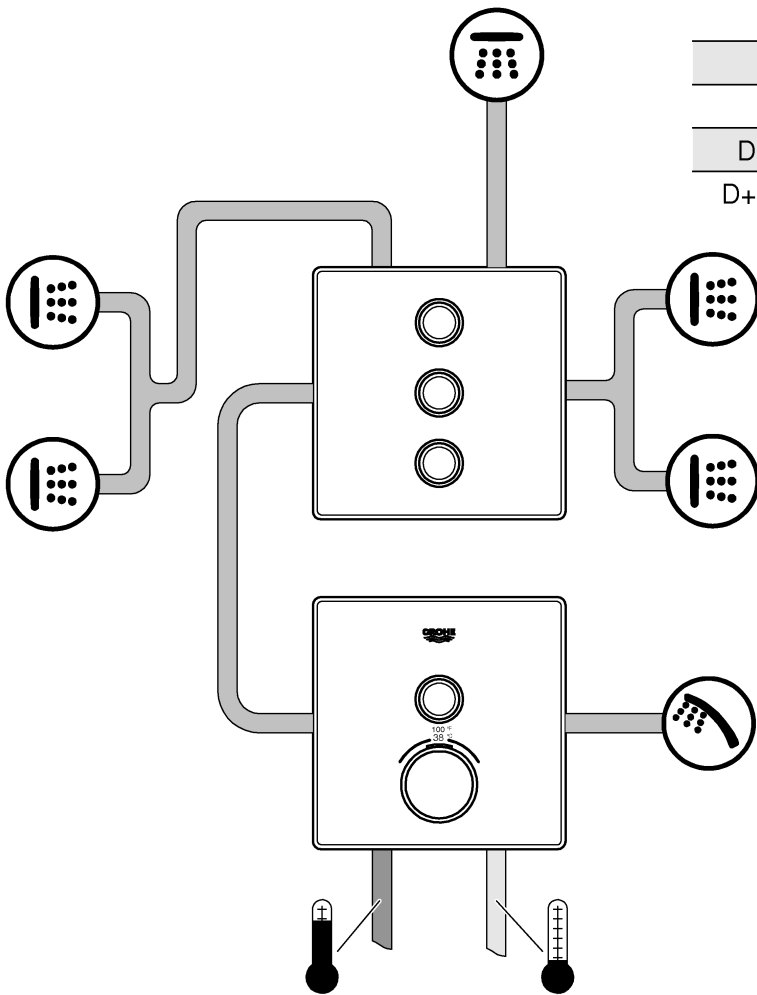

Pure Freude an Wasser

GROHE
WAVES

D

+49 571 3989 333
helpline@grohe.de

A

+43 1 68060
info-at@grohe.com

AUS

+(61) 1300 54945
grohe_australia@lixil.com

B

+32 16 230660
info.be@grohe.com

BG

+359 2 9719959
grohe-bulgaria@grohe.com

BR

0800 770 1222
falecom@grohe.com

CAU

+99 412 497 09 74
info-az@grohe.com

CDN

+1 888 6447643
info@grohe.ca

CH

+41 44 877 73 00
info@grohe.ch

CN

+86 4008811698
info.cn@grohe.com

CY

+357 22 465200
info@grome.com

CZ

+358 942 451 390
grohe-cz@grohe.com

DK

+45 44 656800
grohe@grohe.fi

E

+34 93 3368850
grohe@grohe.es

EST

+372 6616354
grohe@grohe.ee

F

+33 1 49972900
sav-fr@grohe.com

FIN

+358 942 451 390
grohe@grohe.fi

GB

+44 871 200 3414
info-uk@grohe.com

GR

+30 210 2712908
nsapountzis@ath.forthnet.gr

H

+36 1 2388045
info-hu@grohe.com

HK

+852 2969 7067
info@grohe.hk

I

+39 2 959401
info-it@grohe.com

IND

+91 1800 102 4475
customercare.in@grohe.com

IS

+354 515 4000
jonst@byko.is

J

+81 3 32989730
info@grohe.co.jp

KZ

+7 727 311 07 39
info-cac@grohe.com

LT

+372 6616354
grohe@grohe.ee

LV

+372 6616354
grohe@grohe.ee

MAL

info-malaysia@grohe.com

MX

01800 8391200
pregunta@grohe.com

N

+47 22 072070
grohe@grohe.no

NL

+31 79 3680133
vragen-nl@grohe.com

NZ

technicalenquiries@paterson
trading.co.nz

P

+351 234 529620
commercial-pt@grohe.com

PL

+48 22 5432640
biuro@grohe.com.pl

RI

0-800-1-046743
customercare-
indonesia@asia.lixil.com

RO

+40 21 2125050
info-ro@grohe.com

ROK

+82 2 1588 5903
info-singapore@grohe.com

RP

+63 2 8938681

RUS

+7 495 9819510
info@grohe.ru

S

+46 771 141314
grohe@grohe.se

SGP

+65 6311 3611
info-singapore@grohe.com

SK

+420 277 004 190
grohe-cz@grohe.com

T

+66 21681368
(Haco Group)
info@haco.co.th

TR

+90 216 441 23 70
GroheTurkey@grome.com

UA

+38 44 5375273
info-ua@grohe.com

USA

+1 800 4447643
us-customerservice@grohe.com

VN

+84 90 9694768
+84 90 9375068
info-vietnam@grohe.com

AL **BiH** **HR** **KS**

ME **MK** **SLO** **SRB**

+385 1 2911470
adria-hr@grohe.com

**Eastern Mediterranean,
Middle East - Africa
Area Sales Office:**

+357 22 465200
info@grome.com

IR **OM** **UAE** **YEM**

+971 4 3318070
grohedubai@grome.com

Far East Area Sales Office:

+65 6311 3600
info@grohe.com.sg

Latin America:

+52 818 3050626
pregunta@grohe.com

www.grohe.com

2016/09/28

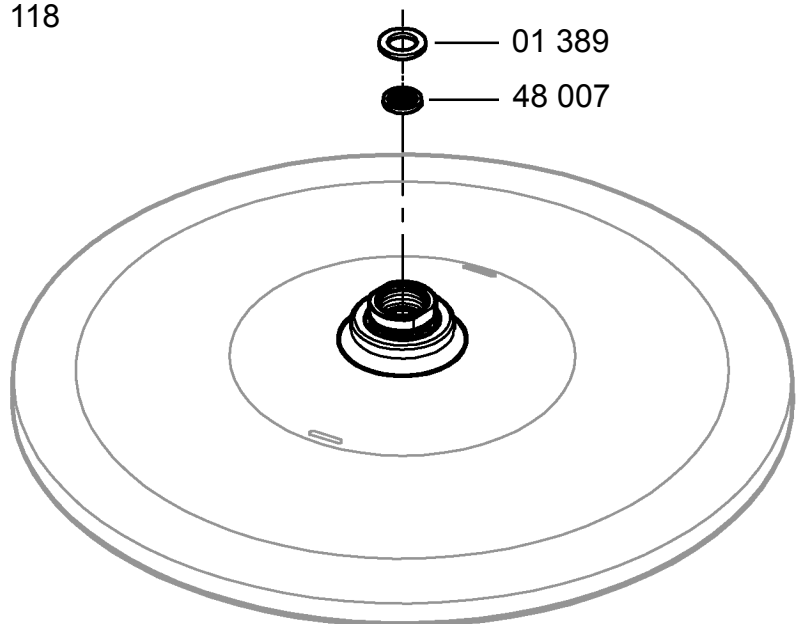
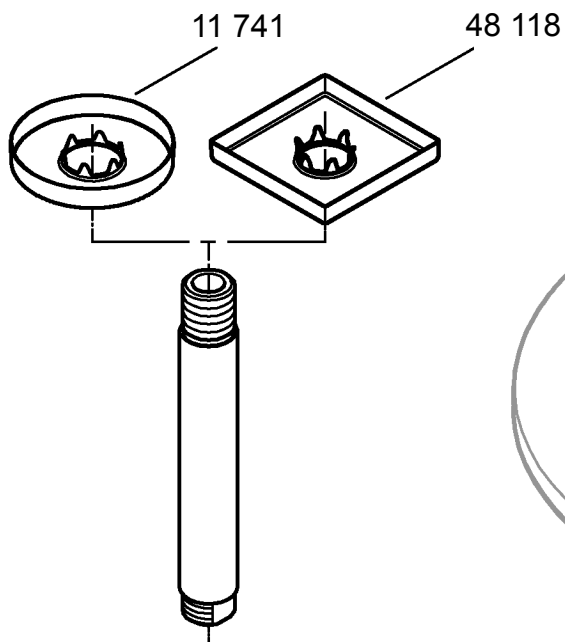
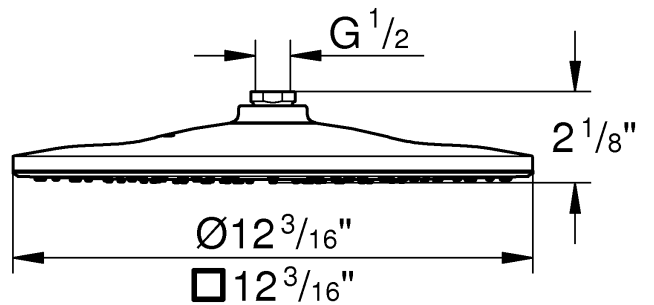
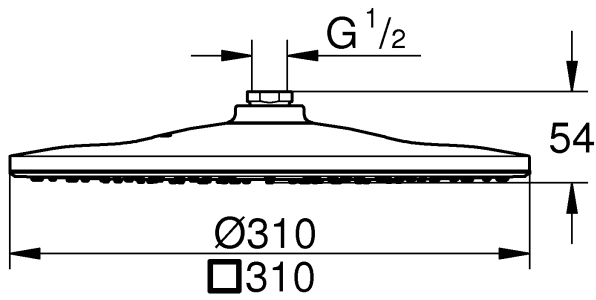
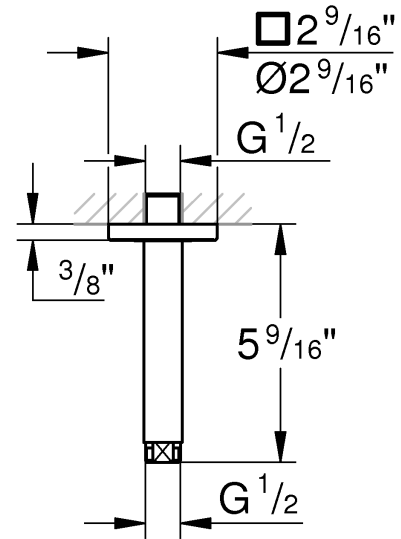
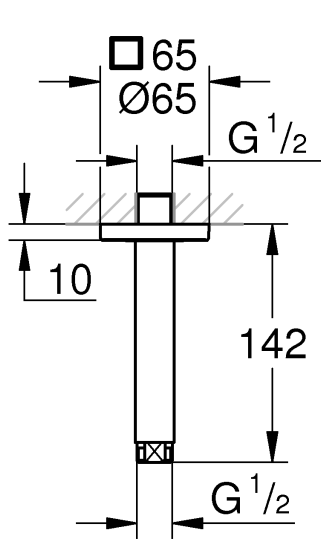

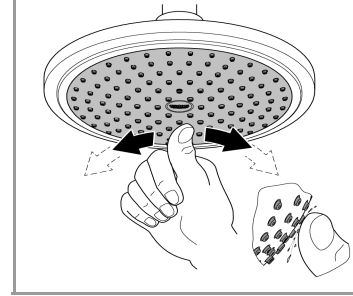
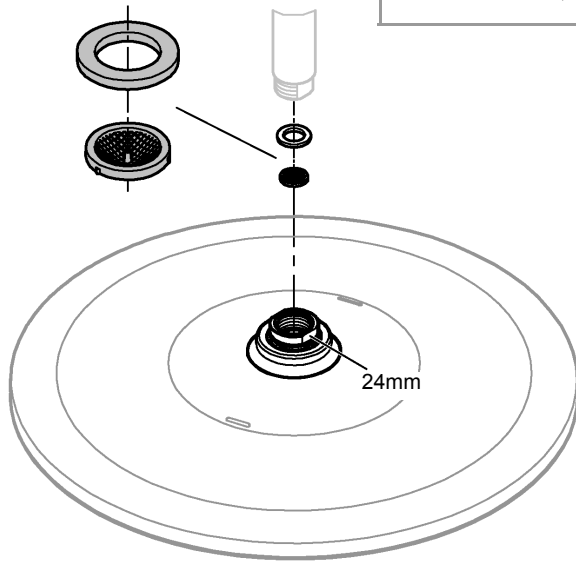
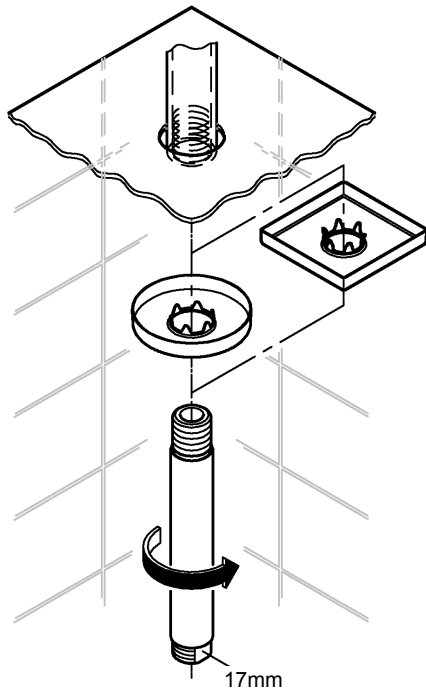

<p>D</p> <p>Bei Montage z.B. an Gipskartonwänden (keine feste Wand) muss sichergestellt sein, dass eine ausreichende Festigkeit durch eine entsprechende Verstärkung in der Wand vorhanden ist.</p>	<p>GB</p> <p>When installing e.g. on plasterboard walls (not solid walls) it must be assured that an appropriate reinforcement is in place to ensure sufficient strength.</p>	<p>F</p> <p>En cas de montage sur un support souple, une plaque de plâtre par exemple, s'assurer que des renforts ont été montés sur le mur.</p>	<p>E</p> <p>En el caso del montaje, por ejemplo en paredes de planchas de yeso (tabiques ligeros), debe asegurarse de que exista una firmeza suficiente mediante un refuerzo adecuado en la pared.</p>
<p>I</p> <p>Durante il montaggio per es. su pareti in cartongesso (parete non fissa) assicurarsi che vi sia adeguata stabilità grazie ad un rinforzo corrispondente nella parete.</p>	<p>NL</p> <p>Bij montage bijv. aan gipswanden (geen vaste wand) moet ervoor worden gezorgd, dat er voldoende stevigheid door een overeenkomstige versterking in de wand is.</p>	<p>S</p> <p>Vid montering t.ex. på gipsväggar (inte fast vägg), måste kontrolleras att tillräcklig hållfasthet garanteras av en förstärkning i väggen.</p>	<p>DK</p> <p>Ved montering på f.eks. vægge af gipsplader (ikke faste vægge) skal væggen være tilstrækkelig solid og derfor evt. forstærkes.</p>
<p>N</p> <p>Ved montering på f.eks. gipsplater (ikke fast vegg) må det kontrolleres at det er forsterkning i veggen.</p>	<p>FIN</p> <p>Kun asennus tehdään esim. kipsilevyseinini (kevytrakenteinen seinä), seinässä täytyy olla riittävä vahvike pitävän kiinnityksen varmistamiseksi.</p>	<p>PL</p> <p>W przypadku montażu na ścianach gipsowo-kartonowych (nie na ścianach stałych) należy zwiększyć wytrzymałość ściany przez wykonanie odpowiedniego wzmocnienia.</p>	<p>UAE</p> <p>عند التركيب على جدران الكرتون الجصية على سبيل المثال (جدار غير ثابت) يجب التأكد من وجود ثبات كافي عن طريق تسليح مناسب في الجدار.</p>
<p>GR</p> <p>Σε περίπτωση τοποθέτησης σε γυψοσανίδες (όχι σε σταθερή τοιχοποιία) θα πρέπει να φροντίσετε ώστε ο τοίχος να παρουσιάζει την απαιτούμενη αντοχή, π.χ. με κατάλληλη ενίσχυση.</p>	<p>CZ</p> <p>Při montáži např. na sádrokartonové stěny (není pevná stěna) se musí zkontrolovat, zda je odpovídajícím zesílením zajištěna dostatečná pevnost stěny.</p>	<p>H</p> <p>Nem szilárd falba történő szerelésnél (pl. gipszkarton fal) ügyelni kell arra, hogy a szükséges szilárdság érdekében megfelelő falba épített merevítés álljon rendelkezésre.</p>	<p>P</p> <p>Se a montagem for feita, por exemplo, a paredes de placa de gesso cartonado (paredes que não são compactas e fixas), é necessário assegurar uma suficiente fixação na parede através de um reforço.</p>
<p>TR</p> <p>Örn. alçı duvarlara (sabit duvar değil) yapılacak montajda, duvarın uygun takviyeye yeterli ölçüde sağlanma şartlarından emin olunmalıdır.</p>	<p>SK</p> <p>Pri montáži napr. na sadrokartónové stěny (nie je pevná stena) sa musí skontrolovať, či je odpovedajúcim vystužením zabezpečená dostatočná pevnosť steny.</p>	<p>SLO</p> <p>Npr. pri montaži na stene, ki niso zidane, je treba najprej preveriti, da je stena dovolj okrepljena in tako dovolj trdna.</p>	<p>HR</p> <p>Pri montaži na, primjerice, zid od gipsanog kartona (na zid koji nije čvrst), potrebno je osigurati dostatnu čvrstoću postavljanjem odgovarajućeg ojačanja u zid.</p>
<p>BG</p> <p>При монтаж напр. върху стени от гипскартон (нетвърди стени) трябва да се осигури достатъчна стабилност чрез съответно подсилване на стената.</p>	<p>EST</p> <p>Kergseinale, nt kipsseinale, paigaldamisel tuleb kõigepealt veenduda, et sein oleks vastava seinasisese tugevduse abil piisavalt tugevaks tehtud.</p>	<p>LV</p> <p>Montējot, piemēram, pie gipskartona sienām (siena nav monolīta) jāpārlicinās, lai sienā būtu pietiekoši stiprs, atbilstošs nostiprinājums.</p>	<p>LT</p> <p>Montuojant dušą, pvz., prie gipsinės (netvirtos) sienos, būtina patikrinti, ar ji pakankamai sustvirtinta.</p>
<p>RO</p> <p>La montarea pe pereți din gips carton (pereți fără rigiditate), de exemplu, trebuie să se asigure o rigiditate suficientă printr-o consolidare corespunzătoare pe perete.</p>	<p>CN</p> <p>如果在石膏墙面（而非实体墙）上安装，务必进行必要的加固以确保有足够的支撑力。</p>	<p>RUS</p> <p>При монтаже, например, на стенах из гипскартона (не обладающих прочностью) необходимо удостовериться, что достаточная прочность обеспечена за счет соответствующего усиления стены.</p>	<p>USA</p> <p>When installing e.g. on plasterboard walls (not solid walls) it must be assured that an appropriate reinforcement is in place to ensure sufficient strength.</p>



ENJOY WATER®

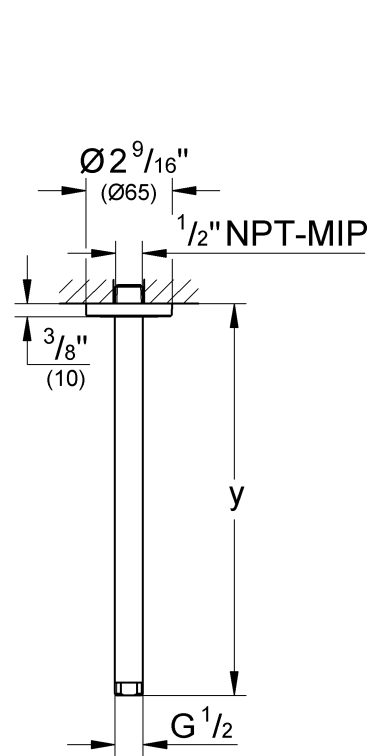
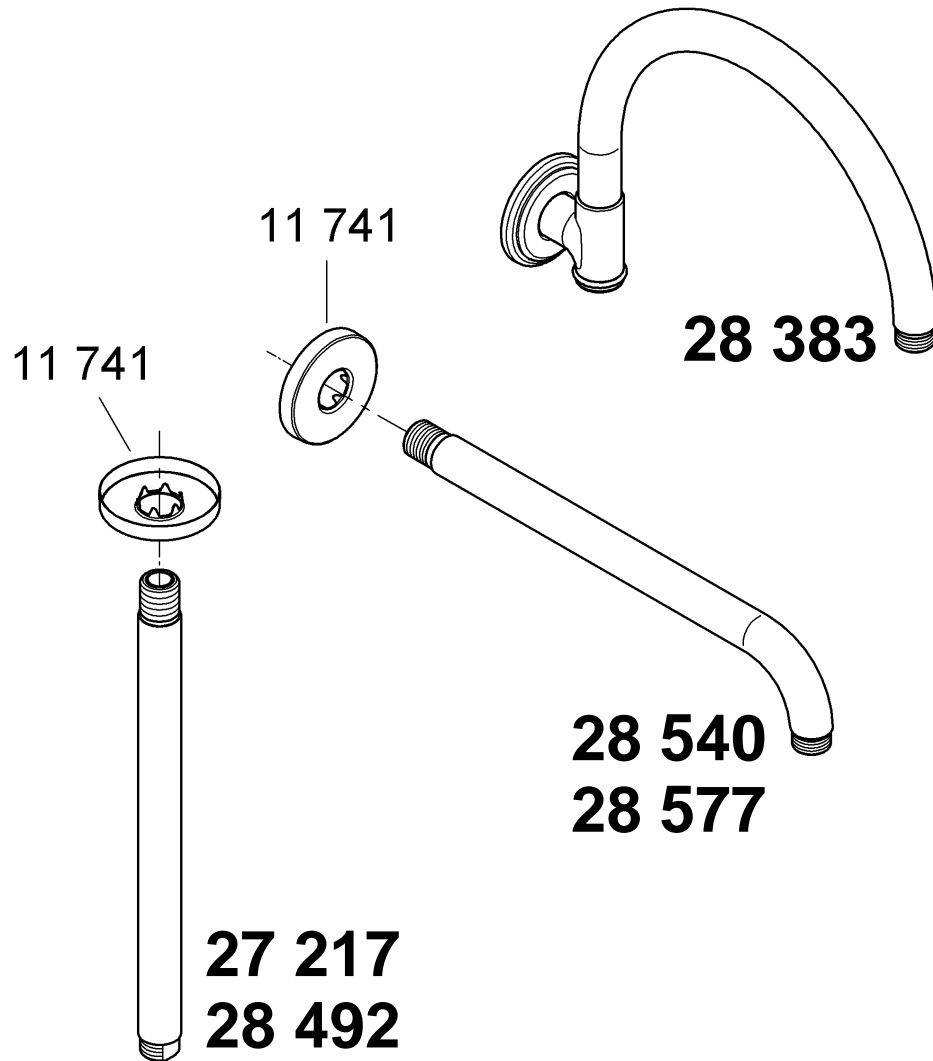

	y	y
27 217	5 3/4"	146
28 492	11 9/16"	296

27 217
28 492

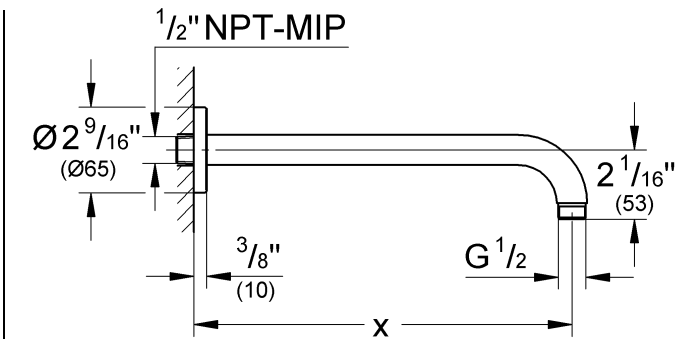

	x	x
28 577	11 5/16"	287
28 540	15 1/4"	387

28 540
28 577

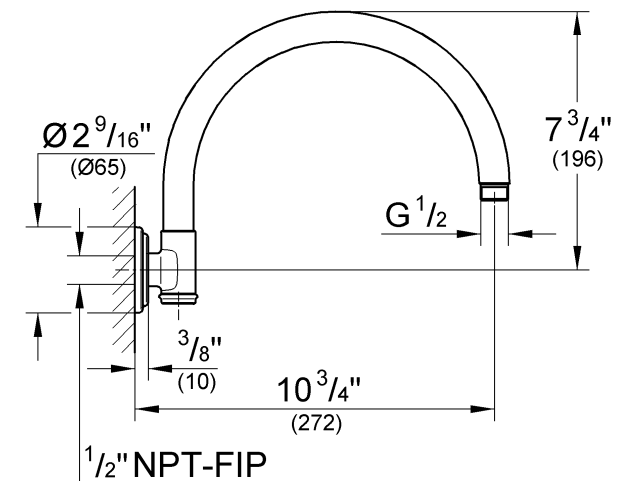

28 383



ENJOY WATER®

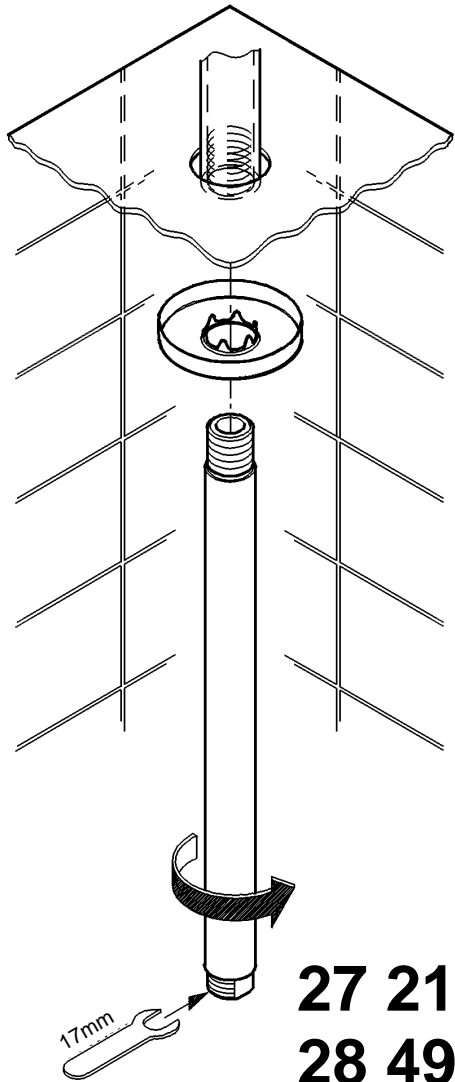

27 217
28 492

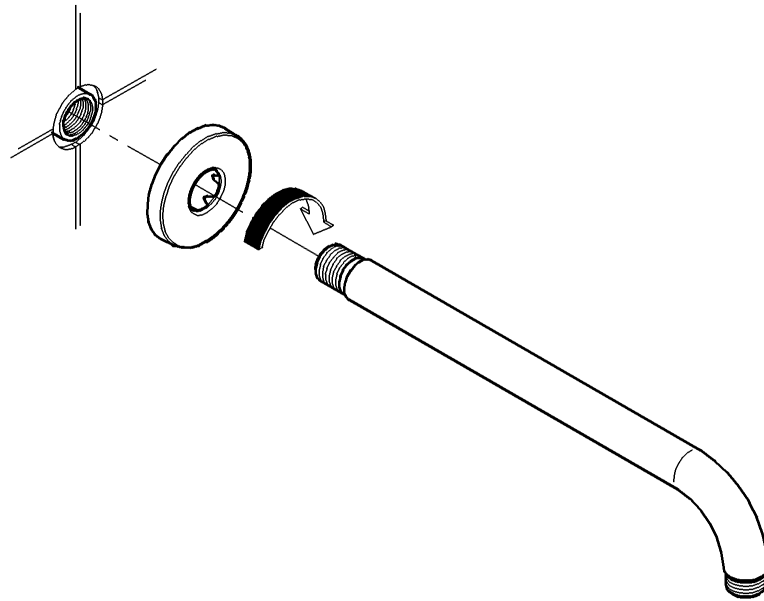

28 540
28 577

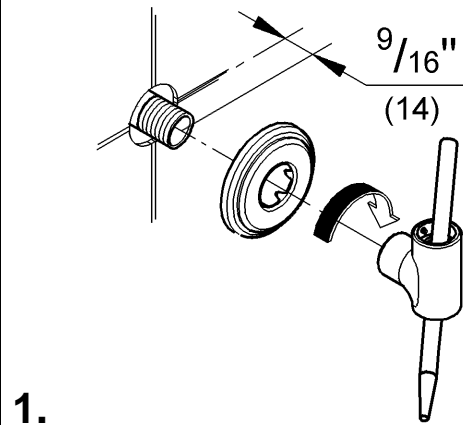

28 383

1.

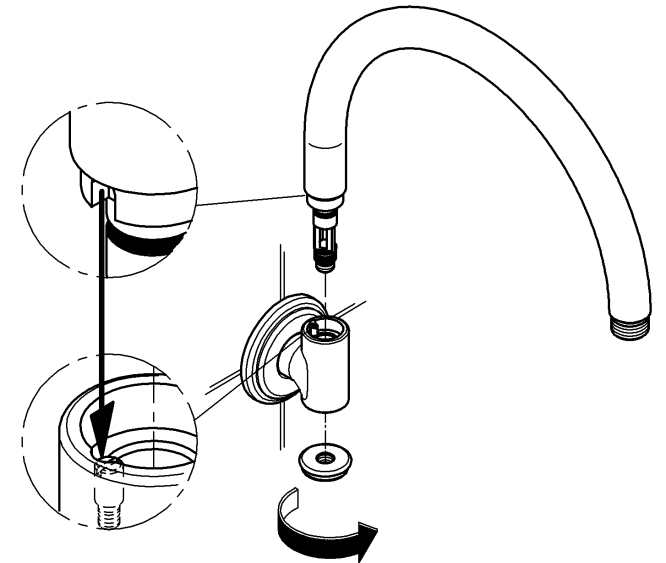

2.

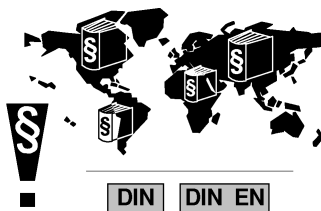

Pure Freude
an Wasser



DIN 1988 DIN EN 806

26 184

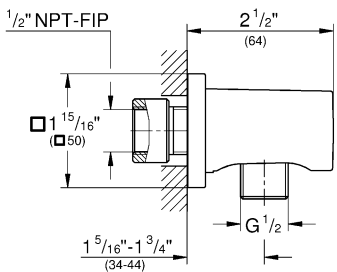

26 635

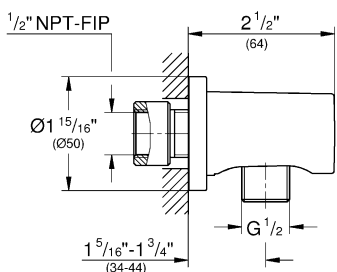

27 057

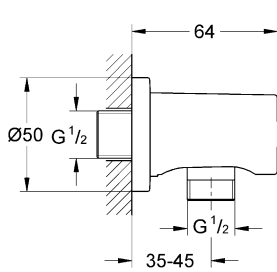

27 076

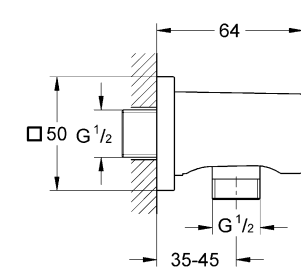

1

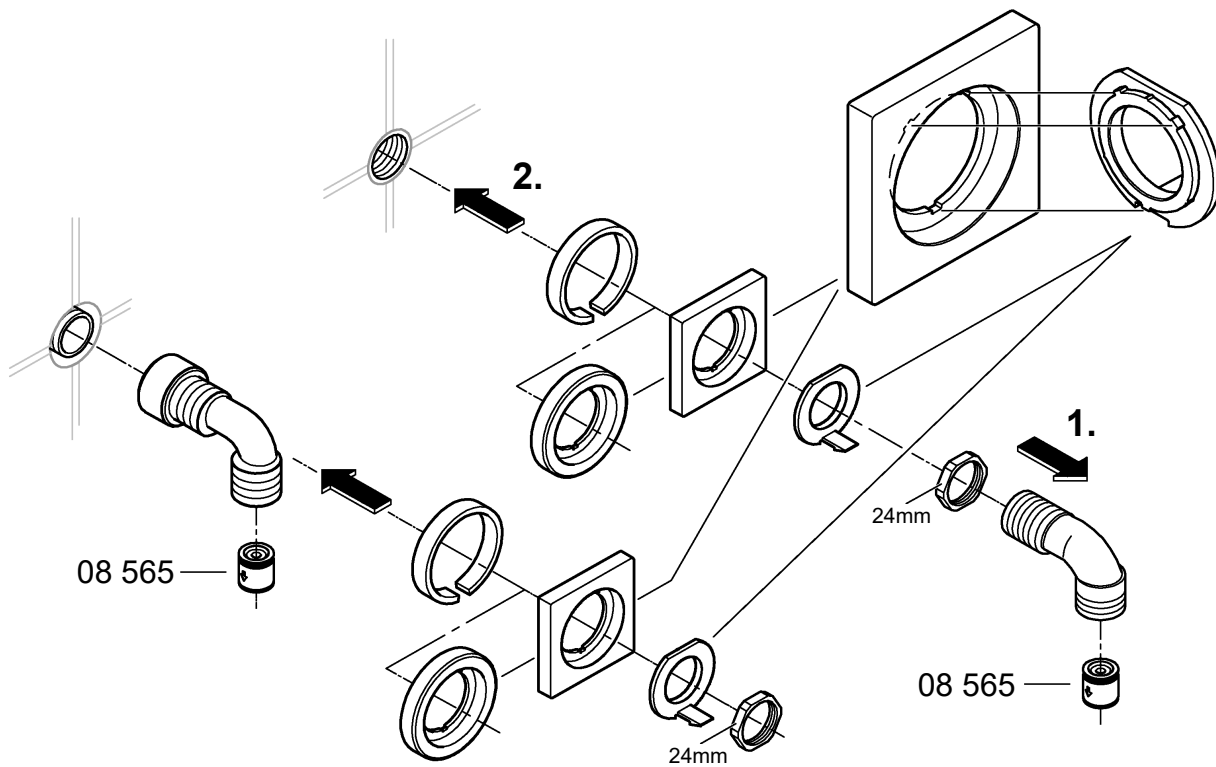

2

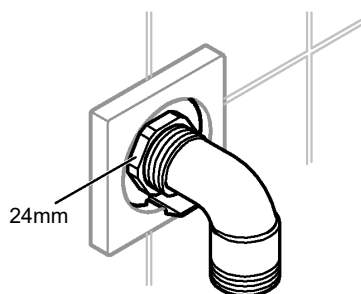

3

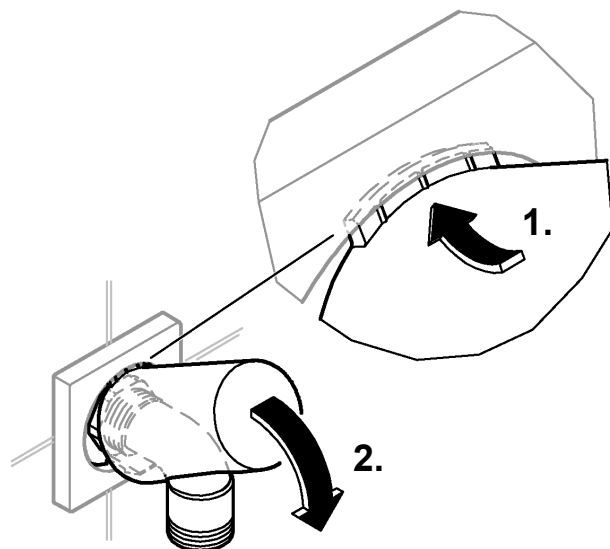



ENJOY WATER®

27 056

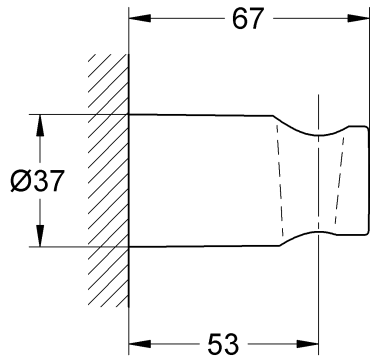

27 074

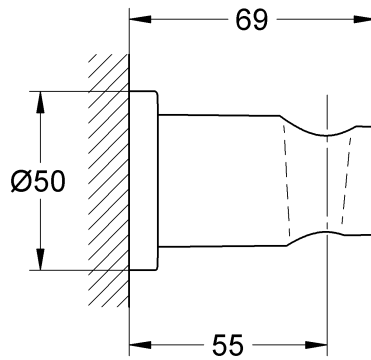

27 075

