

INSTALLATION GUIDELINES

ECO GEN Series 6kW Air-cooled Generators



TABLE OF CONTENTS

Introduction	Inside Front Cover
Read this Manual Thoroughly	IFC
Contents	1
Operation and Maintenance	1
How to Obtain Service.....	1
Safety Rules.....	1
Standards Index	3
Unpacking/Inspection.....	3
Before You Begin.....	3
Site Preparation and Generator Placement	3
Installing & Connecting Gas Lines	4
Generator Activation.....	6
Activation Chart	7
Generator Connections.....	6
Battery Installation.....	8
Operational Testing.....	8
Generator Tests Under Load	9
Checking Automatic Operation.....	9
Electrical Data	10
Installation Diagrams.....	11
Notes.....	15

INTRODUCTION

Thank you for purchasing this compact, low speed, air-cooled, engine-driven generator. It is designed for quiet operation and extended run time between service intervals.

As supplied from the factory, this generator is intended for use in off-grid applications as a part of an alternative energy system. The generator starts when the inverter/charger detects the battery pack voltage has dropped below a preset level. The generator powers the inverter, and once the voltage level of the battery rises to an acceptable level, the generator is shut down.

This unit is factory installed in an all-weather, metal enclosure that **is intended exclusively for outdoor installation**. This generator will operate using vapor withdrawn liquid propane (LP).

NOTE:

This generator is suitable for supplying typical residential loads such as Induction Motors (sump pumps, refrigerators, air conditioners, furnaces, etc.), Electronic Components (computer, monitor, TV, etc.), Lighting Loads and Microwaves.

READ THIS MANUAL THOROUGHLY

If any portion of this manual is not understood, contact the nearest Dealer for starting, operating and servicing procedures.

Throughout this publication, and on tags and decals affixed to the generator, DANGER, WARNING, CAUTION and NOTE blocks are used to alert personnel to special instructions about a particular operation that may be hazardous if performed incorrectly or carelessly. Observe them carefully. Their definitions are as follows:

▲ DANGER!

INDICATES A HAZARDOUS SITUATION OR ACTION WHICH, IF NOT AVOIDED, WILL RESULT IN DEATH OR SERIOUS INJURY.

▲ WARNING!

Indicates a hazardous situation or action which, if not avoided, could result in death or serious injury.

▲ CAUTION!

Indicates a hazardous situation or action which, if not avoided, could result in minor or moderate injury.

NOTE:

Notes contain additional information important to a procedure and will be found within the regular text body of this manual.

These safety warnings cannot eliminate the hazards that they indicate. Common sense and strict compliance with the special instructions while performing the action or service are essential to preventing accidents.

Four commonly used safety symbols accompany the **DANGER**, **WARNING** and **CAUTION** blocks. The type of information each indicates is as follows:

▲ This symbol points out important safety information that, if not followed, could endanger personal safety and/or property of others.

 This symbol points out potential explosion hazard.

 This symbol points out potential fire hazard.

 This symbol points out potential electrical shock hazard.

The operator is responsible for proper and safe use of the equipment. The manufacturer strongly recommends that the operator read this *Owner's Manual* and thoroughly understand all instructions before using this equipment. The manufacturer also strongly recommends instructing other users to properly start and operate the unit. This prepares them if they need to operate the equipment in an emergency.

CONTENTS

This manual contains pertinent owner's information for a 6kW LP, GT-530 engine.

OPERATION AND MAINTENANCE

It is the operator's responsibility to perform all safety checks, to make sure that all maintenance for safe operation is performed promptly, and to have the equipment checked periodically by a Dealer. Normal maintenance service and replacement of parts are the responsibility of the owner/operator and, as such, are not considered defects in materials or workmanship within the terms of the warranty. Individual operating habits and usage contribute to the need for maintenance service.

Proper maintenance and care of the generator ensures a minimum number of problems and keep operating expenses at a minimum. See a Dealer for service aids and accessories.

HOW TO OBTAIN SERVICE

When the generator requires servicing or repairs, contact a Dealer for assistance. Service technicians are factory-trained and are capable of handling all service needs.

When contacting a Dealer about parts and service, always supply the complete model number and serial number of the unit as given on its data decal, which is located on the generator. See section "The Generator" for decal location.

Model No. _____ Serial No. _____

SAFETY RULES

⚠ WARNING!

⚠ Save These Instructions – The manufacturer suggests that these rules for safe operation be copied and posted near the unit's installation site. Safety should be stressed to all operators and potential operators of this equipment.

Study these SAFETY RULES carefully before installing, operating or servicing this equipment. Become familiar with this *Owner's Manual* and with the unit. The generator can operate safely, efficiently and reliably only if it is properly installed, operated and maintained. Many accidents are caused by failing to follow simple and fundamental rules or precautions.

The manufacturer cannot anticipate every possible circumstance that might involve a hazard. The warnings in this manual, and on tags and decals affixed to the unit are, therefore, not all-inclusive. If using a procedure, work method or operating technique the manufacturer does not specifically recommend, ensure that it is safe for others. Also make sure the procedure, work method or operating technique utilized does not render the generator unsafe.

⚠ DANGER!

⚠ Despite the safe design of this generator, operating this equipment imprudently, neglecting its maintenance or being careless can cause possible injury or death. Permit only responsible and capable persons to install, operate and maintain this equipment.

⚠ Potentially lethal voltages are generated by these machines. Ensure all steps are taken to render the machine safe before attempting to work on the generator.

⚠ Parts of the generator are rotating and/or hot during operation. Exercise care near running generators.

⚠ Installation must always comply with applicable codes, standards, laws and regulations.

⚠ A running generator gives off carbon monoxide, and odorless, colorless poison gas. Breathing in carbon monoxide can cause headaches, fatigue, dizziness, nausea, vomiting, confusion, fainting, seizures or death.

CALIFORNIA PROPOSITION 65 WARNING

Engine exhaust and some of its constituents are known to the State of California to cause cancer, birth defects and other reproductive harm.

CALIFORNIA PROPOSITION 65 WARNING

This product contains or emits chemicals known to the State of California to cause cancer, birth defects and other reproductive harm.

GENERAL HAZARDS

- For safety reasons, the manufacturer recommends that this equipment be installed, serviced and repaired by a Service Dealer or other competent, qualified electrician or installation technician who is familiar with applicable codes, standards and regulations. The operator also must comply with all such codes, standards and regulations.
- The engine exhaust fumes contain carbon monoxide, which can be DEADLY. This dangerous gas, if breathed in sufficient concentrations, can cause unconsciousness or even death. Do NOT alter or add to the exhaust system or do anything that might render the system unsafe or in noncompliance with applicable codes and standards.
- Install a battery operated carbon monoxide alarm indoors, according to manufacturer's instructions/recommendations.
- Adequate, unobstructed flow of cooling and ventilating air is critical to correct generator operation. Do not alter the installation or permit even partial blockage of ventilation provisions, as this can seriously affect safe operation of the generator. **The generator MUST be installed and operated outdoors only.**
- Keep hands, feet, clothing, etc., away from drive belts, fans, and other moving or hot parts. Never remove any drive belt or fan guard while the unit is operating.
- When working on this equipment, remain alert at all times. Never work on the equipment when physically or mentally fatigued.
- Inspect the generator regularly, and contact the nearest Dealer for parts needing repair or replacement.
- Before performing any maintenance on the generator, disconnect its battery cables to prevent accidental start up. Disconnect the cable from the battery post indicated by a NEGATIVE, NEG or (-) first, then remove the POSITIVE, POS or (+) cable. When reconnecting the cables, connect the POSITIVE cable first, the NEGATIVE cable last.
- Never use the generator or any of its parts as a step. Stepping on the unit can stress and break parts, and may result in dangerous operating conditions from leaking exhaust gases, fuel leakage, oil leakage, etc.

ELECTRICAL HAZARDS

- All generators covered by this manual produce dangerous electrical voltages and can cause fatal electrical shock. Utility power delivers extremely high and dangerous voltages to the transfer switch as does the standby generator when it is in operation. Avoid contact with bare wires, terminals, connections, etc., while the unit is running. Ensure all appropriate covers, guards and barriers are in place, secured and/or locked before operating the generator. If work must be done around an operating unit, stand on an insulated, dry surface to reduce shock hazard.
- Do not handle any kind of electrical device while standing in water, while barefoot, or while hands or feet are wet. **DANGEROUS ELECTRICAL SHOCK MAY RESULT.**
- The National Electrical Code (NEC) requires the frame and external electrically conductive parts of the generator to be connected to an approved earth ground. Local electrical codes also may require proper grounding of the generator electrical system.

- After installing this home standby electrical system, the generator may crank and start at any time without warning. When this occurs, load circuits are transferred to the STANDBY (generator) power source. To prevent possible injury if such a start and transfer occur, always set the generator's AUTO/OFF/MANUAL switch to its OFF position before working on equipment and remove the 7.5A fuse from the generator control panel.
- In case of accident caused by electric shock, immediately shut down the source of electrical power. If this is not possible, attempt to free the victim from the live conductor. **AVOID DIRECT CONTACT WITH THE VICTIM.** Use a nonconducting implement, such as a dry rope or board, to free the victim from the live conductor. If the victim is unconscious, apply first aid and get immediate medical help.
- Never wear jewelry when working on this equipment. Jewelry can conduct electricity resulting in electric shock, or may get caught in moving components causing injury.

FIRE HAZARDS

- For fire safety, the generator must be installed and maintained properly. **Installation must always comply with applicable codes, standards, laws and regulations.** Adhere strictly to local, state and national electrical and building codes. Comply with regulations the Occupational Safety and Health Administration (OSHA) has established. Also, ensure that the generator is installed in accordance with the manufacturer's instructions and recommendations. Following proper installation, do nothing that might alter a safe installation and render the unit in noncompliance with the aforementioned codes, standards, laws and regulations.
- Keep a fire extinguisher near the generator at all times. Extinguishers rated "ABC" by the National Fire Protection Association are appropriate for use on the standby electric system. Keep the extinguisher properly charged and be familiar with its use. Consult the local fire department with any questions pertaining to fire extinguishers.

EXPLOSION HAZARDS

- Do not smoke around the generator. Wipe up any fuel or oil spills immediately. Ensure that no combustible materials are left in the generator compartment, or on or near the generator, as FIRE or EXPLOSION may result. Keep the area surrounding the generator clean and free from debris.
- Gaseous fluids such as natural gas and liquid propane (LP) gas are extremely EXPLOSIVE. Install the fuel supply system according to applicable fuel-gas codes. Before placing the home standby electric system into service, fuel system lines must be properly purged and leak tested according to applicable code. After installation, inspect the fuel system periodically for leaks. No leakage is permitted.

STANDARDS INDEX

In the absence of pertinent standards, codes, regulations and laws, the published information listed below may be used as installation guide for this equipment.

1. NFPA No. 37, STATIONARY COMBUSTION ENGINES AND GAS TURBINES, available from the National Fire Protection Association, 470 Atlantic Avenue, Boston, MA 02210.
2. NFPA No. 76A, ESSENTIAL ELECTRICAL SYSTEMS FOR HEALTH CARE FACILITIES, available same as Item 1.
3. NFPA No. 54, NATIONAL FUEL GAS CODE, available same as Item 1.
4. NFPA No. 58, AMERICAN NATIONAL STANDARD FOR STORAGE AND HANDLING OF LIQUEFIED PETROLEUM GAS, available same as Item 1.
5. NFPA No. 70, NFPA HANDBOOK OF NATIONAL ELECTRIC CODE, available same as Item 1.
6. Article X, NATIONAL BUILDING CODE, available from the American Insurance Association, 85 John Street, New York, N.Y. 10038.
7. AGRICULTURAL WIRING HANDBOOK, available from the Food and Energy Council, 909 University Avenue, Columbia, MO 65201.
8. ASAE EP-3634, INSTALLATION AND MAINTENANCE OF FARM STANDBY ELECTRICAL SYSTEMS, available from the American Society of Agricultural Engineers, 2950 Niles Road, St. Joseph, MI 49085.
9. NFPA No. 30, FLAMMABLE AND COMBUSTIBLE LIQUIDS CODE, available same as Item 1.

⚠ DANGER!

⚠ Only qualified electricians or contractors should attempt such installations, which must comply strictly with applicable codes, standards and regulations.

UNPACKING/INSPECTION

After unpacking, carefully inspect the contents for damage.

- This standby generator set is ready for installation with a factory supplied and pre-mounted base pad and has a weather protective enclosure that is intended for **outdoor installation only**.

If any loss or damage is noted at time of delivery, have the person(s) making the delivery note all damage on the freight bill or affix their signature under the consignor's memo of loss or damage.

If a loss or damage is noted after delivery, separate the damaged materials and contact the carrier for claim procedures.

"Concealed damage" is understood to mean damage to the contents of a package that is not in evidence at the time of delivery, but is discovered later.

To properly open the roof, press down on the center top lip and release the latch. If pressure is not applied from the top, the roof may appear stuck. Always verify that the side lock is unlocked before attempting to lift the roof.

BEFORE YOU BEGIN

Contact the local inspector or City Hall to be aware of all federal, state and local codes that could impact the installation. Secure all required permits before starting the job.

Carefully read and follow all of the procedures and safety precautions detailed in the installation guide. If any portion of the installation manual, technical manual or other factory-supplied documents is not completely understood, contact a dealer for assistance.

Fully comply with all relevant NEC, NFPA and OSHA standards as well as all federal, state and local building and electric codes. As with any generator, this unit must be installed in accordance with current NFPA 37 and NFPA 70 standards as well as any other federal, state, and local codes for minimum distances from other structures.

SITE PREPARATION AND GENERATOR PLACEMENT



1. Locate the mounting area as close as possible to the inverter system and fuel supply. Leave adequate room around the area for service access (check local code), and place high enough to keep rising water from reaching the generator. Choose an open space that will provide adequate and unobstructed airflow (see the "Location" section in the Owner's Manual).



2. Place the unit so air vents won't become clogged with leaves, grass, snow or debris. Make sure exhaust fumes will not enter the building through eaves, windows, ventilation fans or other air intakes.

Dig a rectangular area approximately five inches deep and about six inches longer and wider than the footprint of the generator. Cover with polyurethane film and fill with pea gravel or crushed stone. Compact and level the stone. A concrete pad can be poured if desired.

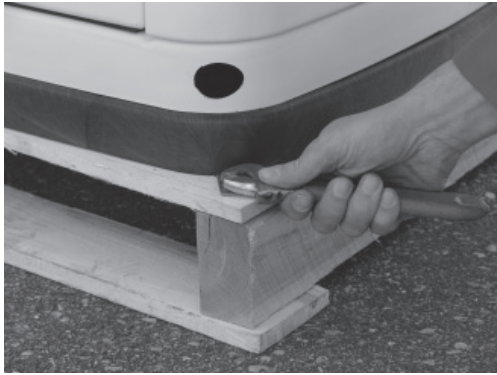

3. Inspect the generator for shipping damage and if necessary, file a claim with the shipper. Remove the bands holding the generator to the wooden pallet.



4. Make sure the lifting equipment to be used has sufficient capacity to safely handle the weight of the generator. Use nylon lifting straps and connect them to the lifting eyes on each corner of the base frame to avoid damaging the enclosure.



5. Set the generator onto the pad so that the gravel bed extends several inches beyond the generator on all sides. Make sure the generator is level within 1/2 inch.



6. Connect an approved ground strap to the grounding lug on the base frame and to an approved earth ground or grounding rod as specified by local regulations. All inverter manufacturers require grounding the generator.
7. Check the engine oil and, if necessary, add enough of the recommended oil to bring the level up to the FULL mark on the dipstick. Be careful not to overfill the crankcase.

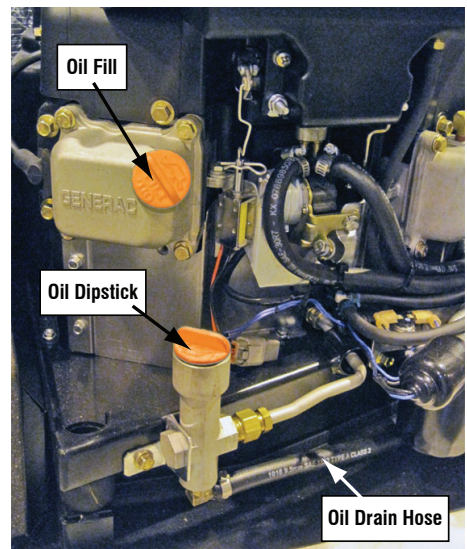

INSTALLING & CONNECTING GAS LINES

1. LP Vapor is a highly volatile substance, so strict adherence to all safety procedures, codes, standards and regulations is essential. Gas line connections should be made by a certified plumber familiar with local codes. Always use AGA-approved gas pipe and a quality pipe sealant or joint compound. Verify the capacity of the LP tank in regards to providing sufficient fuel for both the generator and other operating appliances.



2. Most applications will require an external manual shutoff valve on the fuel line.



3. Where the gas line is to enter the generator, install a T-fitting to allow for gas pressure monitoring. On one opening of the fitting install a 1/4" NPT nipple and threaded plug. In some cases a sediment trap may also be installed.



4. When connecting the gas line to the generator, use the provided section of UL Listed or AGA-approved flexible fuel line in accordance with local regulations. The purpose of the flexible fuel line is to ensure that vibration from the generator does not cause a gas leak at one of the connection points, so it's important that the line be installed with as few bends as possible.



5. Never bend the flexible fuel line to avoid using an elbow. Bending the flexible line decreases its ability to absorb vibrations and defeats its purpose as well as constricts the actual fuel flow.



6. After checking for leaks, check the gas pressure at the T-fitting installed earlier to make sure there's enough pressure for proper generator operation. The local gas supplier is responsible for ensuring adequate pressure, so if the pressure is too low, or if it's greater than 14 inches of water column, contact the gas supplier.



7. When finished checking the gas pressure, close the manual shutoff valve.

GENERATOR ACTIVATION

When battery power is applied to the generator during the installation process, the controller will light up. However, the generator still needs to be activated before it will automatically run in the event of a power outage.

Activating the generator is a simple one time process that is guided by the controller screen prompts. Once the product is activated, the controller screen will not prompt you again, even if you disconnect the generator battery.

After obtaining your activation code, please complete the following steps at the generator's control panel in the **Activation Chart** (shown on the following page).



5. Feed the wires through the back of the generator and secure the conduit with the lock nut.
6. Run the power leads through the strain relief provided.

GENERATOR CONNECTIONS



It is highly recommended that an additional single pole, single throw switch be installed near the inverter system to verify the generator start function. Sometimes an inverter can have the setting improperly adjusted resulting in a perceived generator no-start condition. This switch would allow for testing of the 2-wire start function on the generator.

1. Pop the metal cover circle off the back of the generator enclosure.
2. Remove the metal cover from the controller. Locate the plastic cover that protects the wire connection (towards the rear of the controller compartment).
3. Remove the plastic cover to access the wire connections.

This system is equipped with a 2-wire start to enable easy connection with the inverter system. The recommended wire sizes are:

MAXIMUM WIRE LENGTH	RECOMMENDED WIRE SIZE
460 feet (140m)	No. 18 AWG.
461 to 730 feet (223m)	No. 16 AWG.
731 to 1,160 feet (354m)	No. 14 AWG.
1,161 to 1,850 feet (565m)	No. 12 AWG.

4. Remove the two screws securing the connection area cover, and remove the cover.



7. The circuit breaker is attached to the exterior access panel.





8. Remove the plastic plugs inside the main breaker access area to allow connection of the power leads to the circuit breaker.

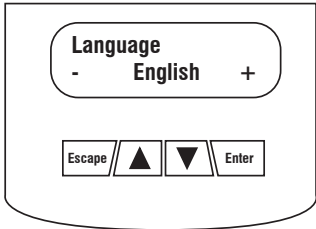
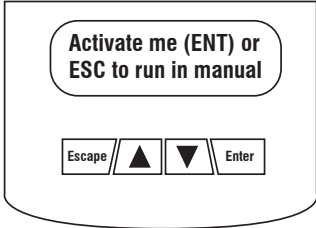

9. Now connect the power lead to the circuit breaker.

ACTIVATION CHART

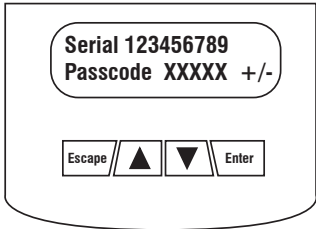
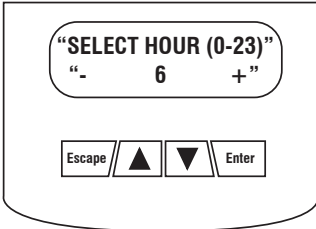
CHOOSE LANGUAGE		TROUBLESHOOTING
<p>Display Reads:</p> 	<p>Use ARROW keys to scroll to desired language. Press ENTER to select.</p>	<p>If the wrong language is chosen, it can be changed later using the “edit” menu.</p>
<p>Display Reads:</p> 	<p>Press ENTER to begin the activation process.</p>	<p>If ESCAPE is pressed instead of ENTER, your generator will only run in manual mode (for test purposes) and NOT ACTIVATED will be displayed. You will need to reconnect the battery and begin with Step 1.</p>
<p>Display Reads:</p> 	<p>If you do not have your activation code, go to www.activategen.com or call 1-888-9ACTIVATE (922-8482).</p> <p>If you already have your activation code, wait 3-5 seconds for the next display.</p>	
ENTER ACTIVATION CODE (Passcode)		TROUBLESHOOTING
<p>Display Reads:</p> 	<p>Use ARROW keys to scroll and find the first number of your Activation Code.</p> <p>Press ENTER to select.</p> <p>Repeat this step until all digits have been entered.</p> <p>Use ESCAPE to correct previous digits.</p>	
<p>Display Reads:</p> 	<p>Activation is complete when all digits are entered above and your screen shows this display.</p> <p>Follow the controller prompts to continue setting the time function. Refer to your Owner’s Manual with questions.</p>	<p>What happens if “Wrong Passcode Try Again” appears?</p> <p>Reenter the activation code. If a second attempt is unsuccessful, check the number against the code given on activategen.com. If it is correct and the generator will not accept it, contact 1-888-9ACTIVATE (922-8482).</p>

10. Connect the green equipment ground wire to the ground bus bar and torque to 35 inch lbs. The torque values are:
 - 10-14 AWG = 35 in/lbs
 - 8 AWG = 40 in/lbs
 - 4-6 AWG = 45 in/lbs

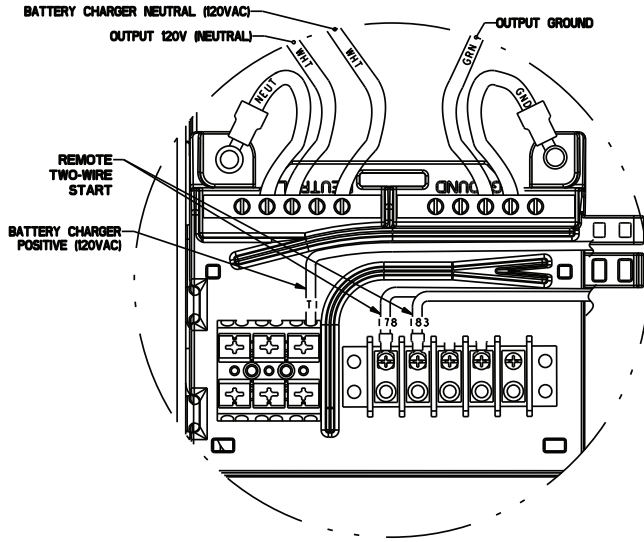

11. Connect the white neutral wire to the neutral bus bar and torque to 35 inch lbs. The torque values are:
 - 10-14 AWG = 35 in/lbs
 - 8 AWG = 40 in/lbs
 - 4-6 AWG = 45 in/lbs
12. Connect the control wires to the correct terminals. The terminals are clearly marked 178, 183 and T1. Connect battery charger neutral (120 VAC) to neutral Bus.

NOTE:

In order to maintain separation of circuits, the DC control wires must be separated from the AC control wires. A piece of fiberglass sleeving has been provided in the manual kit to achieve this. Slide the sleeving over the AC wires OR the DC wires, but not both, from the wire landing area to the outside of the generator. Use the cable tie locations to hold the sleeving in place.

12. An improperly connected control wire can damage the generator control board. It is highly recommended that an additional switch be installed in-line of the generator output (HOT) wire at/before the inverter/energy management system. The installer must comply to local codes and regulations regarding correct rating. This will provide a safety disconnect at the inverter.

BATTERY INSTALLATION



1. Before purchasing a battery for the generator, refer to the Owner's Manual for the recommended battery.
 - Group 26R, 12 Volt, 525cca minimum



2. Follow all of the procedures and safety precautions in the generator Owner's Manual when installing the battery. Verify the switch is in the off position. When preparing for operational testing, DO NOT connect the battery until all electrical connections are complete.

OPERATIONAL TESTING

Verify that all wiring connections at the Alternative Power Management System are correct. Refer to the system manufacturer's installation manuals for specific instructions. The system manufacturer's instructions should always be followed when testing the operation of the off-grid system.

1. Verify power is being supplied to the generator battery charger. Verify that 120 VAC from T1 terminal to the neutral bar in the generator customer connect.
2. Turn OFF or open the main Circuit Breaker and select the OFF position of the AUTO/OFF/MANUAL switch on the Nexus controller.

The next test is to verify that the generator operates properly under no load.

3. Turn the main Circuit Breaker to the OFF or Open position.
4. Set the AUTO/OFF/MANUAL switch to the MANUAL position. The engine should crank and start. Allow the engine to warm up for about 5 minutes
5. Once the engine is warm, verify that you have 60 Hz and between 120 to 125 VAC at the generator's main Circuit Breaker.
6. Set the AUTO/OFF/MANUAL switch into the Off position to shut the generator down.

NOTE:

Even if the generator is running smoothly at this point, a drop in gas pressure indicates that the supply is barely adequate to supply the generator's needs. Changes in the generator load, or additional gas demand by other appliances may affect the generator's performance. Verify gas pressure and pipe sizing. Unhook the manometer and reinstall the port plug.

GENERATOR TESTS UNDER LOAD

1. Test the generator with electrical loads applied, start by placing all of the breakers on the Alternative Power Management System into the OFF or open position.
2. The disconnect switch recommended to be installed at the generator input to the Alternative Power Management System should be switched to OFF or Open position.
3. Place the main Circuit Breaker on the generator in the ON or closed position.
4. Set the AUTO/OFF/MANUAL switch to MANUAL. The generator should crank and start immediately. Let the engine stabilize and warm up for a few minutes.
5. Check voltage and frequency at the disconnect switch installed between the generator and the Alternative Power Management System.
6. If the appropriate voltage and frequency are present, close the disconnect switch.
7. Check voltage and frequency at the Alternative Power Management System by closing the breakers one at a time. (if applicable)
8. Let the generator run under load for 20-30 minutes while listening for any unusual noises, vibration or other indications of abnormal operation such as oil leaks or overheating.



9. With the generator carrying the entire priority load, recheck gas pressure to verify that it is at the same level it was before the generator was started.
10. When completed, open the disconnect switch and allow the generator to run at no load.
11. Place the AUTO/OFF/MANUAL switch into the OFF position. The generator will shut down. Return to the disconnect switch and place it in the ON or closed position.

CHECKING AUTOMATIC OPERATION

1. To check the automatic operation, place the AUTO/OFF/ON switch to the AUTO position.
2. Verify the remote two-wire start test switch that's installed near the Alternative Power Management System is set to the ON or closed position. This will cause the generator to start automatically.
3. With the generator running and powering loads, set the remote two-wire start test switch to the OFF or open position. In approximately one minute the generator will automatically shut down.

6kW ECO GEN
Oil Make-Up System
Not To Scale

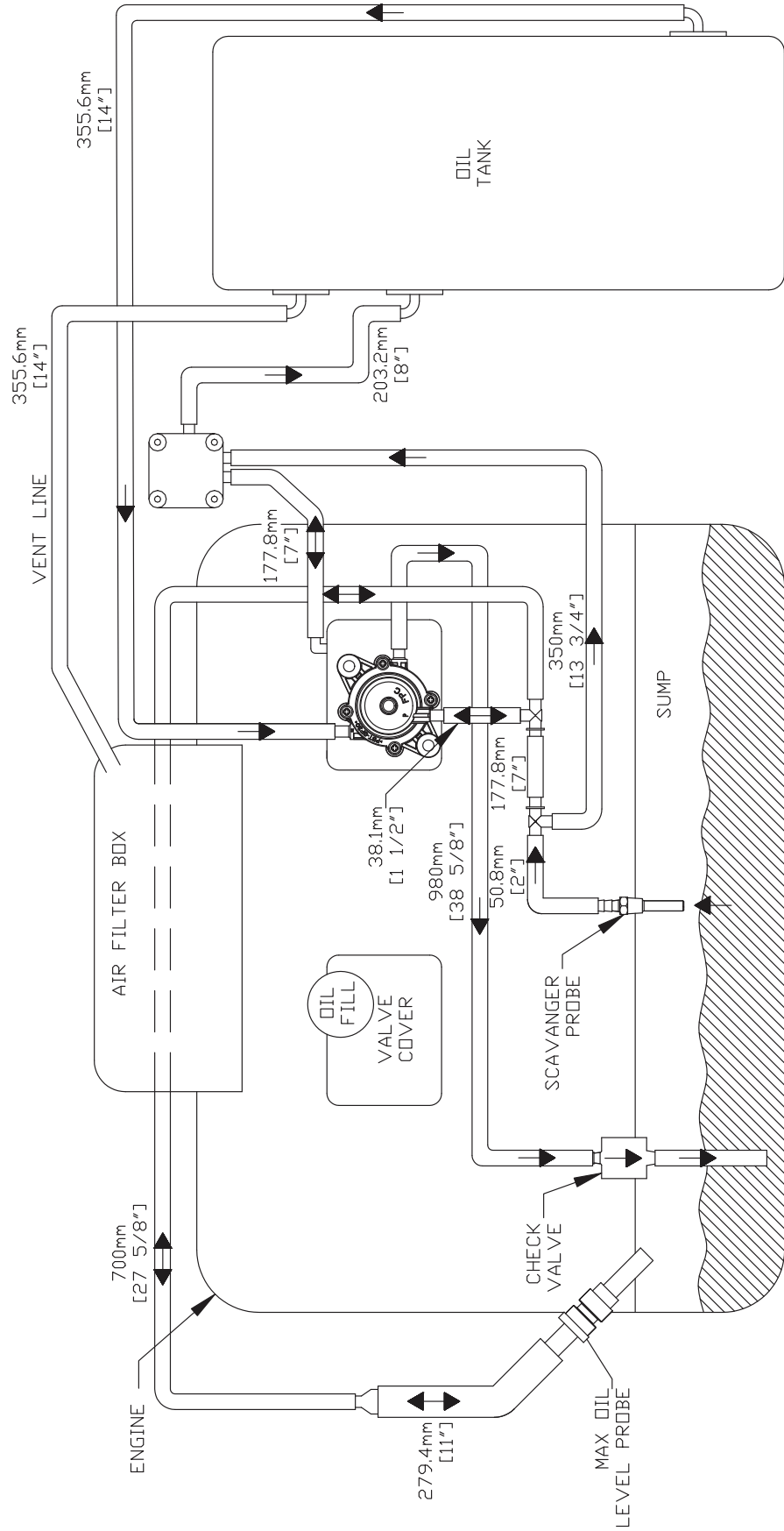

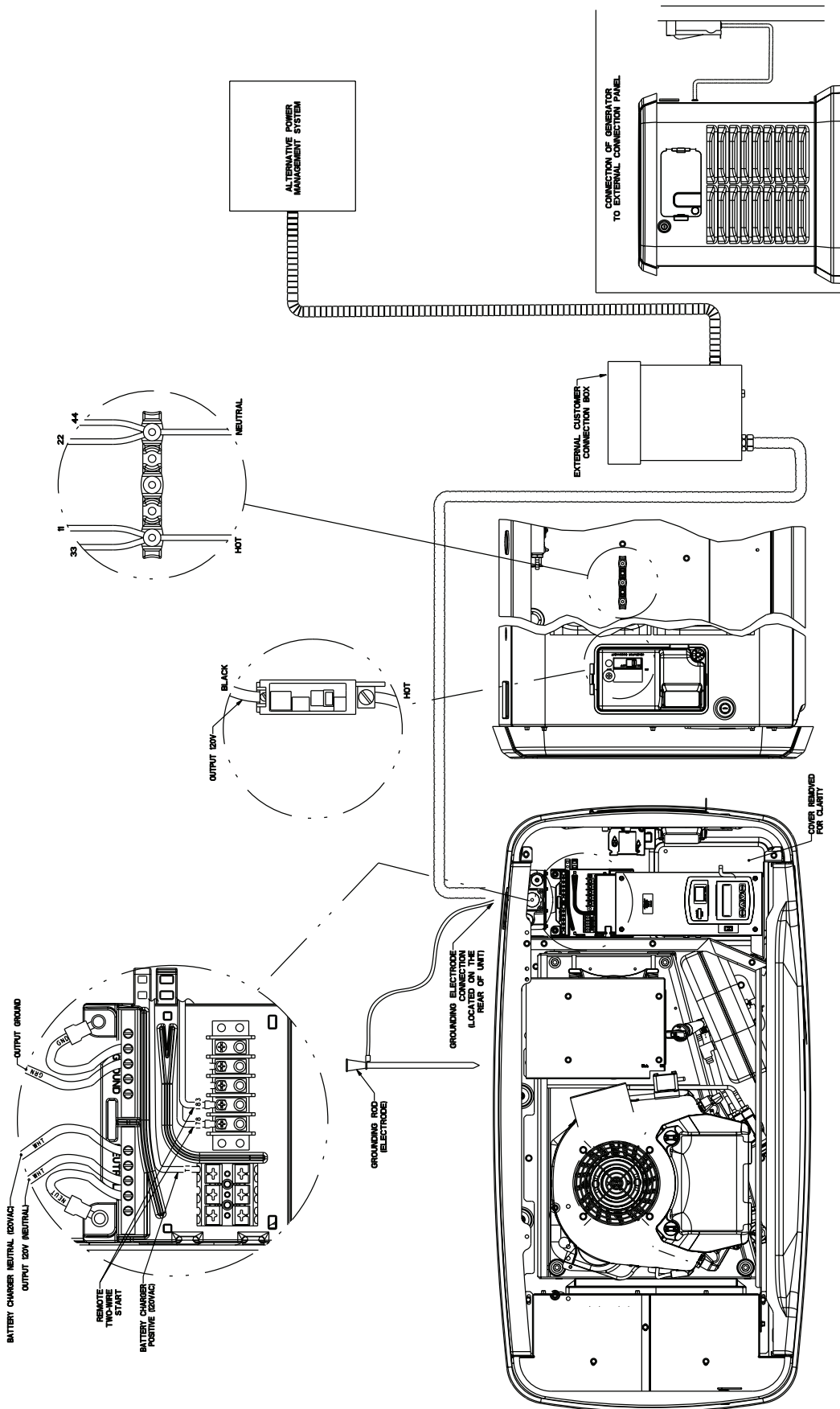

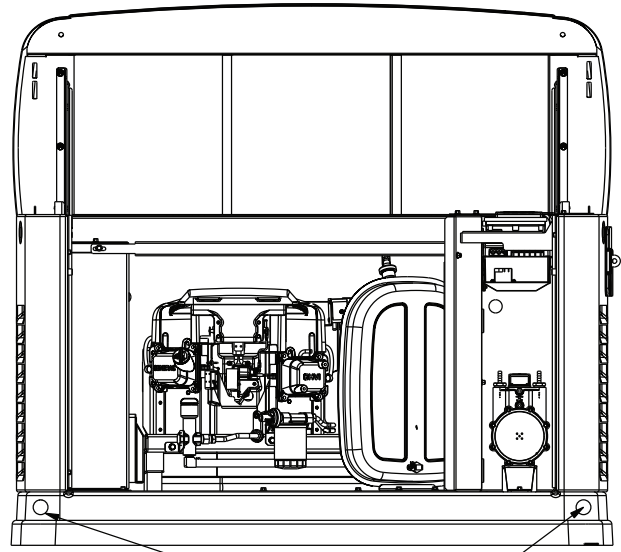

Ø 30.2 [Ø 12]
LIFTING HOLES 4 CORNERS

"DO NOT LIFT BY ROOF"

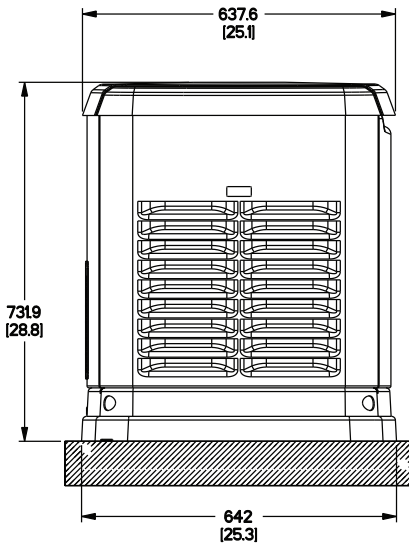

LEFT SIDE VIEW

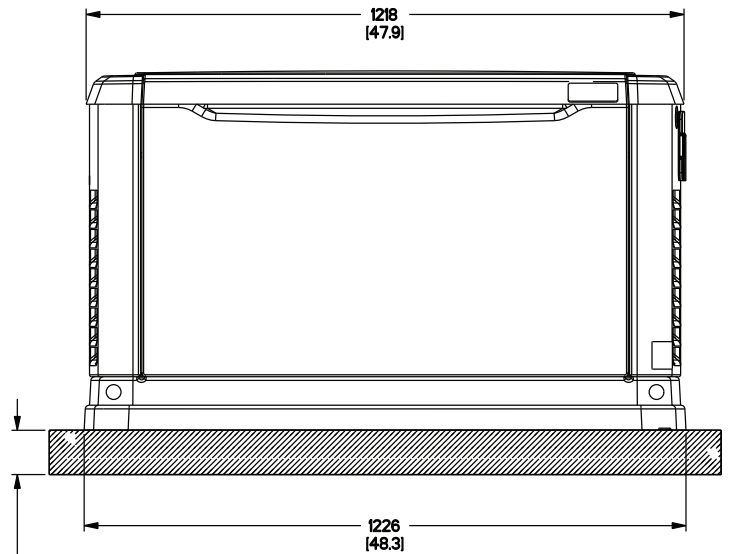

FRONT VIEW

76.2 [3.0]
PEA GRAVEL
MINIMUM

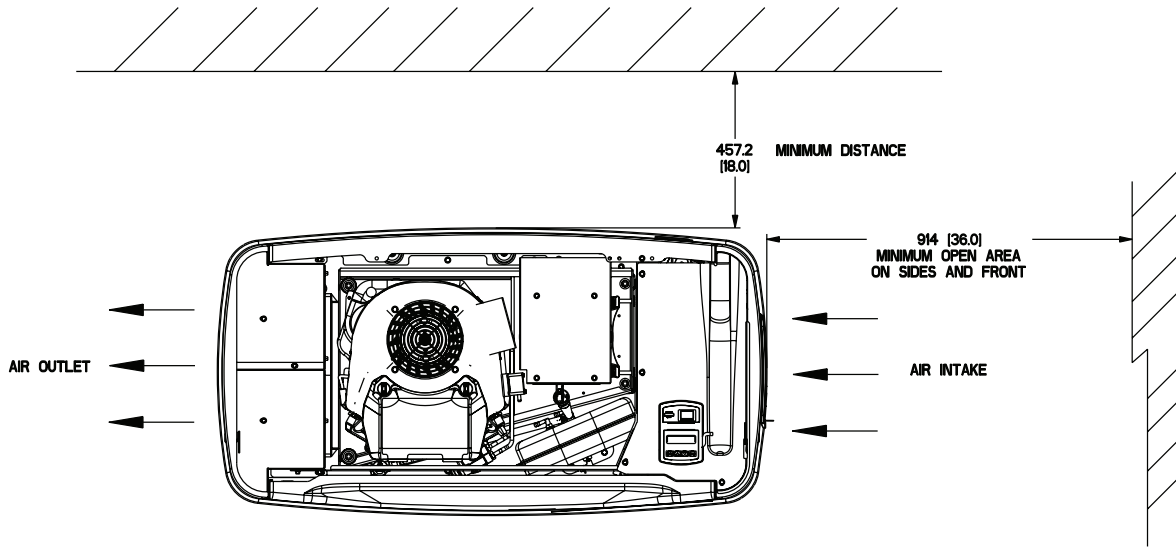

TOP VIEW

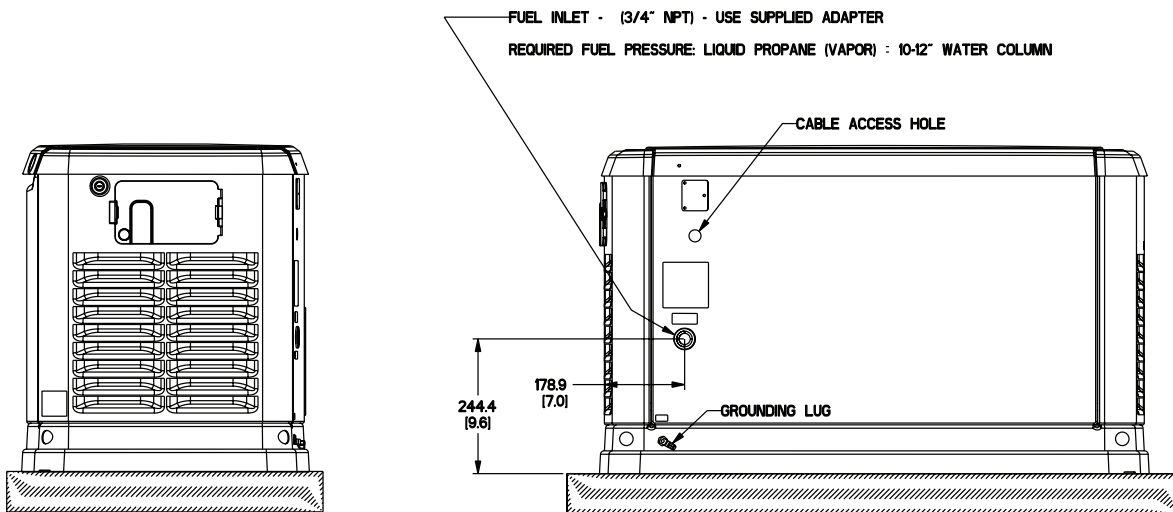
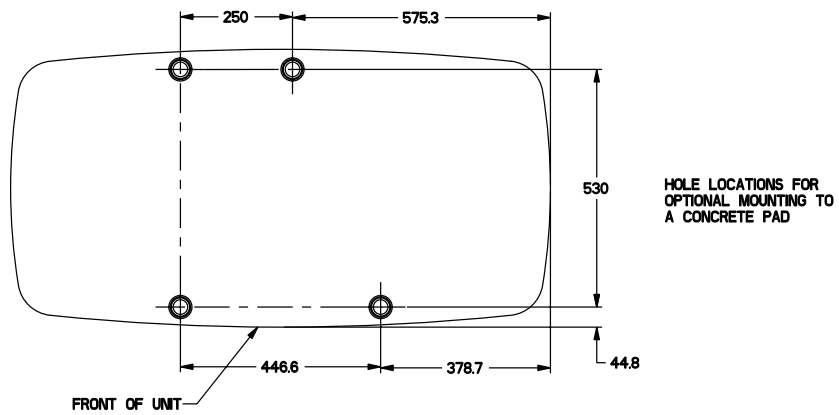

RIGHT SIDE VIEW

REAR VIEW

••ALL DIMENSIONS IN: MILLIMETERS (INCHES)

