

Installation Manual

Montageanleitung
Instructions de montage
Istruzioni per il montaggio

**KNOW
HOW**
INSTALLED

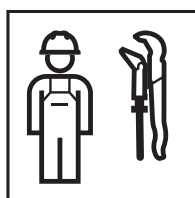

in (mm)

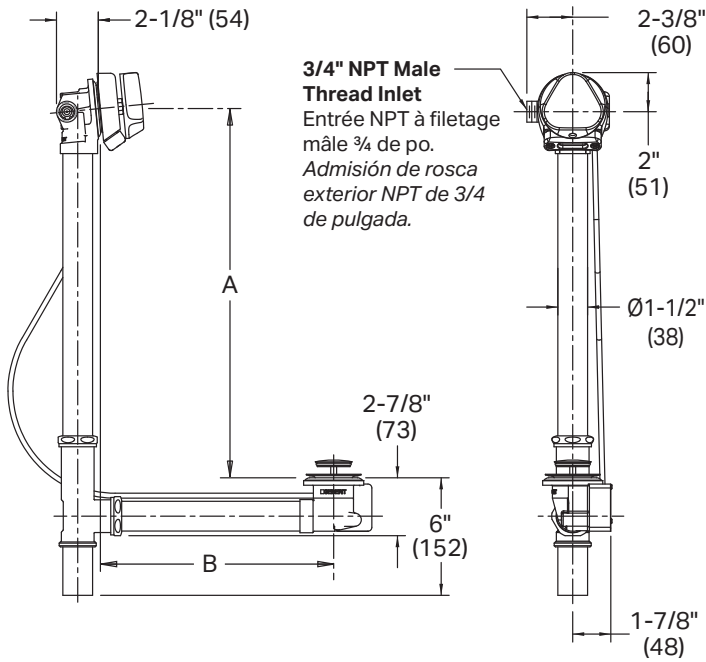

3/4" NPT Male Thread Inlet
 Entrée NPT à filetage mâle 3/4 de po.
 Admisión de rosca exterior NPT de 3/4 de pulgada.

Drain Shoe Length (inches/mm)
 Longueur du coude de vidange (pouces/mm)
 Longitud de la zapata de drenaje (pulgadas/mm)

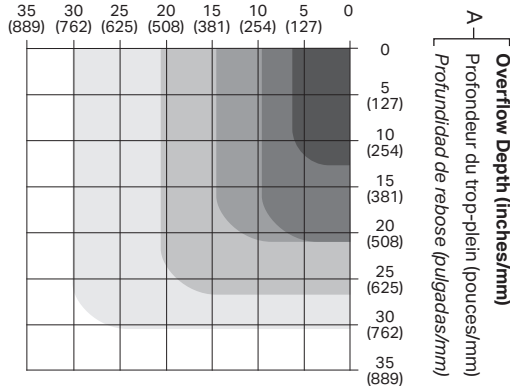

Standard Modular Unit Cable Lengths (inches/mm)

Longueurs du câble de l'unité modulaire standard (pouces/mm)

Longitudes estándar de cable de unidad modular (pulgadas/mm)

Key Légende Clave	Cable Length Longueur du câble Longitud del cable	A	B	Typical Tub Depth Profondeur de bain habituelle Profundidad común de la tina
■	17" (432)	12.75" (320)	6.25" (157)	12"-16" (301-402)
■	27" (678)	21.00" (527)	9.50" (238)	17"-24" (427-602)
■	33" (828)	21.00" (527)	14.50" (364)	17"-24" (427-602)
■	43" (1,079)	26.75" (671)	20.50" (515)	25"-29" (628-728)
■	59" (1,481)	30.50" (766)	30.00" (753)	30" (753)

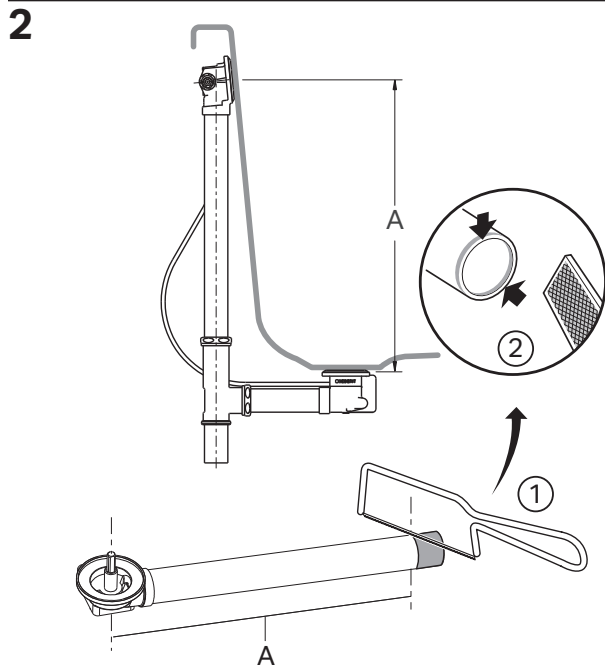
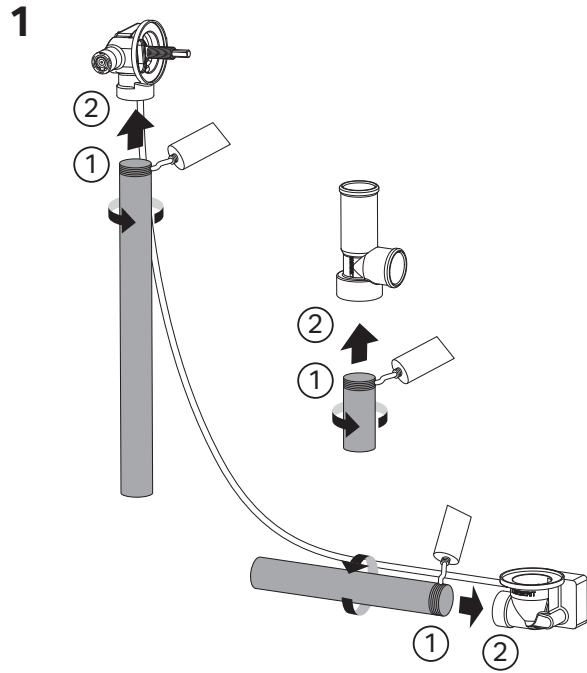

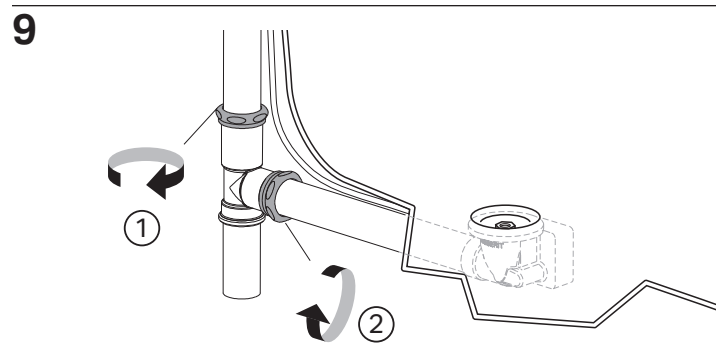
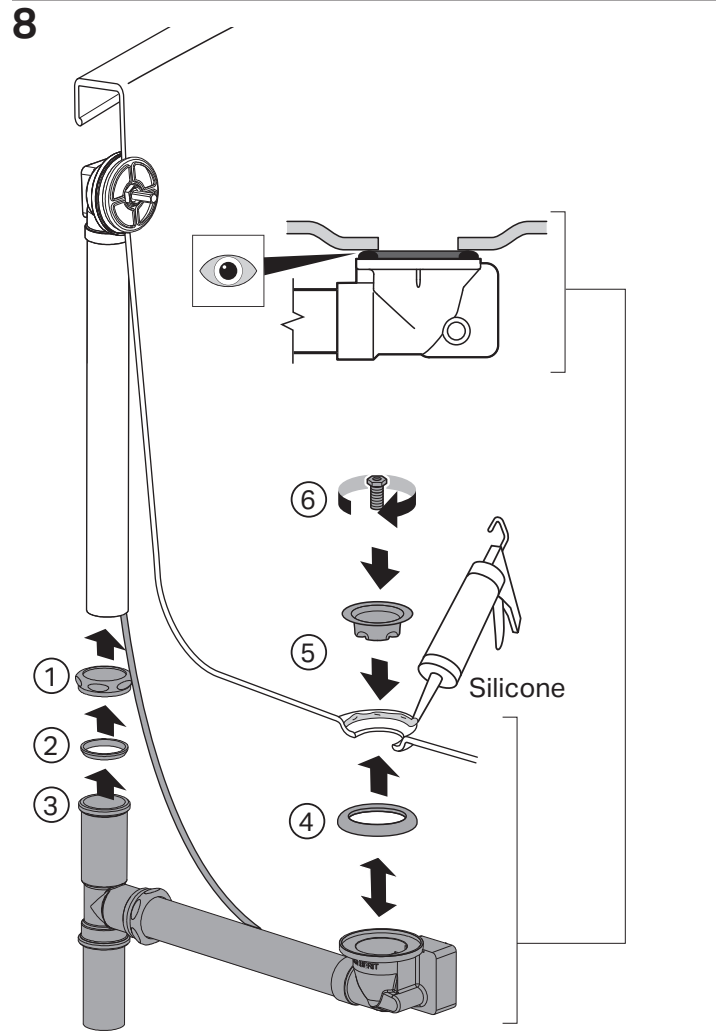
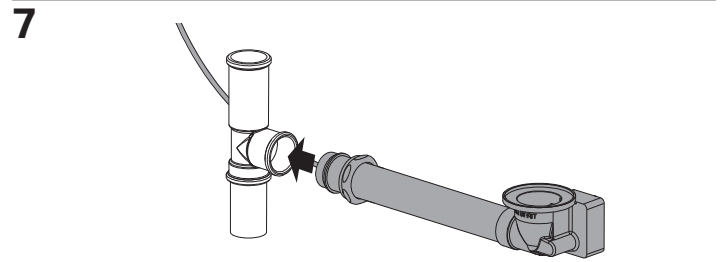
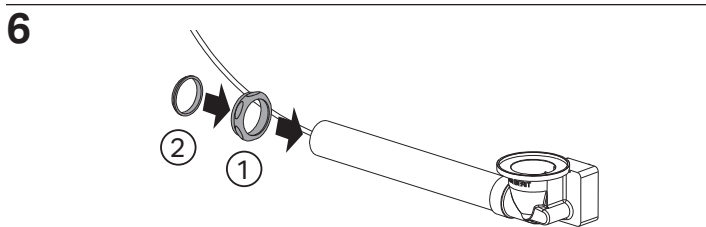
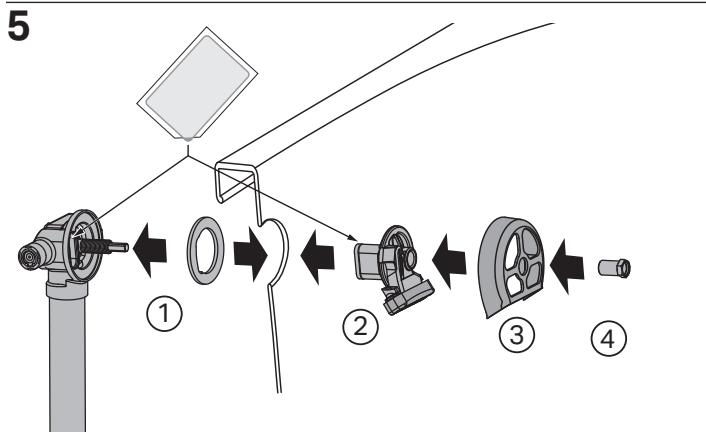
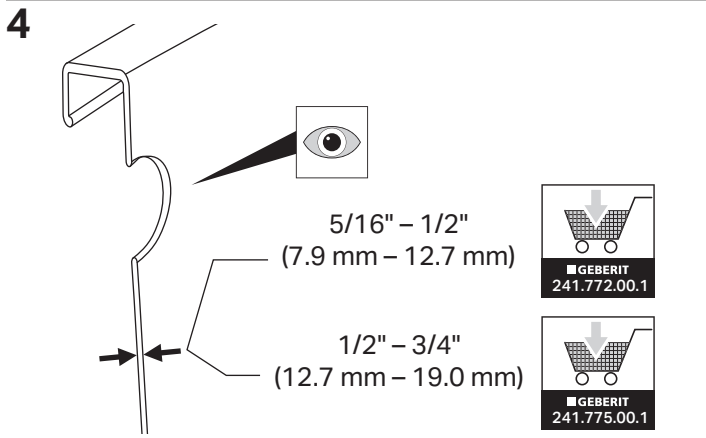
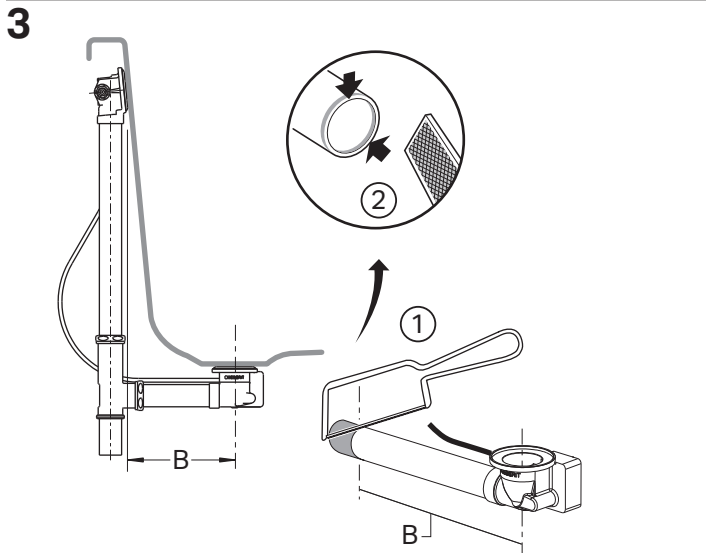

10

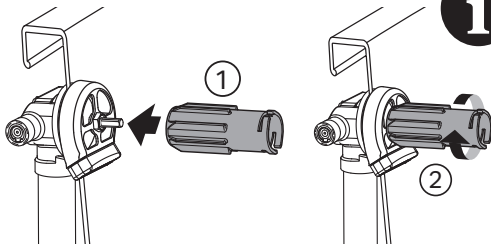

**Hand snug tight
(5 ft-lbs max)**

Serrer à fond à la main (5 pi-lb max)

Apretar bien sólo con la mano (5 pies/lb máximo)

11

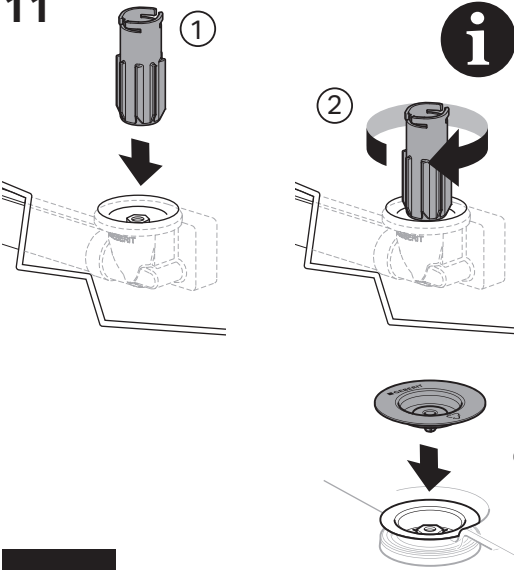

**Hand snug tight
(5 ft-lbs max)**

Serrer à fond à la main (5 pi-lb max)

Apretar bien sólo con la mano (5 pies/lb máximo)

2

12

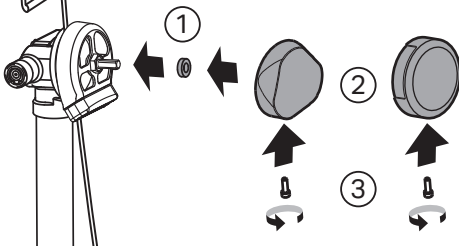
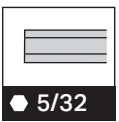

13

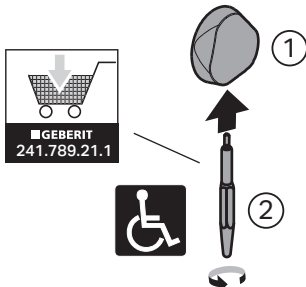

14

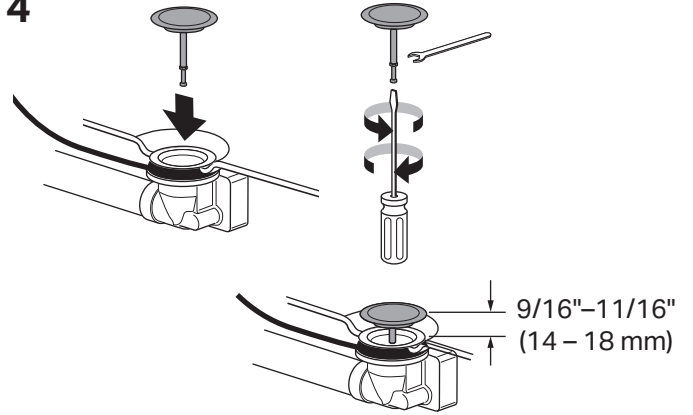

15

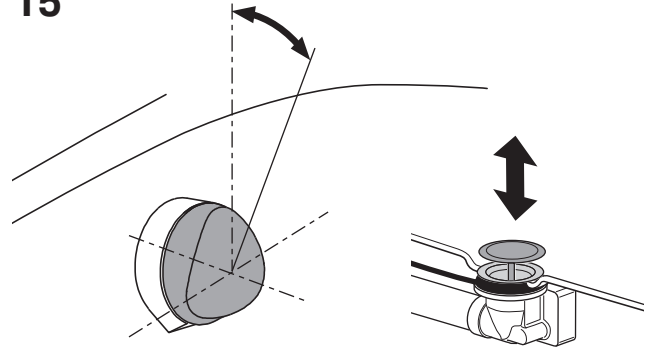

16

Alternative Connection

Autre raccord possible
Conexión alternativa

**Atmospheric vacuum breaker.
Watts model 288A (included).**

Brise-vide atmosphérique
Nombre de watts recommandé,
modèle 288A (inclus)

Interruptor de vacío atmosférico.
Vatios recomendados modelo 288A (incluido).

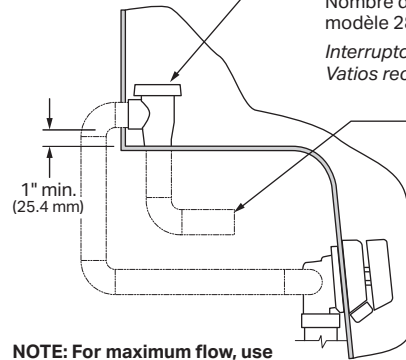

To hot/cold supply stop

Vers le dispositif d'arrêt
d'alimentation en eau
chaude/froide
Para detener suministro
caliente o frío

**Use code approved piping
& fittings**

Utiliser de la tuyauterie et des
raccords conformes au Code
Use tubería y conectores
aprobados por el código

**NOTE: For maximum flow, use
3/4" valves and pipe connections.**

REMARQUE : Pour un débit maximal,
utiliser des obturateurs et des
raccords de tuyaux de 3/4 po

NOTA: Para un flujo máximo, use válvulas
y conexiones de tubería de 3/4".

Geberit

**2100 S. Clearwater Drive
Des Plaines, IL 60018**

USA

P 800-566-2100

F 847-803-5454

→ geberit.us