



Top Mount Refrigerators

FPUI1888L F/R¹

18 Cu. Ft. Top Mount



Product Dimensions

Height (Including Hinges & Rollers)	66-1/8"
Width	30"
Depth	29-7/8"

More Easy-To-Use Features

Humidity-Controlled Crisper Drawers

Keep your fruits and vegetables fresh in our humidity-controlled crisper drawers.

Cool Zone™ Drawer

Clear Dairy Door

Attractive Stainless Steel Exterior

Available in Stainless Steel Left-Swing Door



ENERGY STAR® Maximum Efficiency²

Signature Features



SpaceWise™ Organization System

Our SpaceWise™ Organization system makes it easy to keep food organized and easy to find when you need it.

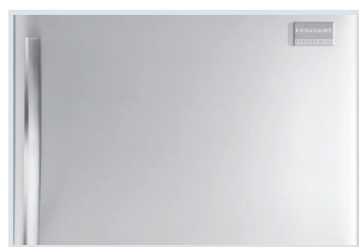

Real Stainless Steel

Real stainless steel with a protective coating that reduces fingerprints and smudges so it's easy to clean.



SpillSafe® Shelves

Designed to keep spills contained, making cleanup a breeze.



Bright Lighting

Our bright lighting makes it easy to see what's inside.

Available in:



Stainless
(F/R³)

¹Left-Swing Door.

²Exceeds minimum ENERGY STAR® standard by at least 30%.

Features	
Door Design	UltraSoft™
Door Handle Design	Stainless Steel
Cabinet Finish (Textured)	Grey
Door Stops	Yes
Door Hinge Covers	Stainless Look
Door Reverse Option	
Left-Swing Door	Yes (R Model Only)
Rollers - Front/Rear	Adjustable/ Yes
Sound Package	Quiet Pack
Toe Grille	Deluxe Metallic
Refrigerator Features	
Interior Lighting	Bright
Refrigerator Shelves	3 Sliding and 1 Fixed SpillSafe™ Adjustable Glass
Cool Zone™ Drawer	Clear
Wine/ Can Rack	White
Store-More™ Crisper Drawers	2 Clear
Humidity Controls	2
Dairy Compartment	Clear Dairy Door
Door Bins	1 Quick-Find, 3 Adj. Half-Width Clear, 1 Fixed Full-Width White
Door Racks	
Non-Slip Bin Liner	2
Tall Bottle Retainers	
Gallon Door Storage	3
Freezer Features	
Door Bins	1 Full-Width Clear
Door Racks	1 Tilt-Out Full-Width Wire
Freezer Shelves	1 Full-Width Glass w/ Sliding Wire Under-Basket
Factory Ice Maker w/ Large Ice Bin	Included (PN# IM115)
Lighting	Yes
Certifications	
ENERGY STAR®	Yes
Specifications	
Total Capacity (Cu. Ft.)	18.28
Refrigerator Capacity (Cu. Ft.)	14.21
Freezer Capacity (Cu. Ft.)	4.07
Power Supply Connection Location	Right Bottom Rear
Water Inlet Connection Location	Bottom Right
Voltage Rating	120V / 60Hz / 15 or 20A
Connected Load (kW Rating) @ 120 Volts ¹	.54
Amps @ 120 Volts	4.5
Minimum Circuit Required (Amps)	15
Shipping Weight (Approx.)	205 Lbs.

¹For use on adequately wired 120V, dedicated circuit having 2-wire service with a separate ground wire. Appliance must be grounded for safe operation.

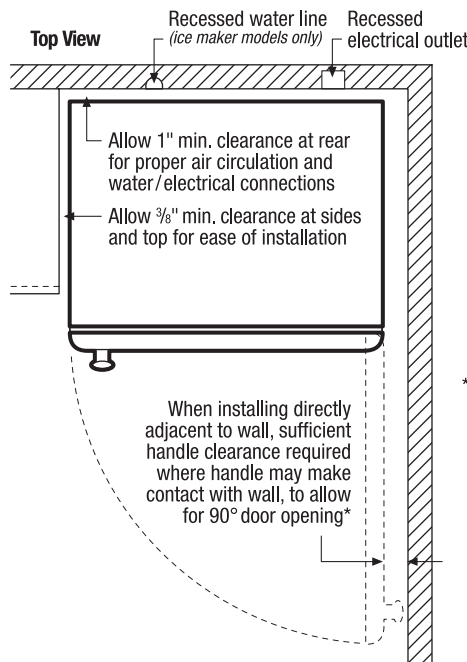
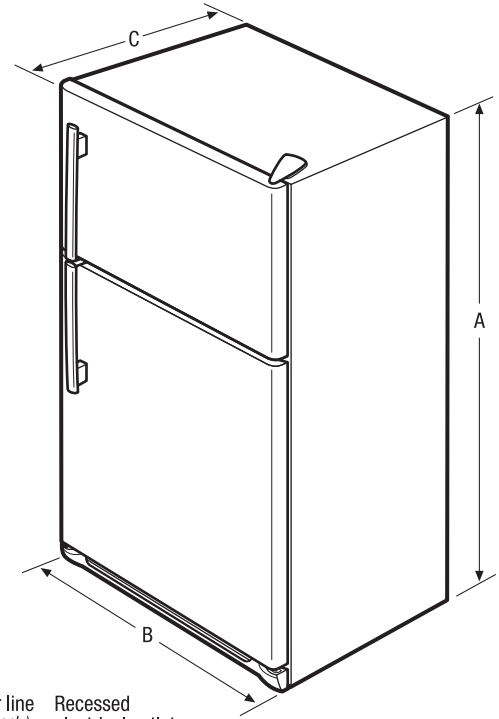

* When installing refrigerator adjacent to wall, cabinet or other appliance that extends beyond front edge of unit, 20" minimum clearance recommended to allow for optimum 140° door swing, providing complete crisper access and removal. (Absolute 3" minimum clearance will ONLY allow for 90° door swing which will provide limited crisper access with restricted removal.)

NOTE: For planning purposes only. Always consult local and national electric and plumbing codes. Refer to Product Installation Guide for detailed installation instructions on the web at frigidaire.com.



Product Dimensions	
A - Height (Incl. Hinges and Rollers)	66-1/8"
B - Width	30"
C - Depth (Incl. Door)	29-7/8"
Depth with Door Open 90°	58-1/8"

Accessories information available on the web at frigidaire.com