



FORECAST

LIGHTOLIER

Specification Sheet

Accessory 3-Light Pan

Models: **F5103-19 Black**
F5103-36 Satin Nickel
F5103-68 Deep Bronze
F5103-81 White

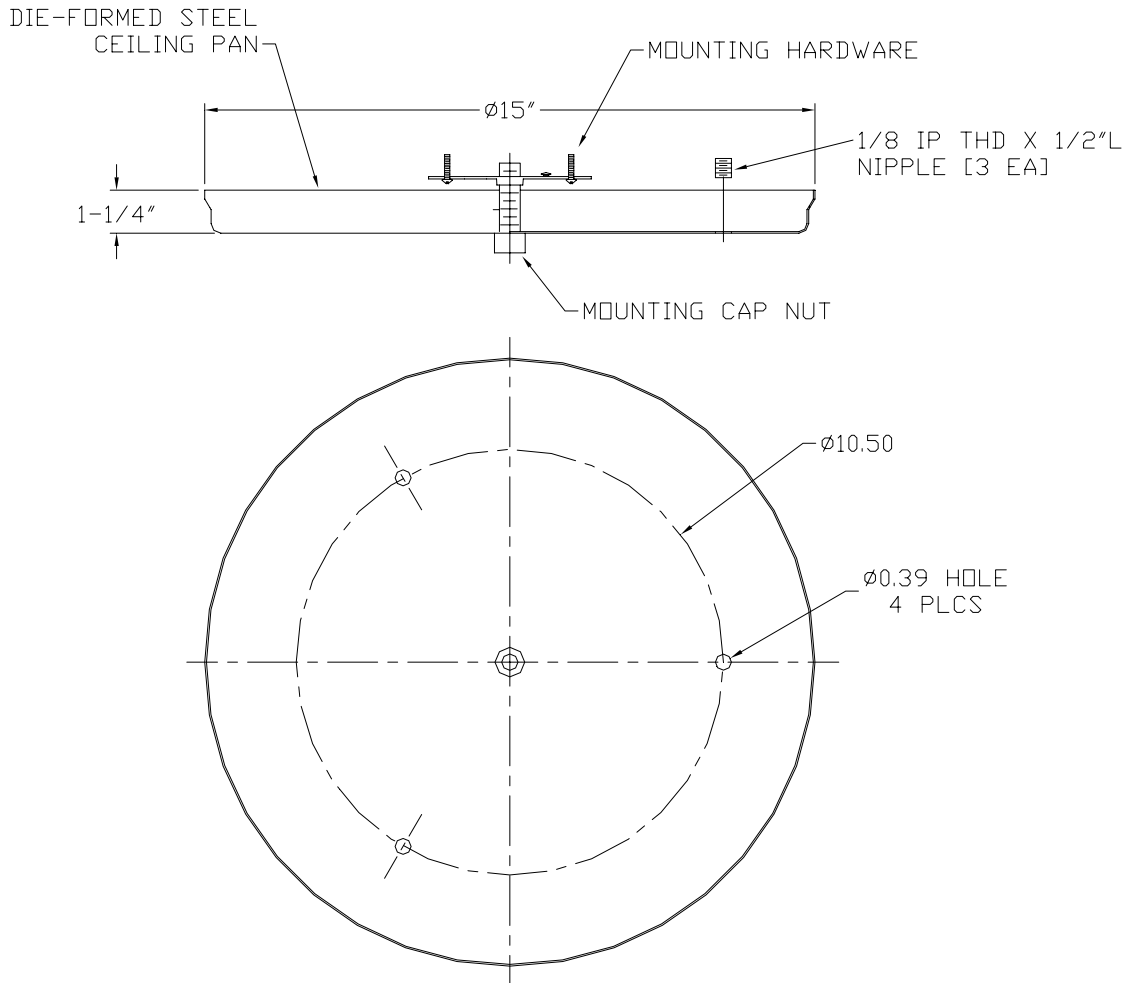

Material: Steel
Finishes: Black -19
Satin Nickel -36
Deep Bronze -68
White -81