



The Warm Side of
TOUGHNESS

Listed to standards
ULC-S610 and UL-127



MONACO FIREPLACE

INSTALLATION AND OPERATION MANUAL

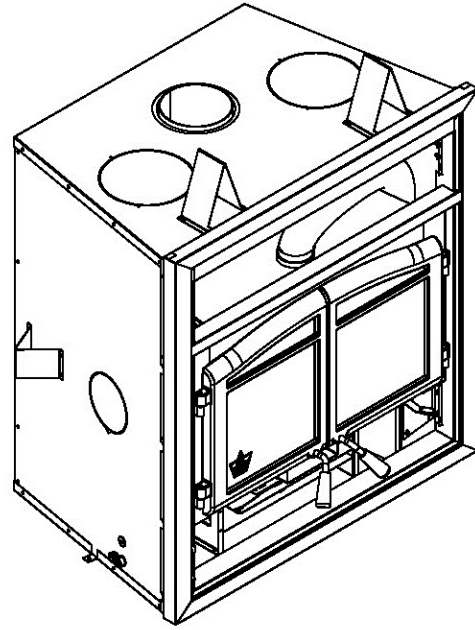
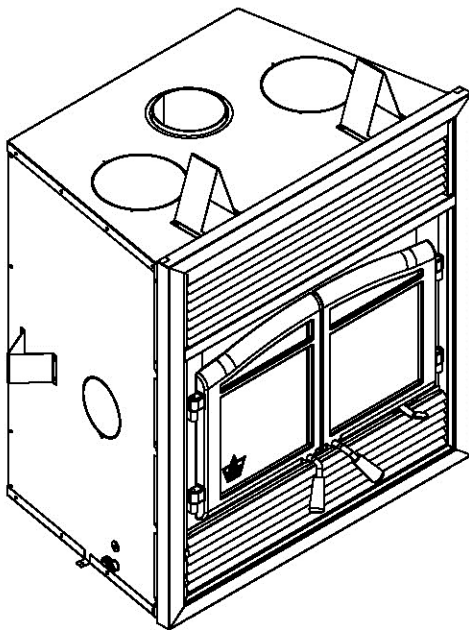

READ AND KEEP THIS MANUAL FOR REFERENCE

STOVE BUILDER INTERNATIONAL INC.

250, de Copenhague, Saint-Augustin-de-Desmaures (Quebec), Canada G3A 2H3

Tel: (418) 878-3040 Fax: (418) 878-3001



This manual is available for free download on the manufacturer's web site. It is a copyrighted document. Re-sale is strictly prohibited. The manufacturer may update this manual from time to time and cannot be responsible for problems, injuries, or damages arising out of the use of information contained in any manual obtained from unauthorized sources.

Installation Instructions

This installation manual will help you obtain a safe, efficient, dependable installation for your fireplace and chimney system. Please read and understand these installation instructions before beginning your installation.

We recommend that our woodburning hearth products be installed and serviced by professionals who are certified in the United States by NFI (National Fireplace Institute®) or in Canada by WETT (Wood Energy Technical Training) or in Quebec by APC (Association des Professionnels du Chauffage).

CAUTION: Do not attempt to modify or alter the construction of the fireplace or its components. Any modification or alteration of construction may void the warranty, listings and approvals of this system. In that case, Stove Builder International (SBI) will not be responsible for damages. Install the fireplace only as described in these instructions

CAUTION: THE INFORMATION GIVEN ON THE CERTIFICATION LABEL AFFIXED TO THE APPLIANCE ALWAYS OVERRIDES THE INFORMATION PUBLISHED, IN ANY OTHER MEDIA (OWNER'S MANUAL, CATALOGUES, FLYERS, MAGAZINES AND/OR WEB SITES).

PLEASE NOTE THAT THE PICTURES SHOWN IN THIS MANUAL ARE GENERIC AND MAY NOT MATCH EXACTLY THE LOOK OF YOUR FIREPLACE.

REGISTER YOUR WARRANTY ONLINE

To receive full warranty coverage, you will need to show evidence of the date you purchased your unit. Keep your sales invoice. We also recommend that you register your warranty online at <http://www.flame-intl.com/warranty-registration.aspx>.

Registering your warranty online will help us track rapidly the information we need on your unit.

TABLE OF CONTENTS

1.	SAFETY RULES FOR OPERATING YOUR FIREPLACE	1
2.	THE FIREPLACE	2
2.1	INTRODUCTION	2
2.1.1	Parts Required	2
2.1.2	Additional Equipment (optional).....	2
2.2	OPERATING THE MONACO FIREPLACE.....	3
2.2.1	Fuel.....	3
2.2.2	The use of manufactured logs	3
2.2.3	First Fires.....	4
2.2.4	Building a Fire.....	4
2.2.5	Maintaining the Fire	4
2.2.6	Primary Air.....	5
2.2.7	Combustion Settings.....	6
2.2.8	Smoking – Causes and Troubleshooting.....	7
2.3	MAINTAINING YOUR MONACO FIREPLACE	8
2.3.1	Creosote – Formation and Need for Removal.....	8
2.3.2	Chimney Maintenance.....	8
2.3.3	Fire Baffle Removal Prior to Cleaning the Chimney	9
2.3.4	Dealing with a Chimney Fire	9
2.3.5	Plated Finish Maintenance	9
2.3.6	Disposal of Ashes.....	10
2.3.7	Refractory Bricks and Slab Replacement.....	10
2.3.8	Glass Care – Replacement.....	10
2.3.9	Glass Care – Cleaning	12
2.3.10	Gasket Replacement	12
2.4	FIREPLACE INSTALLATION.....	13
2.4.1	Locating the MONACO	13
2.4.2	Heart Extension Requirements.....	14
2.4.3	Framing, Facing, Mantel, and Combustible Shelf.....	17
2.4.4	Blower connection.....	25
2.5	HOT AIR DUCTING INSTALLATION.....	26
2.5.1	Gravity Kit.....	26
2.5.2	Central Forced Air Kit (Not tested under EPA certification).....	29
2.6	FRESH AIR KIT (OPTIONAL)	31
2.6.1	Outside Air Installation	31
2.8	DOOR ALIGNMENT	34

3.	THE CHIMNEY	35
3.1	CHIMNEY INSTALLATION NOTES	35
3.2	CHIMNEY INSTALLATION INSTRUCTIONS	36
3.3	OFFSET CHIMNEY INSTALLATION	39
3.4	ANGLED WALL RADIATION SHIELD.....	43
3.5	CHIMNEY SUPPORT INSTALLATION	44
3.6	CHIMNEY CHASE AND MULTIPLE TERMINATIONS.....	45
3.7	INSTALLATION INSTRUCTIONS FOR MASONRY APPLICATION	46
4.	OPTIONS.....	47
5.	APPENDIX.....	48
5.1	SPECIFICATIONS	48
5.2	CLEARANCE TO COMBUSTIBLES	48
5.4	THERMAL CHARACTERISTICS OF COMMON FLOOR PROTECTION MATERIALS*	49
6.	FLAME LIMITED LIFETIME WARRANTY	52

1. SAFETY RULES FOR OPERATING YOUR FIREPLACE

- Use only a Flame glass door, specifically designed for the MONACO FIREPLACE.
- When cleaning the fireplace, the ashes should be placed in a metal container with a tight fitting lid. The closed container of ashes should be placed on a non-combustible floor or on the ground outside the house, pending final disposal. If the ashes are disposed of by burial in soil or otherwise locally dispersed, they should be retained in the closed container until all cinders have thoroughly cooled.

CAUTION: DO NOT INSTALL THIS FIREPLACE IN A MOBILE HOME.

CAUTION: NEVER USE GASOLINE, KEROSENE, CHARCOAL LIGHTER FLUID OR SIMILAR LIQUIDS TO START OR REKINDLE A FIRE IN THIS FIREPLACE. KEEP ALL SUCH LIQUIDS WELL AWAY FROM THE FIREPLACE AT ALL TIMES.

CAUTION: KEEP COMBUSTIBLE MATERIALS AT LEAST 48 INCHES AWAY FROM THE FRONT OF THE FIREPLACE OPENING.

CAUTION: NEVER LEAVE CHILDREN UNATTENDED WHEN THERE IS A FIRE BURNING IN THE FIREPLACE.

CAUTION: NEVER USE GRATE OR ELEVATE FIRE. BUILD WOOD FIRE DIRECTLY ON HEARTH.

CAUTION: DO NOT USE A FIREPLACE INSERT AND OTHER PRODUCTS NOT SPECIFIED FOR USE WITH THIS FIREPLACE.

CAUTION: DO NOT OBSTRUCT AIR INTLETS. THIS FIREPLACE NEEDS AIR FOR ITS GOOD OPERATION.

WARNING: THIS FIREPLACE HAS NOT BEEN TESTED WITH AN UNVENTED OR VENTED GAS LOG SET. TO REDUCE RISK OF FIRE OR INJURY, DO NOT INSTALL AN UNVENTED GAS LOG SET INTO THIS FIREPLACE.

WARNING: DO NOT USE MATERIALS OTHER THAN THOSE LISTED IN THE REPLACEMENT PARTS SECTION DURING INSTALLATION AS THEY MAY BE SAFETY HAZARDS AND A FIRE COULD RESULT.

2. THE FIREPLACE

2.1 INTRODUCTION

The MONACO fireplace is an energy efficient, heat circulating, close combustion fireplace. You will receive a lifetime of comfort and enjoyment from your fireplace provided it is installed, maintained and operated properly.

- Please read these instructions and retain this manual for future reference.
- Before beginning the fireplace installation, consult the local authorities to obtain your building permit and check your local building codes. Install the fireplace only as described in these instructions and using only components from the manufacturers listed in table 2.
- The MONACO is not intended for use with a gas log. Failure to follow these instructions will void the certification and the warranty of the fireplace and may result in an unsafe installation.
- This heating unit must serve as a supplementary heat source. An alternative heat source should be available in the home if needed. The manufacturer cannot be responsible for additional heating costs associated with the use of an alternative heat source. It is highly recommended that the user buys this product from a retailer who can provide installation and maintenance advices.

2.1.1 Parts Required

- The MONACO fireplace
- Insulated chimney made by the manufacturers listed in table 2, with the corresponding specifications :
 - Chimney lengths
 - Elbows (where necessary)
 - Associated components as per these installation instructions.

2.1.2 Additional Equipment (optional)

- Forced air kit
- Gravity venting system
- Outside air kit
- Spark screen

2.2 OPERATING THE MONACO FIREPLACE

2.2.1 Fuel

The MONACO is designed to work best when fuelled with seasoned cordwood. Use solid wood or processed solid fuel firelogs only. Hardwoods are preferred to softwoods since the energy content of wood is relative to its density. Hardwoods will result in a longer burning fire and less frequent refuelling. A moisture content of 15% to 20% (seasoned) is recommended. Wood that has been cut and split and let to dry under a cover for a period of one year will usually meet those criteria. Excessively wet wood will be difficult to burn and will result in lower efficiency, increased creosoting and deposits on the glass and in the chimney. Excessively dry wood will burn well but will also have higher emissions and shorter burning time.

Do not burn scrap or garbage, treated wood or wood such as driftwood from the ocean which has been exposed to salt or other chemicals. Salt or chemicals can corrode the firebox and chimney. Do not burn large amounts of paper, cardboard, Christmas tree branches or building construction materials. Intense firing with these materials may overheat the fireplace, causing damage to the unit, a fire or even possibly igniting a chimney fire if the chimney is creosoted.

CAUTION: DO NOT OVER FIRE THIS HEATER OVER FIRING CAN RESULT IN A SAFETY HAZARD AND CAN PERMANENTLY DAMAGE THE FIREPLACE AND CHIMNEY.

2.2.2 The use of manufactured logs

There are numerous types of manufactured logs sold on the market. You must be very careful with this type of product. Many brands of manufactured logs contain chemical additives. **DO NOT BURN ANY MANUFACTURED LOGS CONTAINING CHEMICAL ADDITIVES. IF YOU DO, YOU MAY OVERHEAT YOUR FIREPLACE, THEREFORE CAUSING A FIRE HAZARD AND VOIDING YOUR WARRANTY.** Logs containing chemical additives burn a lot hotter and were designed for decorative fireplaces. Decorative fireplaces generally have larger, cooler, and less air-tight fireboxes. Your MONACO *FIREPLACE*, on the other hand, has a smaller, completely sealed firebox which attains much higher temperatures. It is therefore not designed to support excessive heat caused by the addition of chemicals in manufactured logs. Manufactured logs made of 100% wood residues do not pose a threat to your fireplace. However, they must be used carefully. Manufactured logs typically release a much larger heat output over a short period of time. Therefore, you cannot place a large quantity of such logs into your fireplace. Start with one log, and gradually increase the load. Never put more than 4 logs. The logs should be of an average size and not exceed 8 inches in diameter.

WARNING: DO NOT POKE OR STIR THE LOGS WHILE THEY ARE BURNING. USE ONLY FIRELOGS THAT HAVE BEEN TESTED FOR USE IN FIREPLACES (SEE ULC/ORD-C127, COMPOSITE FIRELOGS) AND PRIOR TO USE, REFER TO FIRELOG WARNINGS AND CAUTIONS MARKINGS ON PACKAGING.

2.2.3 First Fires

The fresh paint on your fireplace needs to be cured to preserve its quality. Once the fuel load is properly ignited, only burn small fires in your fireplace for the first four hours of operation. Never open the air control more than necessary to achieve a medium burn rate. Make sure that there is enough air circulation while curing the stove. Open one or more windows. The odours can be smelled during the 3 or 4 first fires.

2.2.4 Building a Fire

To start a fire, place several crumpled up balls of newspaper in the firebox behind the andiron. Place small dry pieces of kindling on top of the paper, criss-crossing the kindling so that there are air spaces in between. Keep the fuel far back enough so that air can get underneath. Open the air controls fully and light the newspaper. Once the newspaper and the kindling is well ignited, close the door. Once the kindling fire is well established, cordwood can be added. (See Primary Air Combustion Control section for proper operation of the air controls.). Make sure that cordwood is always behind the andiron.

The unit will burn best with 2-3 pieces of cordwood spaced 1 to 2 inches apart and allowing air to get under the fuel. Criss-crossing or arranging the fuel so that air can get underneath, will help the fire to get started easily. The unit should be operated with the air control fully open long enough to get the cordwood well ignited

CAUTION: PLACE THE WOOD LOGS FAR ENOUGH FROM THE GLASS TO ALLOW PROPER PRIMARY AIR FLOW

2.2.5 Maintaining the Fire

Once the wood has been consumed (or partially consumed) and you have obtained a good bed of embers, you should reload the unit. In order to do so, open the air control to its maximum for approximately 15 seconds prior to opening the fireplace door. Then, proceed by opening the door very slowly. Open it by 2" to 4" (52 to 104 mm) for 10 seconds before opening it completely. This procedure will increase the draft and thus eliminate the smoke which is stagnant in a state of slow combustion in the fireplace. Then, bring the red embers to the front of the stove and reload the unit.

Your MONACO fireplace will work best if a thick bed of hot embers is maintained in the bottom of the firebox, and a minimum of two large pieces of seasoned fuel are added. Combustion efficiency is largely related to establishing a hot ember bed, and hot firebox temperatures. The quicker the fireplace and chimney (flue) get up to normal operating temperatures, the better. A small intense fire is preferred to a large smouldering fire, both to improve combustion efficiency and to reduce the amount of creosote build-up. The best performance will be obtained by adding relatively small amounts of fuel to a well established ember bed, and then operating with the air inlet control open long enough to achieve a hot fire. Use a poker to make an air channel in the embers below the wood. This will allow air to flow under the wood for a more efficient burn. Once you have reached the desired

temperature, the primary air can be set to a medium setting. You know you have reached the desired temperature when, closing the primary air control, you can see a flame at the top of the firebox. The benefit of this technique will be cleaner glass, less creosoting, greater efficiency and the most pleasing fire for your enjoyment.

In order to achieve an optimum efficiency from your unit, we suggest that you operate it with the air control completely closed. Make sure that you have a good fire going and an adequate ember bed before you completely close the air control. Closing the air control too soon will lower combustion efficiency and may cause the fire to die out. The addition of a blower (if not already included) is highly recommended to maximize your unit's efficiency.

2.2.6 Primary Air

There is no flue damper in the MONACO. As in common with air tight stoves, the combustion air control sets the flow of air entering the firebox. This allows for a more precise control of the fire. The combustion air control is located below the door on the right side. The main source of air (primary air) entering the firebox can be diminished by moving the air combustion control from right to left. The primary air is fully opened when the air control is completely moved to the right. The combustion air control should be in the closed position (primary air) when the fireplace is not in use. This will minimize air leakage up the chimney. The combustion air control should be opened before opening the door to minimize the possibility of back draft coming into the room.

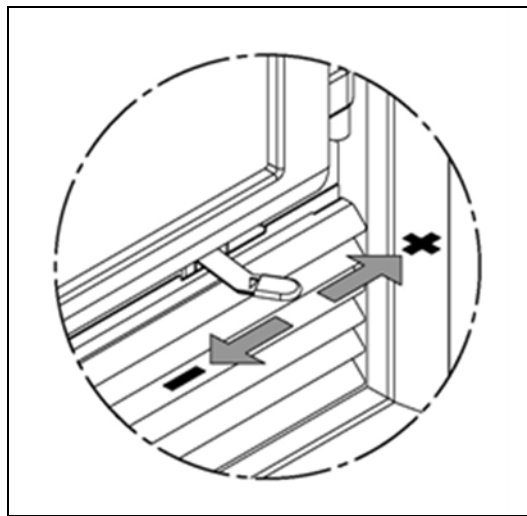

Figure 1

2.2.7 Combustion Settings

Accelerated Combustion

The maximum heat output for the MONACO is achieved by burning with the door closed and the combustion air opened. By this method, the MONACO can produce up to 75,000 BTU of heat per hour. However, it will be necessary to reload with wood every one or two hours. This is the least efficient method of burning the MONACO. Use caution when firing with the combustion air control wide open. Only burn cordwood in this manner. Small dry pieces of softwood and construction scraps will burn very intensely using this method and may damage the firebox.

Medium Combustion

This is the recommended mode of operating the MONACO and should be the one normally used since it will deposit the least amount of creosote on the glass and in the chimney. The combustion air control must be $\frac{3}{4}$ closed. The precise setting will depend on many factors, including chimney length and the moisture content of the wood.

For instance, a long chimney will necessitate closing the combustion air control. To obtain the proper combustion, close the combustion air control completely, and then open it about $\frac{1}{4}$ " to $\frac{1}{2}$ ". Three medium size pieces of wood should be burning on a bed of hot coals. The heat output will be approximately 35,000 BTU per hour and the loading time will be about every 3-4 hours. Softwoods may be burned using this method but the time will be substantially reduced.

Slow Combustion

When the air combustion control is completely closed, the fireplace is in a slow combustion phase. If the heart is hot enough, slow combustion will not stop the fire, but there will be a noticeable change in the flame pattern. The flames will be slow and may appear dirty if the wood is too wet (moisture content of 20% and more). Do not allow the wood to burn without flame, since this will produce excessive creosote in the unit.

Creosote may accumulate on the glass door. This method of burning should be used only after operating the MONACO with the air control opened to produce a hot fire for about an hour or at medium pace for at least 2 hours. Slow combustion can be used at night in order to reduce the heat output and to prolong the burn. The refuelling interval time will be between 6-8 hours.

2.2.8 Smoking – Causes and Troubleshooting

To reduce the likelihood of smoking when opening the door, set the combustion air controls to the right (accelerated) before opening the door. Your fireplace has been designed and tested to provide smoke free operation. Occasionally, there may be a small amount of smoking upon lighting the fire, until the chimney heats up but this should not continue. If the fireplace continues to smoke it is probably for one of the following reasons:

A. Negative pressure in the house

As the fire burns, air goes up the chimney. This air must be replaced through leakage into the house or through the fresh air kit. When operating the MONACO, open a nearby window temporarily to check if there is adequate air supply replacement. If opening a window solves the problem, the house is under negative pressure.

B. Fans operating (e.g.: range hood)

These fans draw air out of the house and may actually cause a negative pressure in the house. Turn off all fans and open a nearby window to determine if this is the cause of the problem.

C. Wet wood

Wet or tarred wood will smoulder and smoke instead of burning properly.

D. Dirty or blocked chimney

Check to make sure the chimney is clear and clean.

E. Chimney not long enough

The minimum system height is 15 feet (4.6m). The chimney must extend at least 3 feet (915 mm) above its point of contact with the roof and at least 2 feet (0.6 m) higher than any roof or wall within 10 feet (3 m) of it. When installed with offsets, the minimum system height is 15 feet (4.6 m) to 17 feet (5.2 m) as per Table 1. Additional height will increase draught and will decrease the tendency to smoke. If only the minimum chimney height is installed, operating conditions must be optimal (interior chimney, minimum height of 18” before any offset, etc.).

F. Poor chimney draft

With no fire, there should be sufficient draught to exhaust cigarette smoke introduced under the baffle. Chimneys installed against an outside wall without protection may generate back draught problems which will cause start-up problems. To prevent this, open a nearby window, roll up a piece of paper and light it. Then, hold it in the upper part of the firebox to warm up the chimney. Wait until the draught is sufficient, then start the fire.

IMPORTANT NOTES

- A. Do not block the hot air vents to the fireplace as this will cause the fireplace to overheat.
- B. Never start a fire using gasoline, kerosene, charcoal lighter fluid or any other combustible liquid.
- C. Do not burn coal. The sulphur in coal will corrode the firebox.
- D. Do not burn driftwood which has been in the ocean or salt water. The salt will corrode the firebox and chimney.
- E. Do not abuse the unit by burning paper or cardboard or construction material such as pressed wood, plywood or lumber.
- F. Do not allow the wood to smoulder or burn without flame, since this will produce excessive creosote in the unit.

2.3 MAINTAINING YOUR MONACO FIREPLACE

2.3.1 Creosote – Formation and Need for Removal

When wood is burned slowly without a flame, it produces tar and other organic vapours which combine with expelled moisture to form creosote. The creosote vapours condense in; the relatively cool chimney flue of a slow-burning fire. As a result, creosote residue accumulates on the flue lining. When ignited this creosote makes an extremely hot fire.

The chimney shall be inspected at least twice a year during the heating season to determine when a creosote build-up has occurred. When creosote has accumulated it shall be removed to reduce the risk of a chimney fire.

2.3.2 Chimney Maintenance

Regular chimney inspection and maintenance combined with proper operation will prevent chimney fires. Keep your chimney clean. Do not allow more than 1/16" creosote build up in your chimney. The amount of creosote will depend on variables such as frequency of use and type of fire. We recommend that you:

- A. Initially inspect the chimney system weekly. From this, you will learn how often it will be necessary to clean your chimney.
- B. Have your chimney cleaned by a qualified chimney sweep. If you wish to clean it yourself, we recommend using a stiff plastic or non-metallic brush. If a metal brush is used, its size should be slightly smaller than the flue to avoid damaging the chimney. Do not use a brush that will scratch the stainless steel interior of the chimney.
- C. Do not expect chemical cleaners to keep your chimney clean. The rain cap can be removed for inspection and/or cleaning of the chimney.

2.3.3 Fire Baffle Removal Prior to Cleaning the Chimney

Before starting to clean your chimney, we recommend that you remove the fire baffle to avoid creosote dust collection on top of the baffle. Follow the steps below to remove the fire baffle:

1. Remove the front air tube by pulling out the cutter pin on the side of the tube. They are located at the top, underneath the baffle.
2. Lift the baffle and slide it out of the fireplace. You now have access to the chimney.

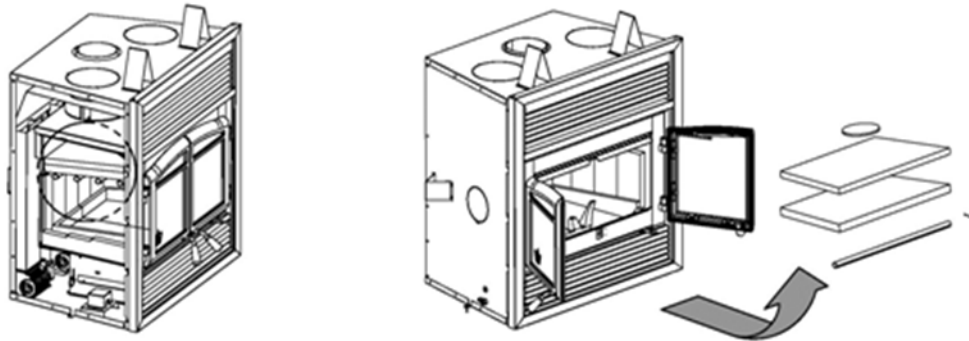

Figure 2

2.3.4 Dealing with a Chimney Fire

Regular chimney maintenance and inspection can prevent chimney fires. If you have a chimney fire, follow these steps:

1. Close the fireplace door and the combustion air controls;
2. Alert your family of the possible danger;
3. If you require assistance, alert your fire department;
4. If possible, use a dry chemical fire extinguisher, baking soda or sand to control the fire. Do not use water as it may cause a dangerous steam explosion;
5. Check outside to ensure that sparks and hot embers coming out of the chimney are not igniting the roof;
6. Do not use the fireplace again until your chimney and fireplace have been inspected by a qualified chimney sweep or a Fire Department Inspector;

2.3.5 Plated Finish Maintenance

Use a metal polish and a soft cloth to clean the plated finishes on the optional louvers. Do not use abrasives such as steel wool, steel pads or an abrasive cleaner for they may scratch the finish.

2.3.6 Disposal of Ashes

Do not attempt to clean the fireplace when the unit is hot. Ashes should be placed in a metal container with a tight fitting lid. The closed container of ashes should be placed on a non-combustible floor or on the ground, well away from combustible materials pending final disposal. If the ashes are disposed of by burial in soil or otherwise locally dispersed they should be retained in the closed container until all cinders have thoroughly cooled. Do not attempt to clean the stove when the unit is hot.

2.3.7 Refractory Bricks and Slab Replacement

The intense heat of the fire will normally cause hairline cracks in the refractory material. These cracks can be minimized by proper curing as described in **Section 2.2.3** “First Fires”. They will not normally diminish the effectiveness of the refractory. If large cracks develop, then the refractory should be replaced. To replace the refractory bricks, follow these steps:

1. Remove the log holder (1) held in place by the two torx screws.
2. Remove the front floor brick (2)
3. Remove the left side bricks (3)
4. Remove the right side bricks (4)
5. Remove the rear bricks (5)
6. Remove the floor refractory slab (6)

To install the new bricks, follow the above steps in reverse.

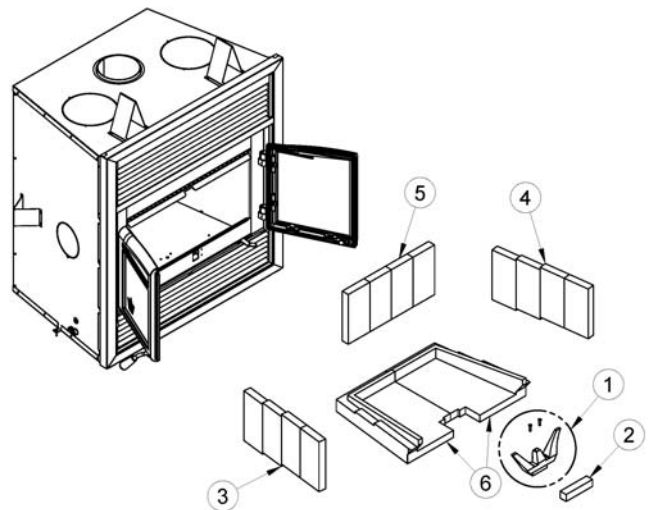

Figure 3

2.3.8 Glass Care – Replacement

The two glasses used in the MONACO fireplace are 5 mm thick and have the same dimension of 14 1/2” D x 13 3/16” H x 12” W. They are tested to reach temperatures up to 1400° F. If a glass breaks, it must be replaced with one having the same specification. Contact your FLAME dealer to obtain a genuine replacement part (refer to “replacement parts” section, in appendix to get the proper part number).

WARNING: TEMPERED GLASS OR ORDINARY GLASS WILL NOT WITHSTAND THE HIGH TEMPERATURES OF THE MONACO FIREPLACE.

WARNING: DO NOT ABUSE THE GLASS DOOR BY SLAMMING IT AGAINST THE FIREPLACE.

WARNING: DO NOT OPERATE THE FIREPLACE WITH A CRACKED OR BROKEN GLASS.

In order to replace the glass, use the following procedure;

- 1- Remove the six glass retainers (4) held in place by six screws (1).
- 2- Remove the glass frame (2 and 3)
- 3- Remove the glass (5)
- 4- To install the new glass, follow the above steps in reverse order.

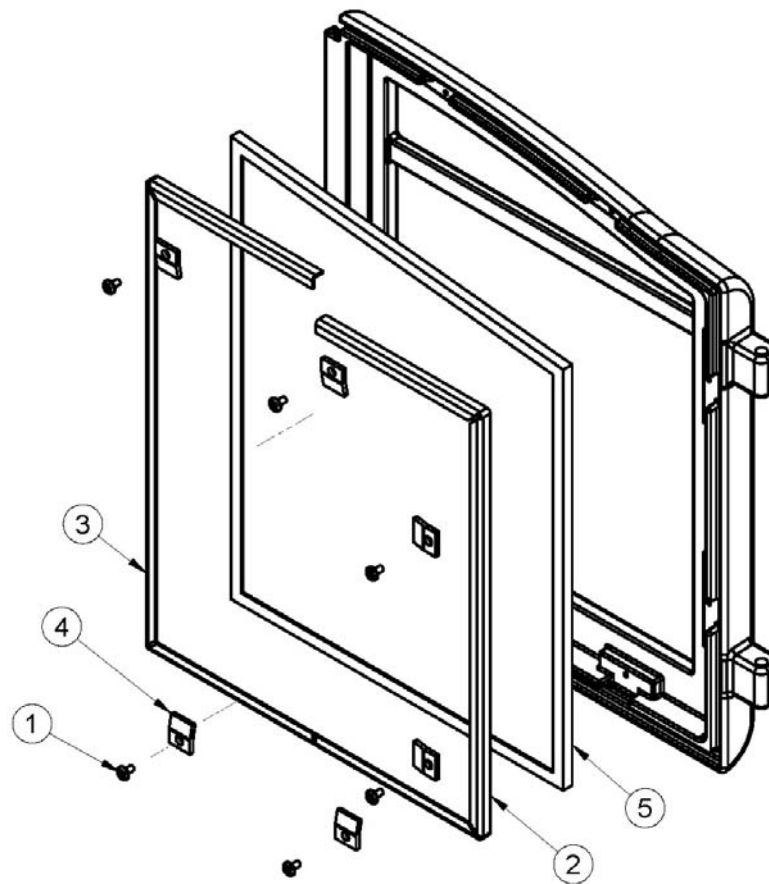

Figure 4

2.3.9 Glass Care – Cleaning

The MONACO is designed to keep the glass clean under normal operating conditions. If the MONACO is operated continuously with the combustion air controls closed, the glass will tend to get dirty unless the fuel, firebox and glass are maintained at higher temperatures. To clean the glass, there are a number of specially designed cleaners. Your authorized FLAME dealer can recommend a suitable cleaner which is available in your area. Regular household glass cleaners will not clean creosote and they usually contain ammonia that may stain the glass permanently.

WARNING: ONLY WASH THE GLASS WHEN IT'S COLD.

WARNING: DO NOT USE ABRASIVES SUCH AS STEEL PADS, STEEL WOOL OR OVEN CLEANER AS THEY WILL SCRATCH THE GLASS.

2.3.10 Gasket Replacement

Remove the doors from the unit and lay them on a clean, non-abrasive surface. To replace the gasket around the door frame, first remove the old gasket and adhesive. Make sure that the surface is totally clean before applying new adhesive (a high temperature silicone caulking rated for at least 500°F, 260°C, is suitable) or adhesion problems may result. Apply the adhesive inside the door groove (gasket channel) and install the new gasket with a gentle pressure. Let dry for at least 24 hours. To replace the glass gasket, simply remove the glass retainers holding the glass to the door frame. Remove the glass and peel off the gasket surrounding it. Replace it by a new, self-adhesive glass gasket. The proper replacement gaskets are available from your FLAME dealer in the following dimensions:

<u>Gasket</u>	<u>Length</u>	<u>Dimensions</u>
Glass gasket	51 3/4" (132 cm)	“U” Shape self adhesive
Door frame gasket	51 3/4" (132 cm)	Flat 1/4" x 1/2"
Middle door frame gasket	15 1/2" (39 cm)	Flat 1/4" x 1/2"

2.4 FIREPLACE INSTALLATION

2.4.1 Locating the MONACO

Please note that the firebox refractory bricks and slabs come in a box inside your fireplace's firebox. Once you have installed your fireplace, refer to **Section 3.2.7** to set the brick in place.

- A. The best location to install your fireplace is determined by considering the location of windows, doors, and the traffic flow in the room where the fireplace is located, allowing space in front of the unit for the heart extension and the mantel, and taking into consideration the location of the hot air ducts (optional), outside air kit and chimney. If possible, you should choose a location where the chimney will pass through the house without cutting floor or roof rafters.
- B. Usually, no additional floor support is needed for the fireplace. The adequacy of the floor can be checked by first estimating the weight of the fireplace system. Weights are given in the appendix. Next, measure the area occupied by the fireplace which is normally $36\frac{3}{4}" \times 26"$. Note the floor construction and consult your local building code to determine if additional support is needed.
- C. The MONACO may be installed directly on the floor or on a raised base (for proper guidelines, refer to "Heart Extension Requirements") and a minimum of 7 feet (2.15 m) measured from the base of the appliance to the ceiling is required. The hearth extension is to be installed only as illustrated in the drawing below.

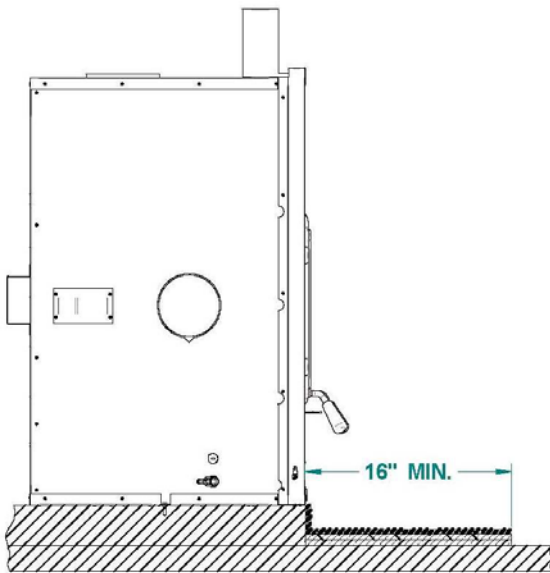

Figure 5. Installation on raised base

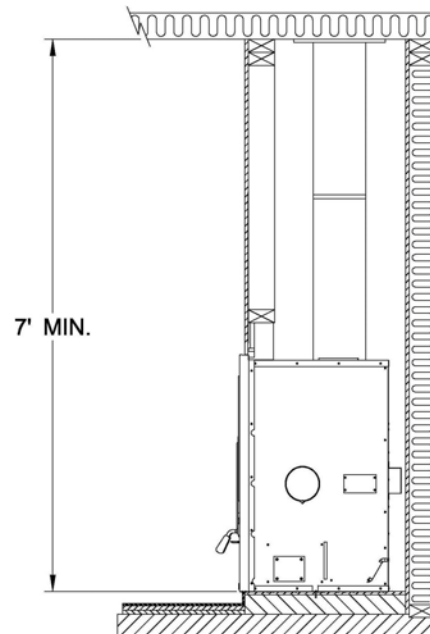

Figure 6. Ceiling clearance requirements

2.4.2 Heart Extension Requirements

The hearth extension floor area (see (A) on Figure 10) must extend at least 16" (40 cm) in front and at least 8" (20 cm) on each side of the door opening (see Figure 7). The joint between the hearth extension and the fireplace hearth needs to be made of non-combustible material such as sheet metal or sand-cement grout (not included) as shown on Figure 8.

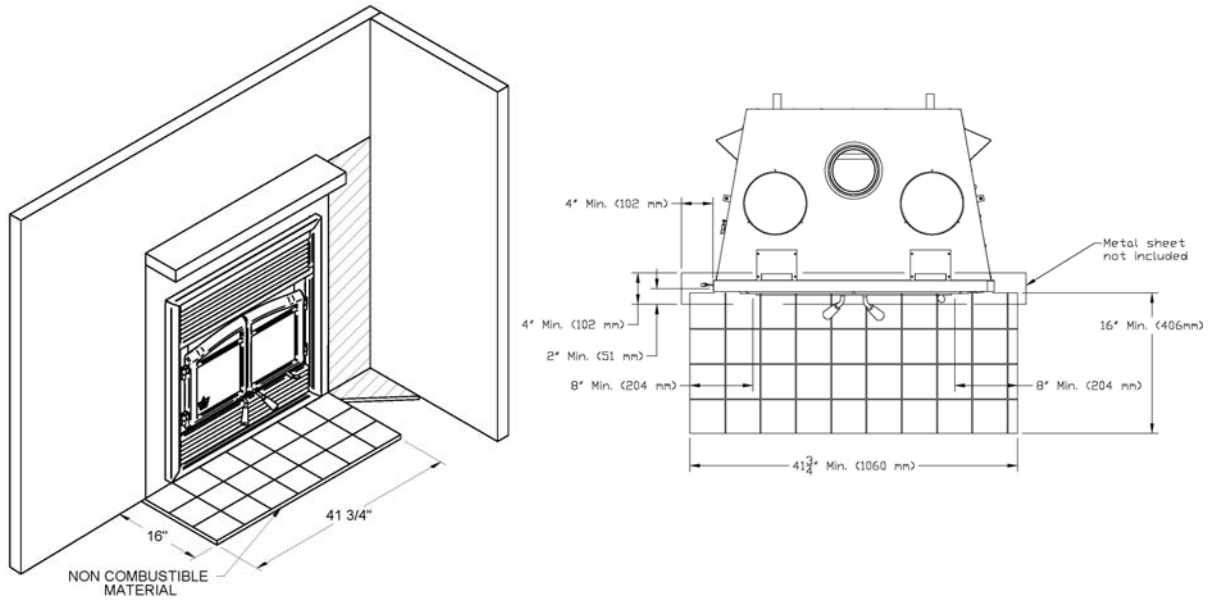

Figure 7

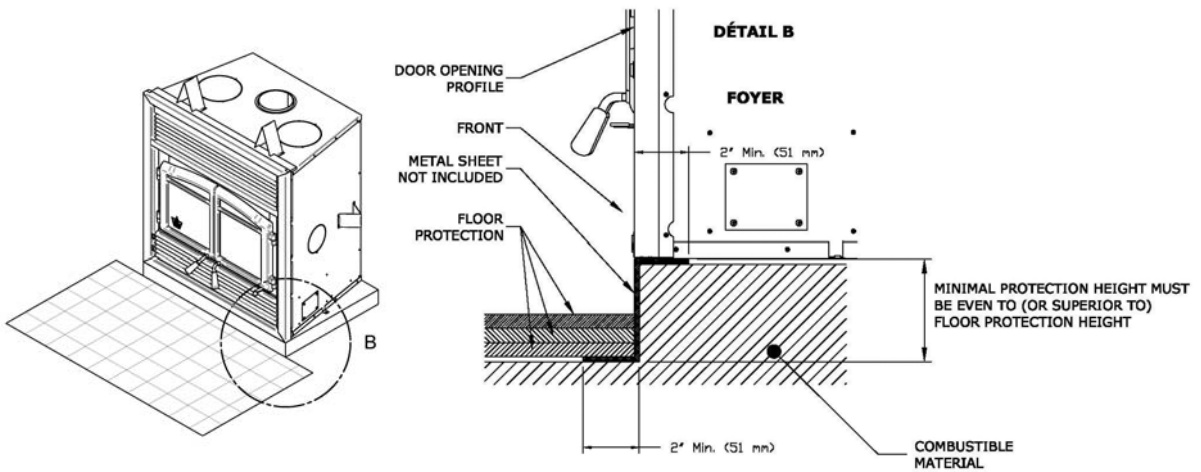

Figure 8

When the fireplace is installed directly on the floor, a noncombustible floor protection in front of the unit must be installed and have an R value insulation equal to or greater than 1.00. The use of an R value is convenient when more than one material is going to be used in the hearth extension to cover the combustible surface. This is because R values are additive, whereas K values are not. To find the corresponding R factor to use for some selected materials, please see Appendix section. Please note that the minimum height of the raised base of the fireplace should match or exceed the height of the floor protection.

2.4.2.1 R Calculations

There are two ways to calculate the R factor of the floor protection. First, by adding the R-values of the proposed materials or if some K and thickness values are given, by converting them to R values.

To calculate the R factor for a composite floor protection made of a combination of alternative materials, simply add the R-values of those materials. If the result is equal to or larger than the required R value, the combination is acceptable. For R-values of some selected materials, see Appendix section.

Example:

Required floor protection R of 1.00. Proposed materials: four inches of brick and one inch of Durock[®] board

$$\text{Four inches of brick (R = 4 x 0.2 = 0,8) plus 1 inch of Durock}^{\text{®}} \text{ (R = 1 x 0.52 = 0.52).}$$
$$0.8 + 0.52 = \mathbf{1.32.}$$

This R value is larger than the required 1.00 and is therefore **acceptable**

In the case of a known K and thickness of alternative materials to be used in combination, convert all K values to R by dividing the thickness of each material by its K value. Add the R values of your proposed materials as shown in the previous example.

Example:

$$\text{K value} = 0.75$$

$$\text{Thickness} = 1$$

$$\text{R value} = \text{Thickness/K} = 1/0.75 = 1.33$$

2.4.2.2 How to eliminate the need of a R value

It is however possible to eliminate the R value by elevating the unit from 4" above the floor (see Figure 9), but the joint between the extension of the hearth and the fireplace must be protected by a non-combustible material. For example, a sheet metal (not included) as illustrated in Figure 9 (B). Please note that a combustible floor protection of at least 16" long must be installed in front of the fireplace as illustrated in Figure 9 (A).

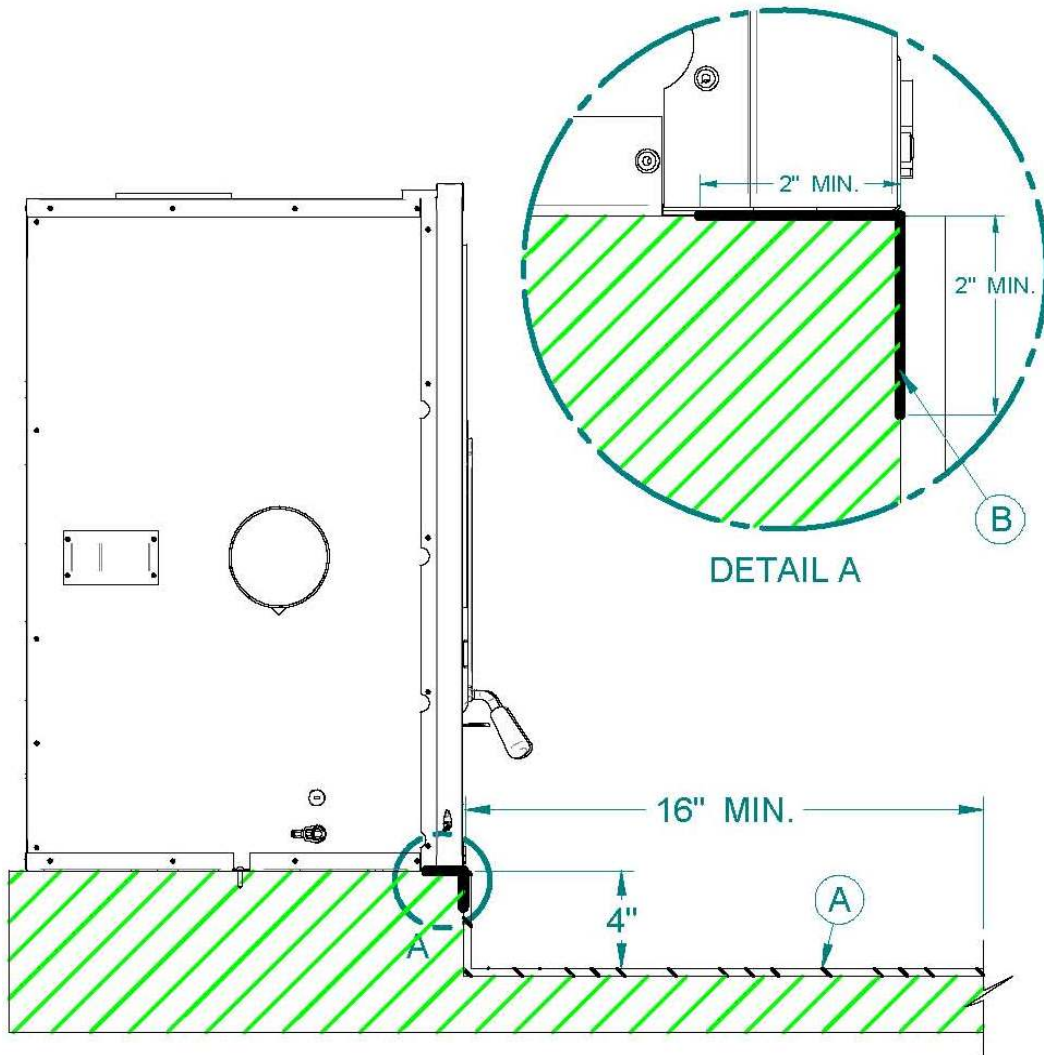

Figure 9

2.4.3 Framing, Facing, Mantel, and Combustible Shelf

- **Framing**

The construction of the framing, facing, and mantel must be in accordance with the standards and the following illustrations (figures 10 to 14):

A. Frame the fireplace using 2" × 3" (5 cm x 8 cm) or heavier lumber.

WARNING: COMBUSTIBLE FRAMING MATERIAL CANNOT BE USED IN THE SPACE DIRECTLY ABOVE THE FIREPLACE, EXCEPT FOR THE STUDS ABOVE THE FACING THAT SUPPORT THE FACING MATERIAL AND MANTEL. THIS AREA MUST REMAIN EMPTY FOR A HEIGHT OF 7' (2,15 M) MEASURED FROM THE BASE OF THE APPLIANCE.

B. Frame the fireplace with vertical studs at the sides of the fireplace running from floor to ceiling (see figure 14). Position the studs back from the front edge of the fireplace, a space the thickness of the facing material so that the facing can be installed flush with the fireplace facing (within limitations of figure 14). Frame headers between the vertical studs only as follows:

- Place 2" × 3" or 2" × 4" headers, only along the upper part of the front, side and back faces. Do not put wood or any combustible material within the area above the fireplace except on the front facing.
- Place headers only as required to support the facing and mantel.

WARNING: DO NOT PACK REQUIRED AIR SPACES WITH INSULATION OR OTHER MATERIALS.

WARNING: THE FIREPLACE MUST NOT BE IN CONTACT WITH ANY INSULATION OR LOOSE FILLING MATERIAL. COVER THE INSULATION WITH GYPROC PANELS AROUND THE FIREPLACE.

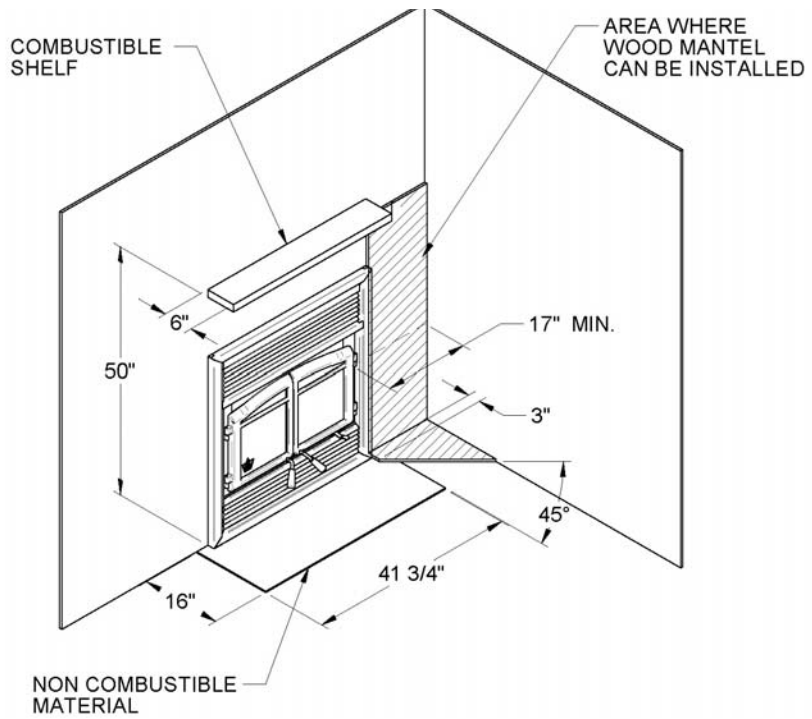

Figure 10

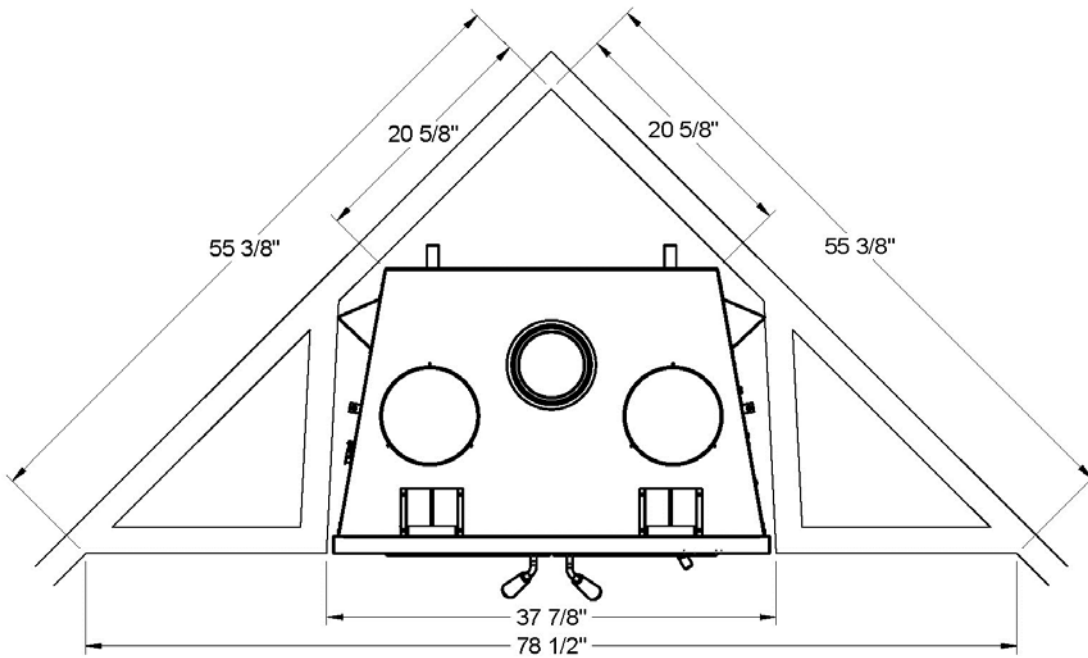

Figure 11

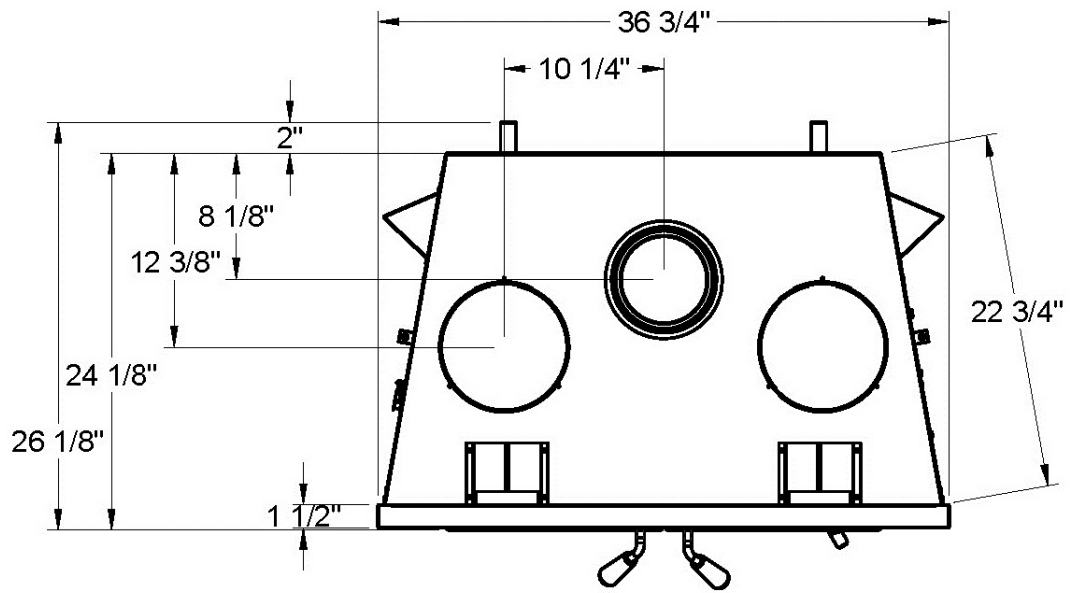

Figure 12

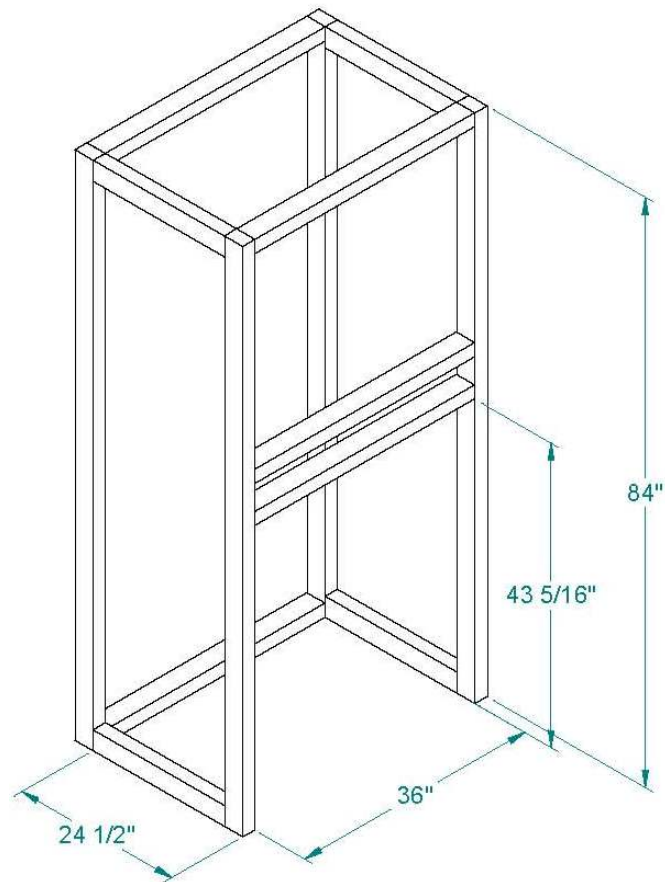

Figure 13

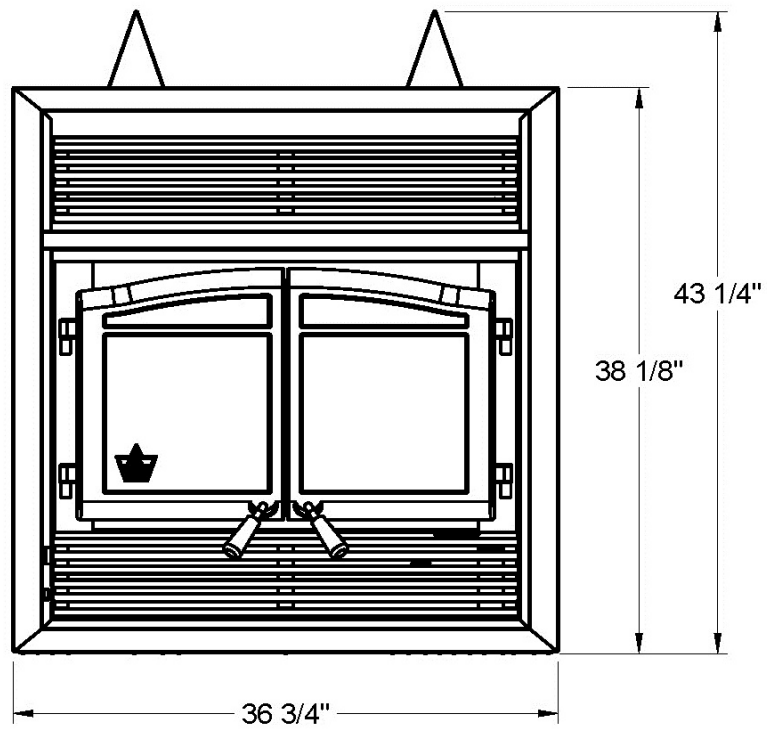
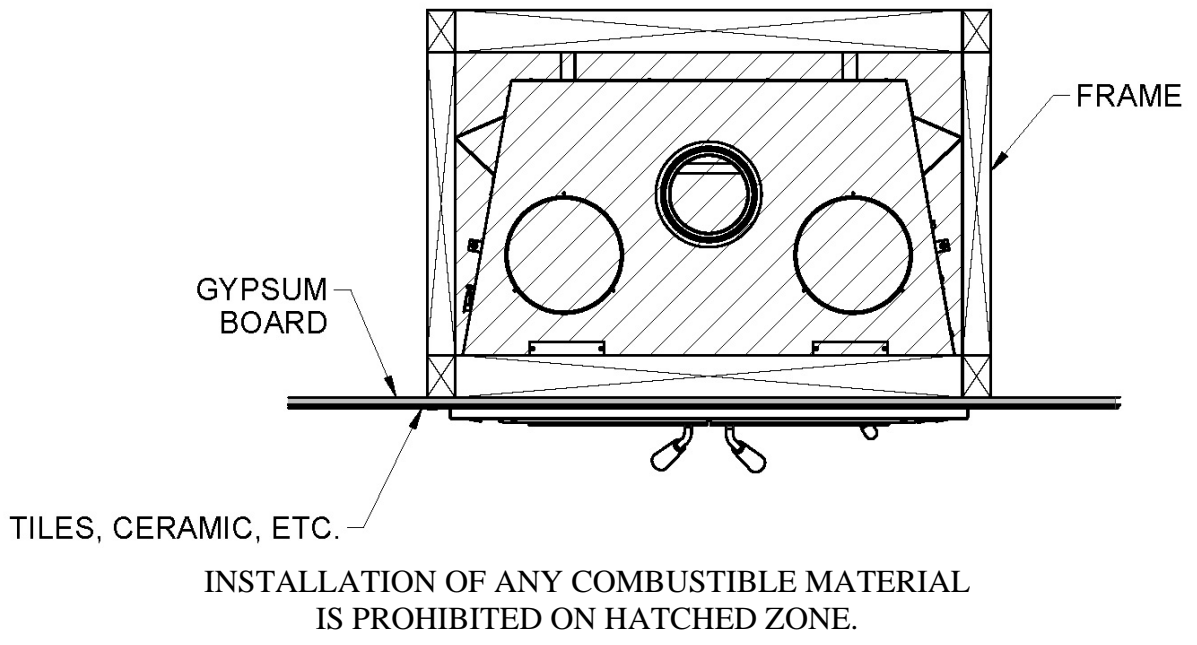

Figure 14

INSULATED CHASE CONSTRUCTION

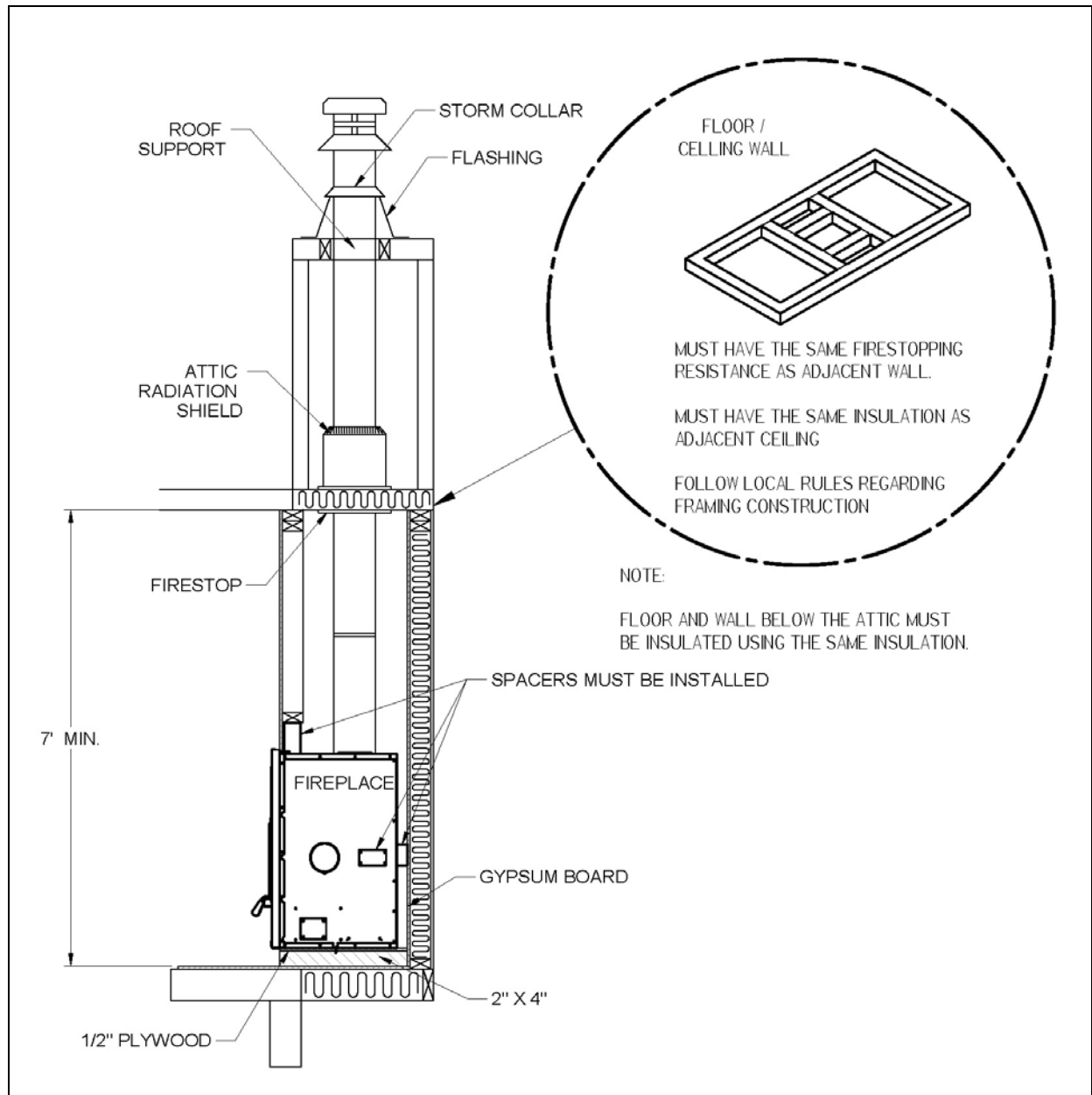

Figure 15

- **Facing**

1. Materials directly in contact with the faceplate of the fireplace, especially the vertical and horizontal surround, must be non-combustible and have the minimal dimensions as shown on figure 16.
2. Non-combustible materials such as brick, stone or ceramic tile may project in front of and onto the fireplace decorative frame.

Caution: Materials must be installed so that the faceplate may be removed after the installation. The faceplate is designed to overlap the material surrounding the fireplace. If the material is thicker, use a faceplate gauge for positioning and make sure that the faceplate can be removed after it has been installed.

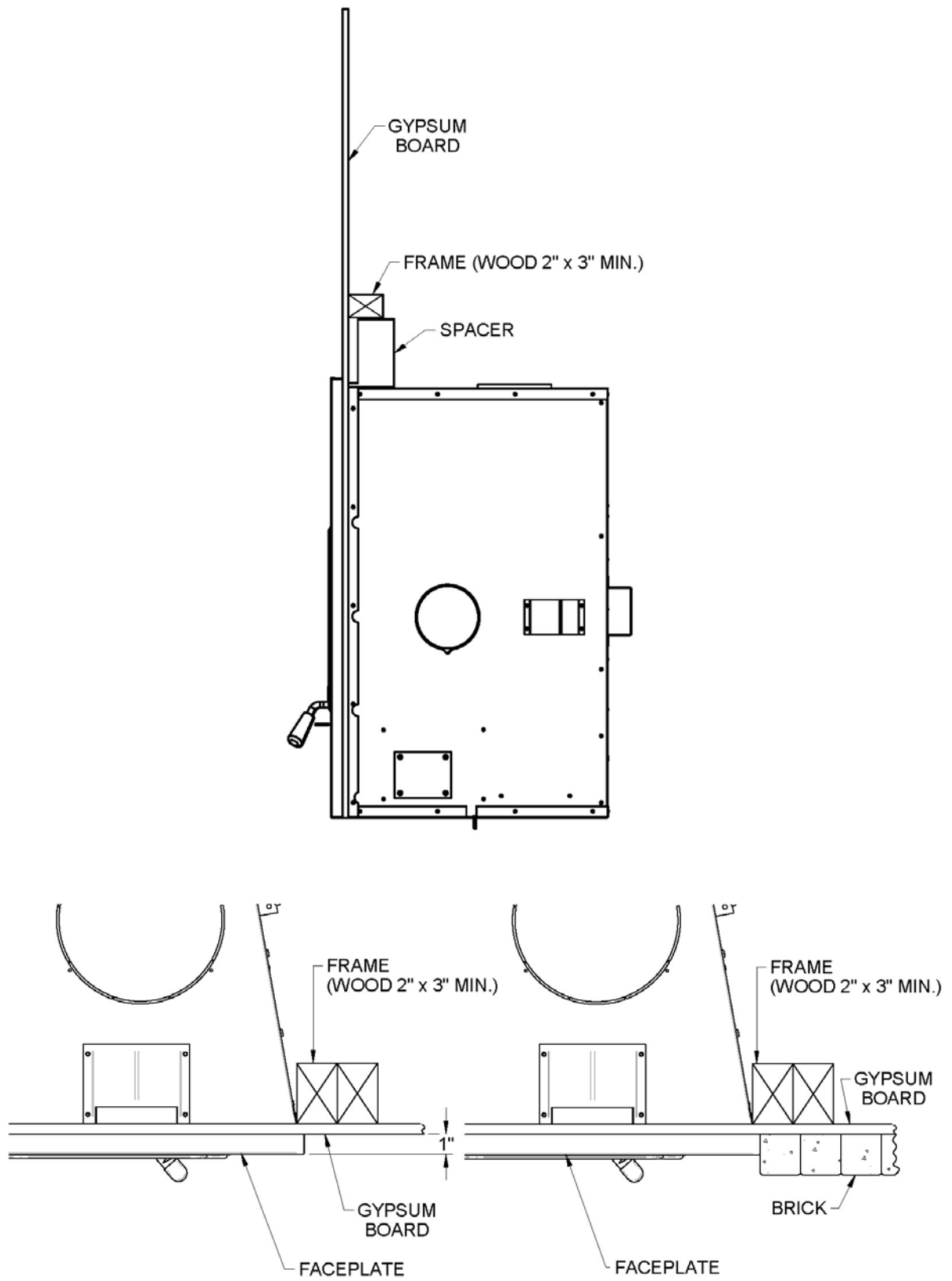

Figure 16

- **Combustible shelf**

To install any combustible shelf, refer to figure 17 for a safe installation. For example, a shelf with a 6'' depth (152 mm) must be installed at least 50'' (127 cm) above the base of the fireplace. Different shelf dimensions are listed in figure 17 in order to facilitate installation. However, the minimum depth of the shelf is 6'' or less. If the depth of the shelf is not listed in the table, add 44'' (112 cm) to the depth of your shelf to obtain the safe positioning of your shelf. For example, for a 9'' shelf, the safe positioning would be 53'' (44 inches + 9 inches).

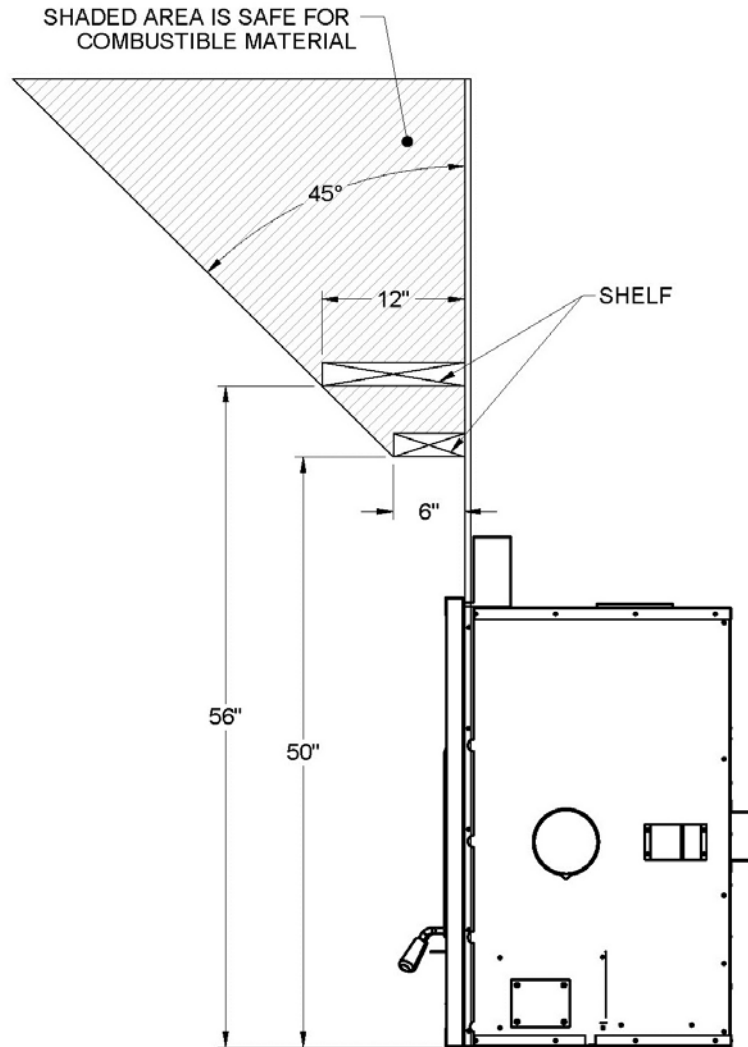

Figure 17

SHELF POSITIONING	
SHELF DIMENSION	SHELF POSITION
<i>6" / 152 mm</i>	<i>50" / 127 cm</i>
<i>8" / 203 mm</i>	<i>52" / 132 cm</i>
<i>10" / 254 mm</i>	<i>54" / 137 cm</i>
<i>12" / 305mm</i>	<i>56" / 142 cm</i>

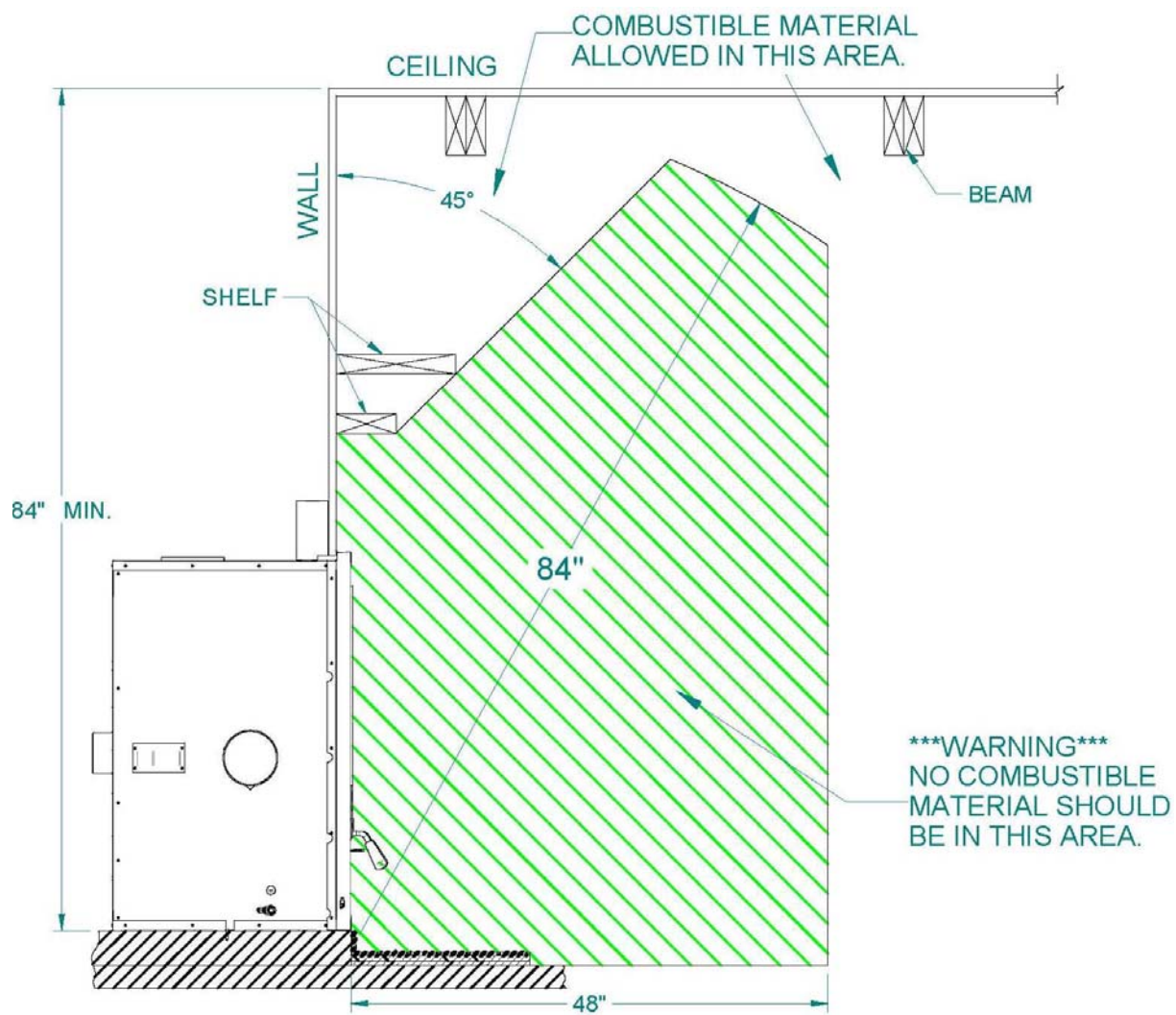

Figure 18

2.4.4 Blower connection

The fan will come on as soon as the fireplace reaches its minimum start temperature. Have the wiring installed by a qualified electrician. Connect the wires from the power outlet to the terminal block, making sure that the white wire matches the white wire on the terminal. Connect the black wire with the black wire of the terminal block. The ground (green or skinned wire) must be attached to the fireplace metal frame.

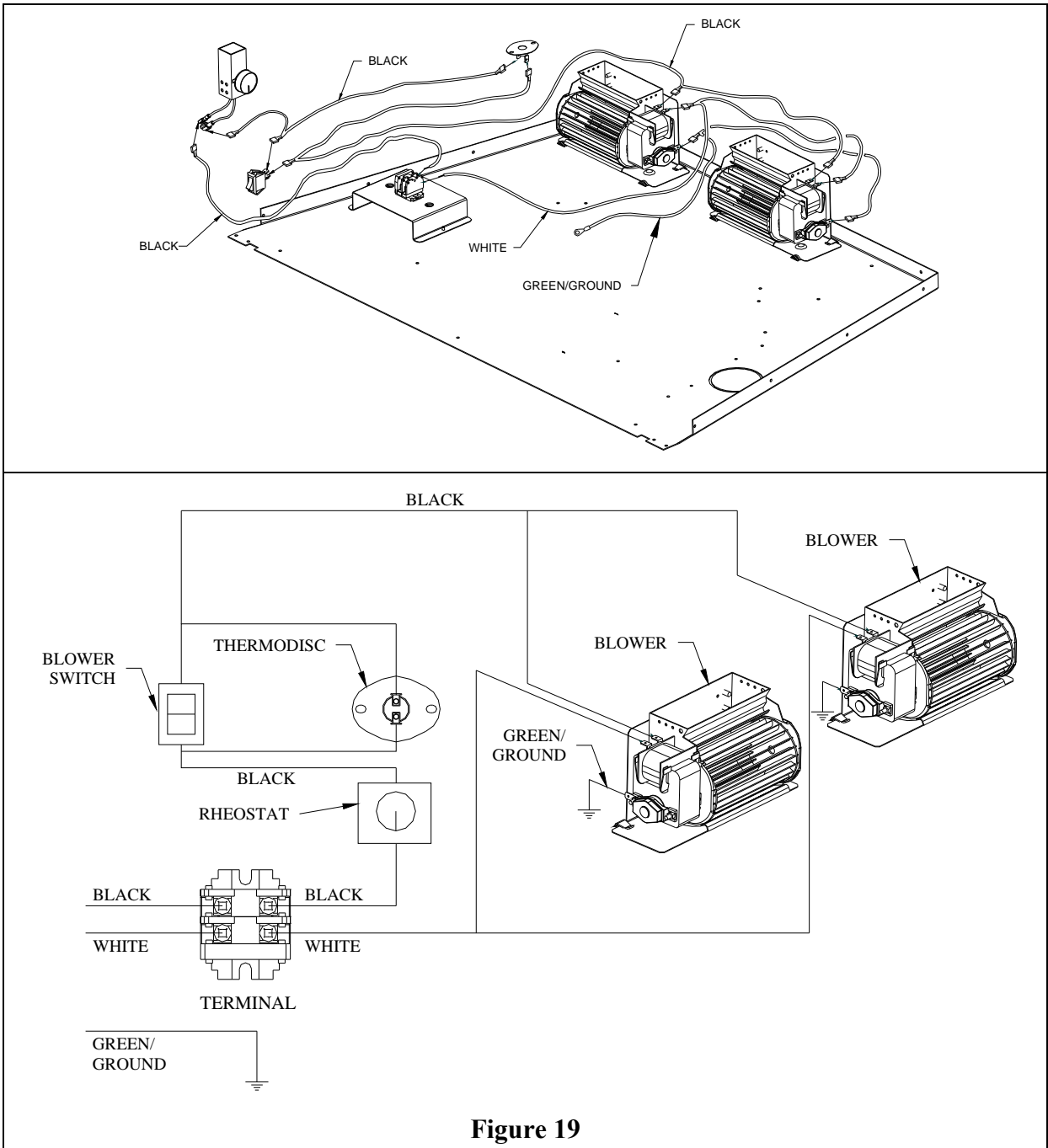

Figure 19

2.5 HOT AIR DUCTING INSTALLATION

Different hot air ducting systems can be installed with the MONACO:

- Gravity kit
- Forced air kit

2.5.1 Gravity Kit

The kit includes:

- 2 x hot air outlets (grilles and frames);
- 2 x 90° elbows with brackets;
- 1 deflector.

The gravity kit allows you to block the upper fireplace louver. To do so, follow the steps below:

- Remove the upper louver from the fireplace;
- Install the deflector as shown on figure 20;
- Put the upper louver back into place.

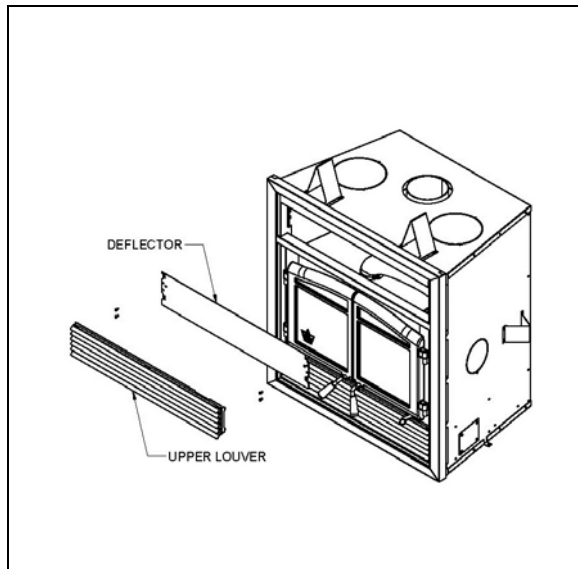

Figure 20

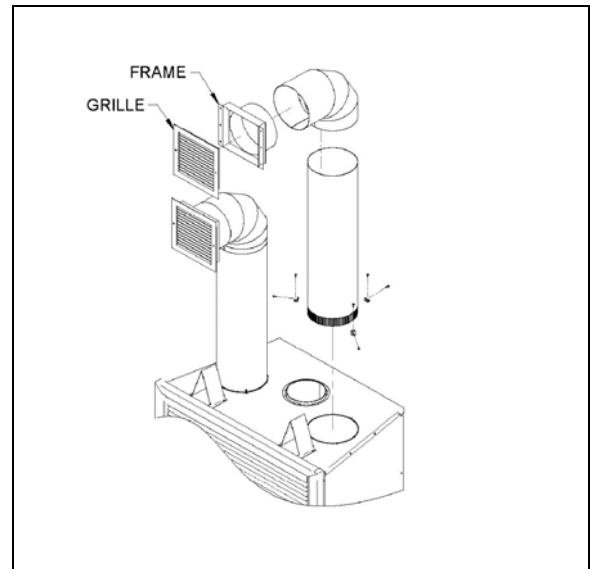

Figure 21

The safety rules for hot air ducting gravity kit installations are the following:

- Minimum height* 68" (1.7 m)
- Maximum length 10' (3m) (see figure 22)

*The minimum height of the hot air ducting must be measured from the floor to the top of the hot air grilles.

The hot air grilles can be installed in the same room as the fireplace, or one or both of the grilles can be installed in adjacent or upper rooms. Installing the ducts at different elevations will tend to exhaust more heat out of the higher grilles (figure 23).

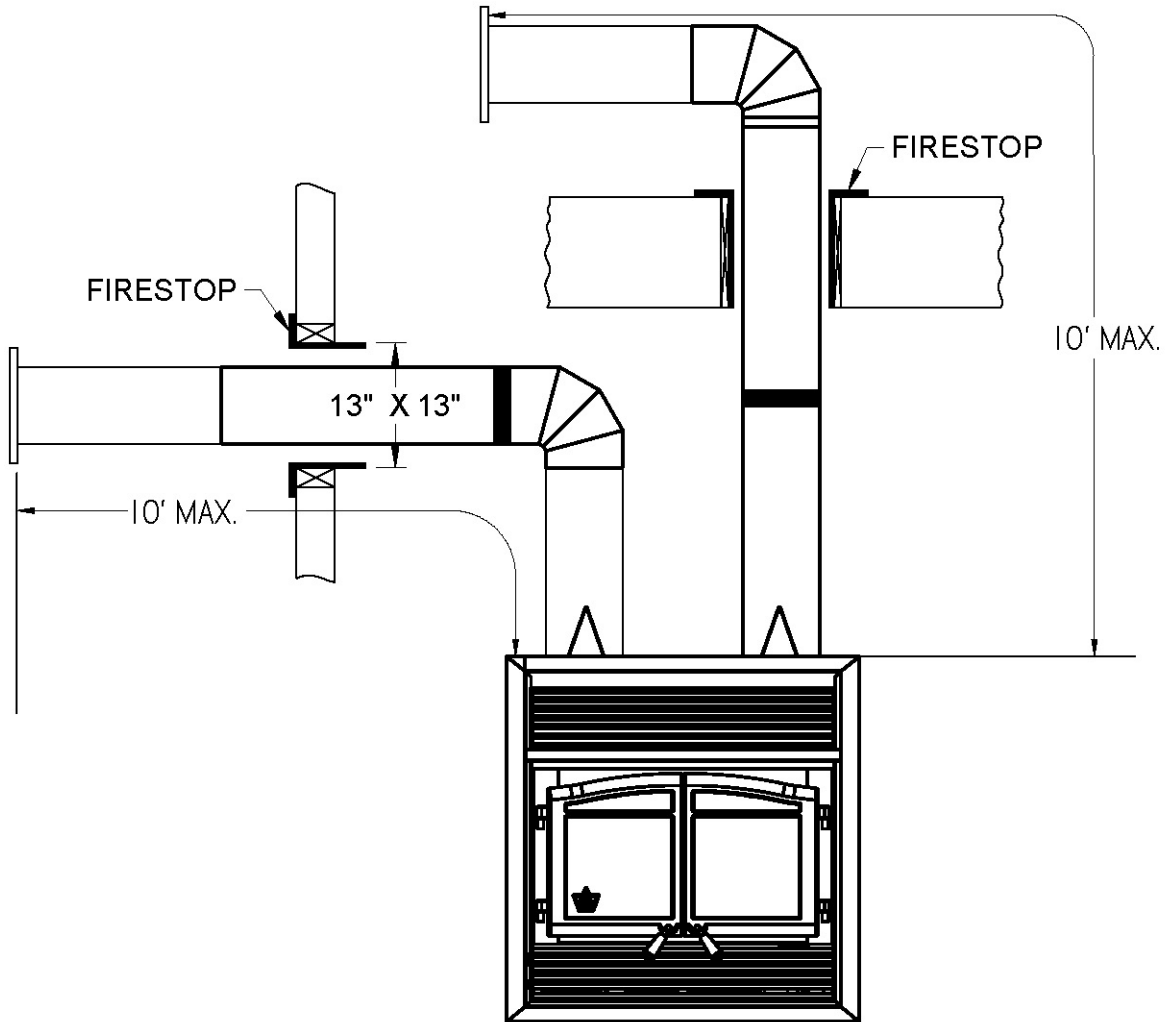

Figure 22

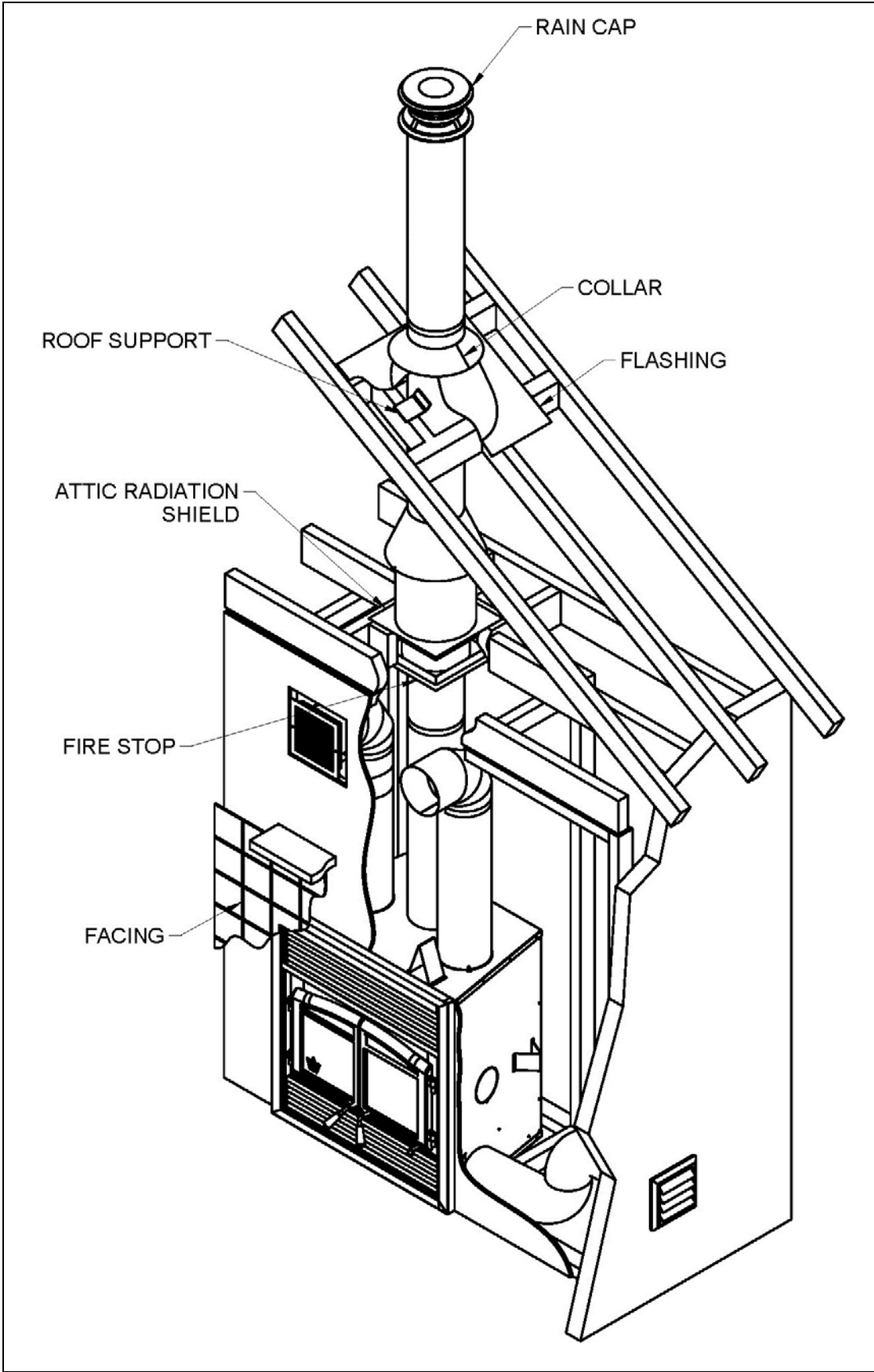

Figure 23

The duct system must be installed respecting the following:

1. Remove the plates closing up the 8" dia. holes on top of the fireplace. Then, cut the insulation in order to obtain two 8" dia. openings. Insert the ducting into each opening and fix it in place using the 6 steel brackets supplied (3 for each duct).
2. Maintain at least a 2" (50 mm) clearance between the ducts and the firestop; the required hole size for the hot air grilles (outlet) is 8¼" × 8¼" (210 mm × 210 mm).
3. The maximum number of elbows in a run of duct is two.
4. Maintain at least 10" (254 mm) clearance from the outlet grille framing to a combustible ceiling, side wall or mantel.
5. When passing through a combustible wall or floor, a firestop must be installed at the wall or floor penetration. The hole size must be in accordance with the duct manufacturer's instructions.
6. Do not connect the hot air ducts to a central heating system. Malfunction of the heating system's fan will cause the fireplace to overheat.
8. Do not use insulated flexible ducts as they may overheat.
9. Do not use tees or any other components than the ones specifically listed here.
10. All ducts must extend upwards or horizontally. **Never route the ducting downwards.**
11. The hot air outlet grilles must be installed with the louvers pointing downwards in order to prevent overheating adjacent ceilings.
12. Always install the two outlet grilles when using the hot air outlet kit and blocking the upper louver of the fireplace.

2.5.2 Central Forced Air Kit (Not tested under EPA certification)

The knock-outs provided on the back and on the sides of the MONACO allow the connection of insulated flexible pipe which enables you to heat adjacent rooms up to 50 feet from the fireplace (see figure 26).

The ducting system must be installed as described below:

- A) Remove the knock outs at the back and/or the side of the fireplace and cut the insulation around the hole. Fix the adapter into place with screws. You can use more than one outlet on the fireplace (figure 24);
- B) Attach the 5" flexible pipe, using the collars provided. **Important:** Make sure that the plastic wrapping around the flexible pipe is not in contact with the fireplace;
- C) Attach the flexible pipe to the fan's air inlet using the collars provided (figure 25);

- D) Attach a flexible pipe to the fan's air outlet and route the flexible pipe to the chosen location. The ducting system can be installed either in an upper room or in a lower room;
- E) At that point, the flexible pipe can be attached to any air distribution grille.
- F) Make the electrical connections to the PC Board as explained with the forced air kit owner's manual.

Since the forced air kit requires electricity, make sure that the connections to the fan have been made according to the local codes and comply with their requirements (see instruction provided with the kit).

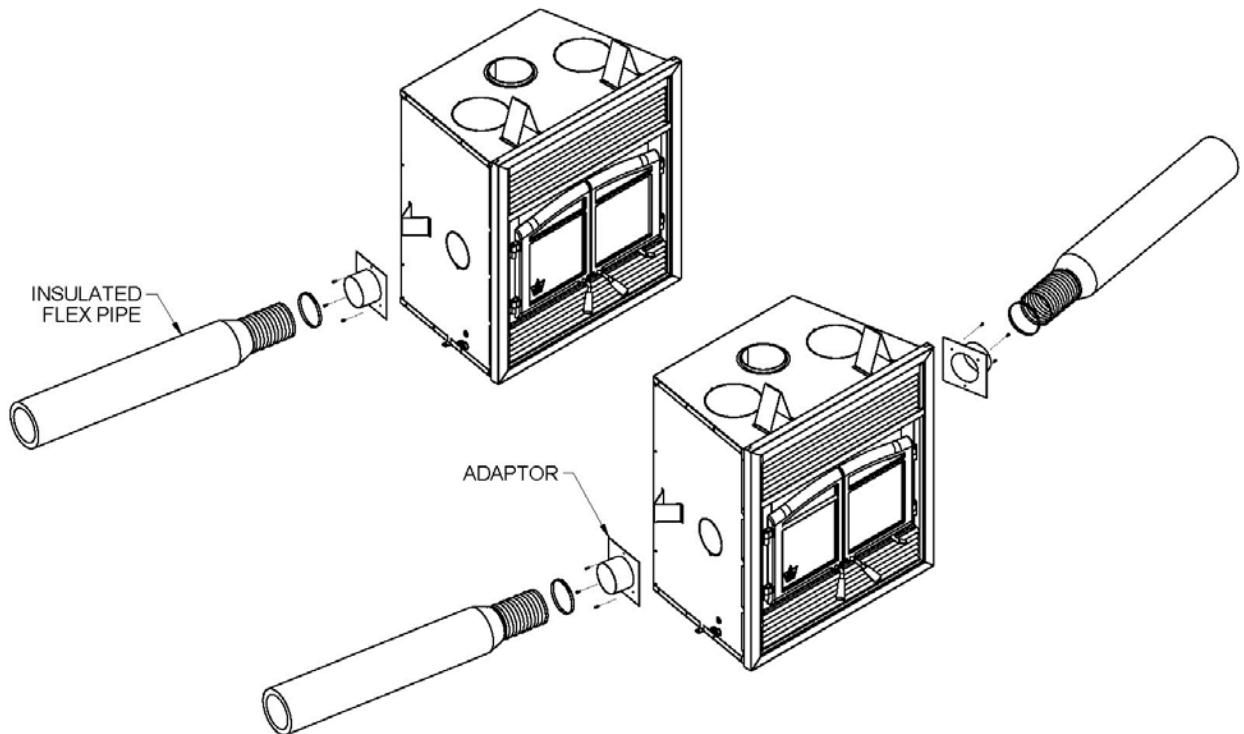

Figure 24

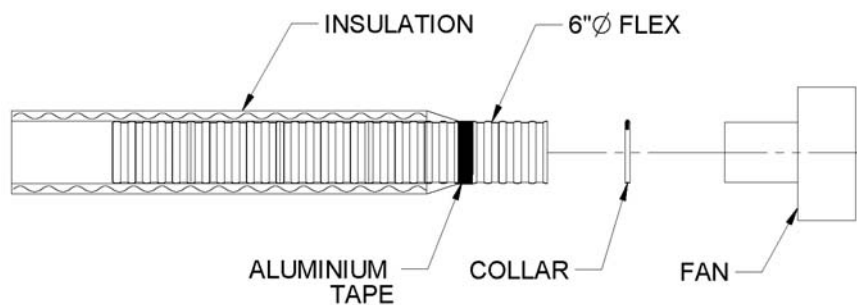

Figure 25

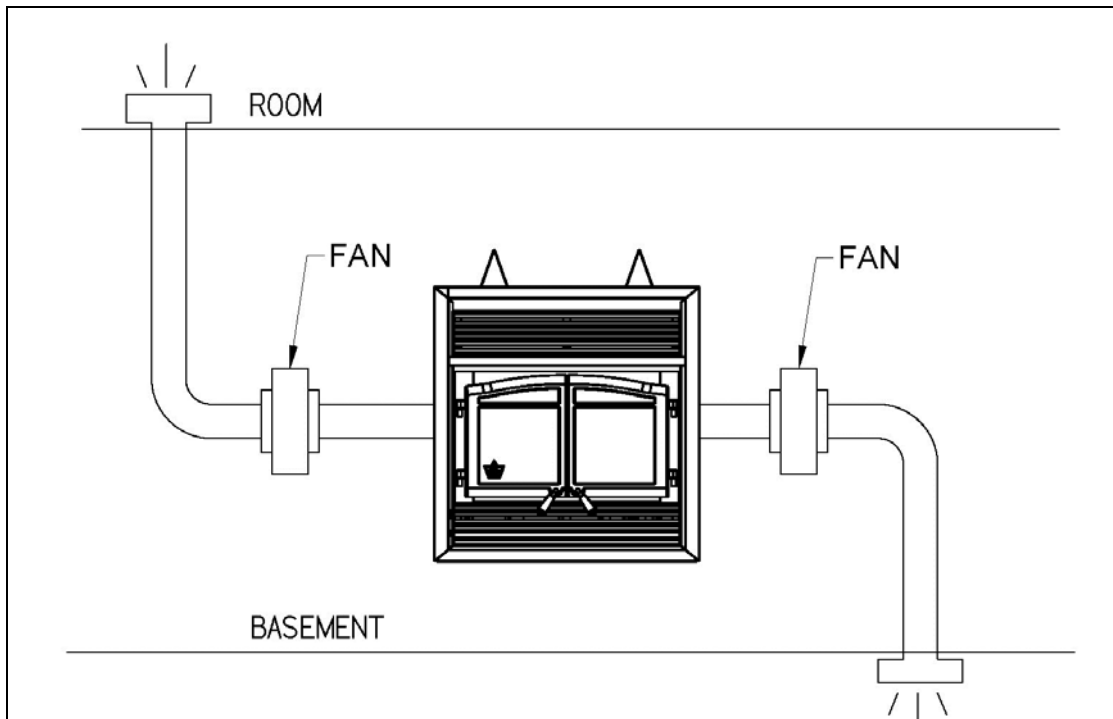

Figure 26

2.6 **FRESH AIR KIT (OPTIONAL)**

During operation, the fireplace requires fresh air for combustion and draws air out of the house. It may starve other fuel burning appliances such as gas or oil furnaces. As well, exhaust fans may compete for air, causing negative pressure in the house, resulting in smoke entering the house from the fireplace. This situation is aggravated in modern airtight houses. To overcome this problem, we strongly recommend that you **install fresh air kit (not included)**. Check with local authorities having jurisdiction in your area, it may be mandatory.

2.6.1 **Outside Air Installation**

The fresh air kit may be installed according to the following requirements:

- A) Insulated duct length should be sufficient to avoid condensation.
- B) The outside wall termination must not be installed more than 10 ft. (3 m) above the base of the fireplace.
- C) The fresh air must come from outside the house. The air intake must not draw air from the attic, from the basement, or from a garage.
- D) The outside wall termination should be installed where it is not likely to be blocked by snow or exposed to extreme wind and away from automobile exhaust fumes, gas meter and other vents.
- E) The outside termination may be installed above or below floor level.
- F) If more fresh air is needed (airtight house or conduit exceeding 10 ft or 3 m), two intakes may be installed, providing twice the quantity of incoming fresh air; you may also increase both conduits to 4 inches, with the use of a 3 to 4 inch adaptor, again increasing substantially the quantity of incoming fresh air.

The fresh air kit contains the following components:

- | | |
|-----------------------------|-------------------------------|
| 1- A 3" flex adapter; | 4- Plate for room air intake; |
| 2- 2 pipe clamps; | 5- 6 screws; |
| 3- An outside air register; | 6- 3" to 4" adaptor. |

To complete the fresh air kit installation, you will need a 3" insulated flexible pipe. Use the length required for your installation while respecting the maximum length of 10 ft. (3 m).

Make a 3 1/4" (83 mm) hole in the outside wall of the house at the chosen location. From outside, place the outside air register in the hole (open side down) and fasten the register to the wall, with screws as shown (see figure 27). Place the insulated pipe over the register tube and over the fireplace's outside air connector (see figure 28). At each end, carefully pull back the insulation and plastic cover, exposing the flexible pipe. Attach the flexible pipe using pipe clamps. For a better seal, you may also use aluminum tape. Wrap the tape around the joint between the flexible pipe and the air inlets. Carefully push the insulation and plastic cover back over the pipe. Fix the plastic in place using aluminum tape.

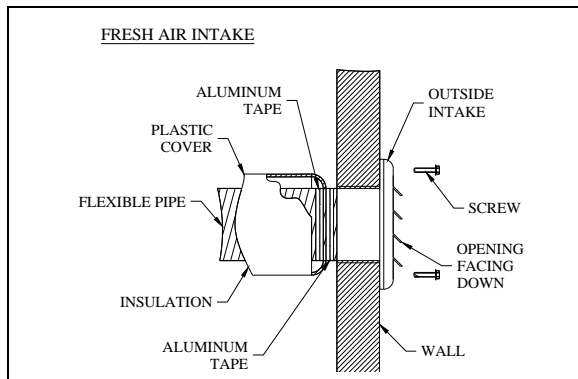

Figure 27

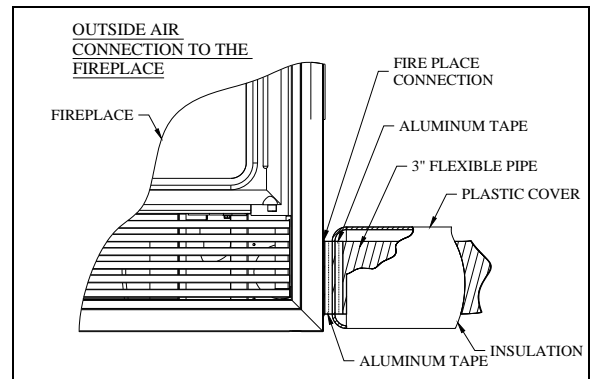

Figure 28

- 1) Remove the bottom louver
- 2) Seal the room air intake located on the right side by installing the plate over the opening. Use the two clips on the right side and two screws on the left side as in figure 29 to secure the plate.
- 3) Select which air inlet you wish to use figure 30 (you may use more than one) and either remove the cover figure 31 (side inlet) or remove the knock-out (bottom and rear inlets).
- 4) Install the adapter over the selected inlet with the 4 screws included (figure 32).
- 5) Secure a 3" insulated flexible conduit (not included) to the stove's adapter and the outside termination (not included) with the 2 adjustable straps (not included) figure 27, 28 & 33.

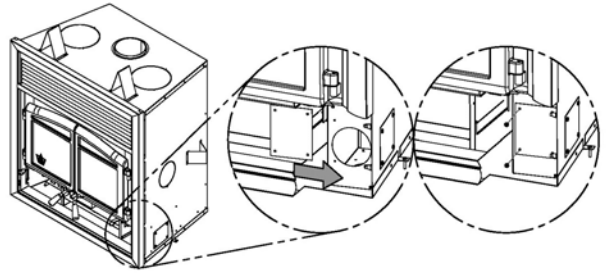

Figure 29

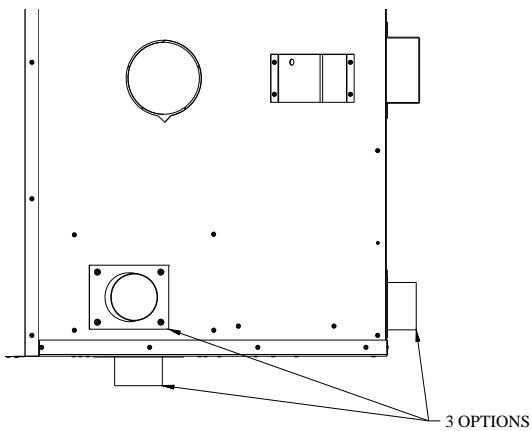

Figure 30

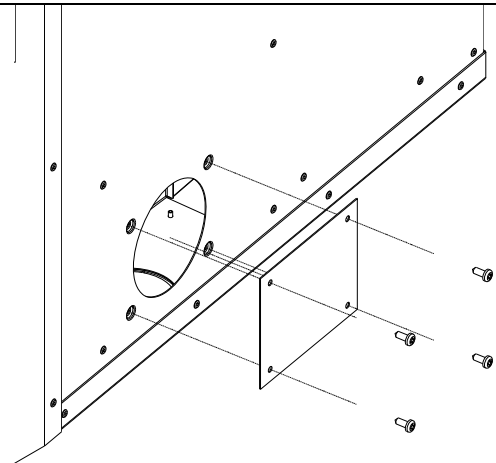

Figure 31

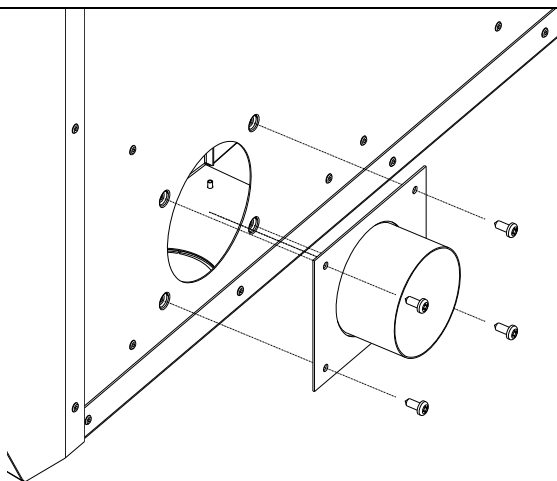

Figure 32

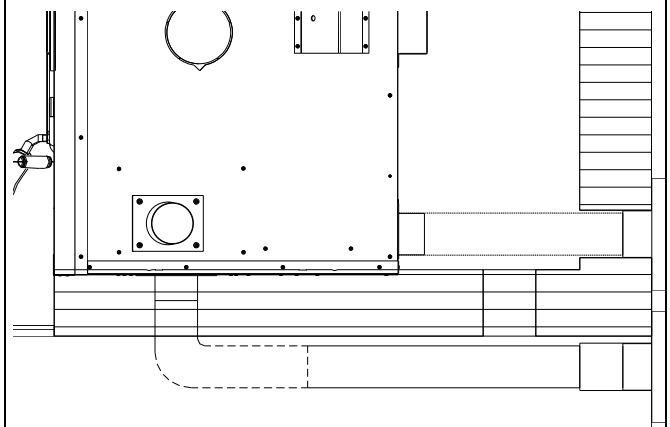

Figure 33

2.8 DOOR ALIGNMENT

To adjust the door positioning and spacing, loosen the hinge screw and pivot the hinge until the door is in the correct position. To tilt the door, lock in place one of the two hinges and pivot the other. The door will tilt to one side or the other depending on the direction the hinge is pivoted. For the door to be straight, both hinges must be aligned along the same axis.

If the door hinges are misaligned, it will tilt. It is therefore recommended to align them. Once the ideal position has been achieved, lock the hinges in place by tightening the hinges screws.

Adjust the pressure on the gasket using the centre adjustment screw located at the bottom of the combustion chamber. To check the pressure applied, place a slip of paper between the door and the face, and pull gently. You should feel a slight resistance.

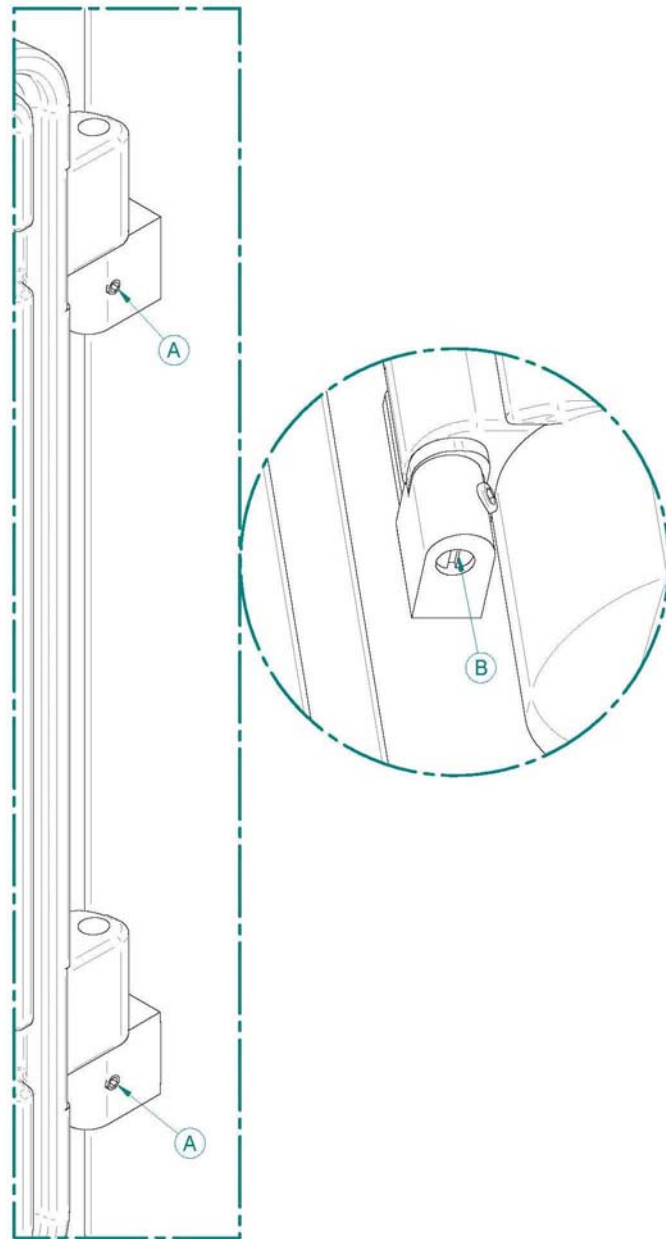

Figure 35

3. THE CHIMNEY

3.1 CHIMNEY INSTALLATION NOTES

1. If possible, install an interior chimney as it will provide better performance. In areas with continuous temperatures below -18°C (0°F), the use of an exterior chimney increases the likelihood of operating problems such as low draught, high rate of creosoting, and poor start-up characteristics. Exterior chimneys are also prone to down-drafting and flow reversal. Installations, which are located on lower floors in the house, such as in a basement, in combination with outside chimney, are especially prone to flow reversal.
2. The MONACO is listed only with chimney systems described in table 2.
3. A chimney venting a fireplace shall not vent any other appliance.
4. The minimum chimney system height is 15 ft. (4.6 m).
5. All chimney installations must include at least one support. Reducing the amount of chimney weight on the fireplace will help avoid the noise created when the fireplace expands. This can be achieved by having the chimney supported by the supports. The maximum chimney length that should be supported by the fireplace is 9 ft. (2.75 m) for 2" Solid Pack Chimney, 12 ft. (3.7 m) for 1" Solid Pack Chimney, and 26 ft. (8 m) for AC Triple Wall Chimney.
6. The chimney must extend at least 3 ft. (1 m) above its point of contact with the roof and at least 2 ft. (0.6 m) higher than any wall, roof or building within 10 ft. (3 m) of it (Figure 36).
7. If the chimney extends higher than 5 ft. (1.5 m) above its point of contact with the roof, it must be secured using a roof brace.
8. A rain cap must be installed on top of the chimney. Failure to install a rain cap may cause corrosion problems.
9. Cut and frame square holes in all floors, ceilings, and roof that the chimney will go through to provide a 2" (50 mm) clearance between the chimney and any combustible materials. Do not fill this 2" space with insulation or any other combustible material.
10. Portions of the chimney which may extend through accessible spaces must be enclosed to avoid contact with combustible materials or damage the chimney.

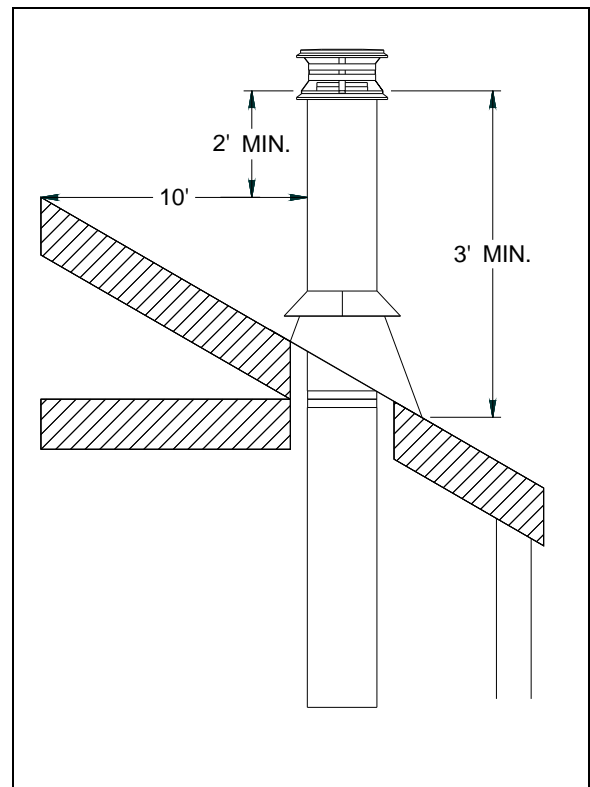

Figure 36

3.2 CHIMNEY INSTALLATION INSTRUCTIONS

1. Cut and frame the holes in the ceiling, floor and roof where the chimney will pass and install rafter protectors (see figure 37). Use a plumb bob to line up the center of the holes. Make sure that the size of the floor and ceiling holes are in accordance with the chimney manufacturer's instructions.

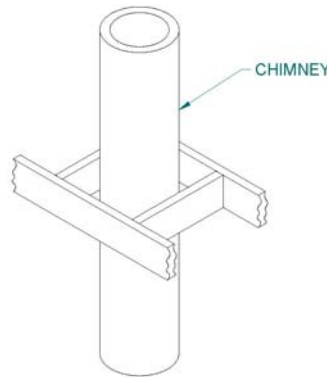

Figure 37

2. From below, install a firestop supplied by the chimney manufacturer in each ceiling/floor separation through which the chimney will pass. At the attic level, install an attic radiation shield from above (see figure 38).
3. Follow the chimney's manufacturers' instructions and place the first chimney length on the fireplace. For all chimneys, you must use an anchor plate supplied by the chimney manufacturer before installing the first chimney length (see figure 38). Continue installing chimney lengths making sure to lock each length in place.
4. Every time the chimney passes through a ceiling or a wall, install the appropriate firestop. When you reach the desired height, install the roof support. (Refer to instructions included with the support.).
5. Then, put the roof flashing in place and seal the joint between the roof and the flashing with roofing pitch (see figures 38). For sloping roofs, place the flashing under the upper shingles and on top of the lower shingles. Nail the flashing to the roof, using roofing nails.
6. Place the storm collar over the flashing, and tighten it with the bolt supplied. Finally, seal the joint between the storm collar and the chimney, using silicone caulking.
7. Install the chimney cap.
8. When a ventilated roof flashing is installed, precautions are to be taken not to caulk or seal the ventilating openings.

EXAMPLE OF TYPICAL CHIMNEY INSTALLATION

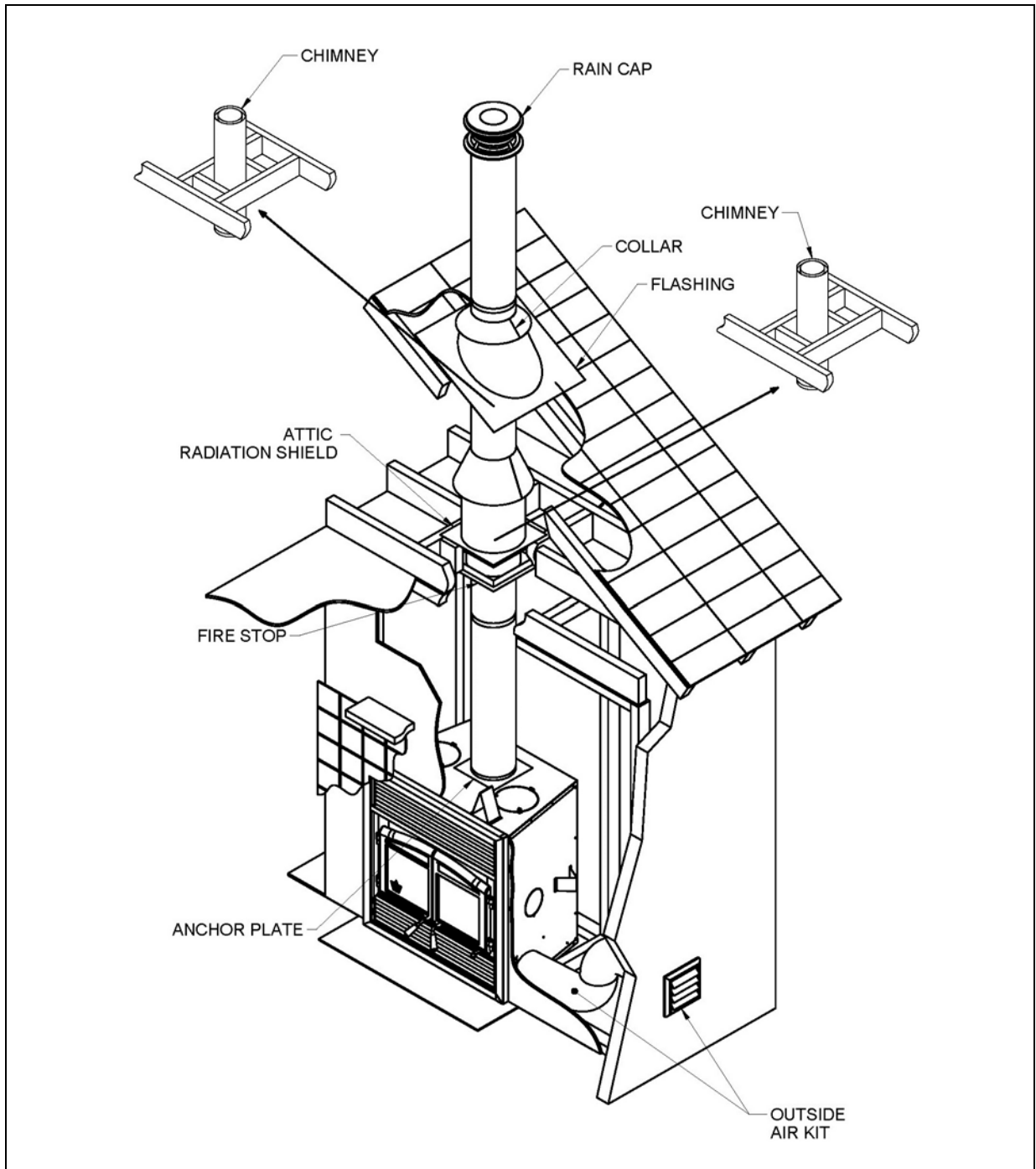

Figure 38

When you build a combustible chase enclosure for chimney sections above the roof, refer to the chimney manufacturer for clearances to combustible materials.

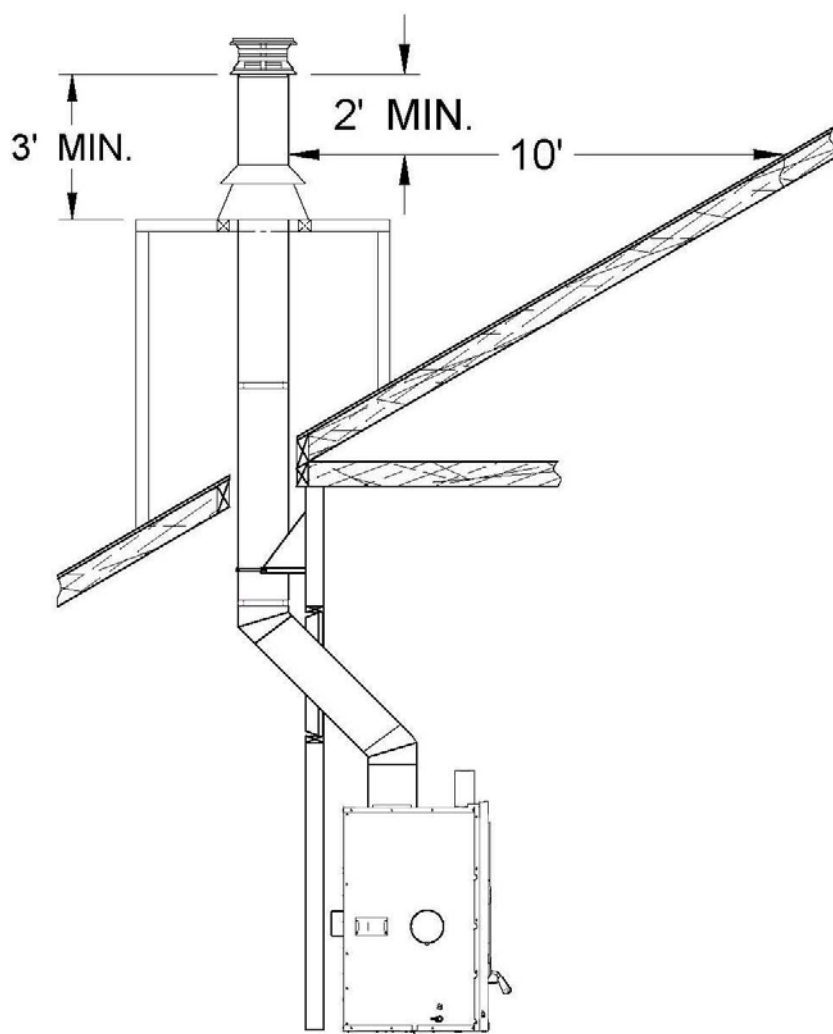

Figure 39 – Example of a combustible chase enclosure installation above the roof

3.3 OFFSET CHIMNEY INSTALLATION

The minimum system height when using elbows is:

Fireplace model	MONACO
Chimney model	All models
Vertical installation	15 ft. (4.6 m)
Two (2) elbows	15 ft. (4.6 m)
Four (4) elbows	17 ft. (5.2 m)

Table 1

After reaching the location requiring the elbow, proceed as follows:

1. Install the first elbow; turn it in the required direction. Secure it to the chimney according to the chimney manufacturer's instructions. In many cases, it is recommended to secure connections with three (3) ½" (12 mm) metal screws.
2. Install the necessary chimney lengths to achieve the required offset. Lock the chimney lengths together according to the chimney manufacturer's instructions. In many cases, it is recommended to use three (3) ½" (12 mm) screws. If the offset length is made of two (2) chimney lengths or more, many chimney manufacturers may require that you use an offset or roof support halfway up the offset. If penetrating a wall, install a wall radiation shield supplied by the chimney manufacturer (see figures 40 & 41).
3. Use another elbow to turn the chimney vertically. Secure the elbow.
4. Use a plumb bob to line up the centre of the hole. Cut a hole for the chimney in the ceiling/floor. Frame this hole as described previously.
5. From below, install a firestop supplied by the chimney manufacturer (see figure 38).
6. A support must be used on the first 15' section (4.6 m).
7. Continue with the regular installation.

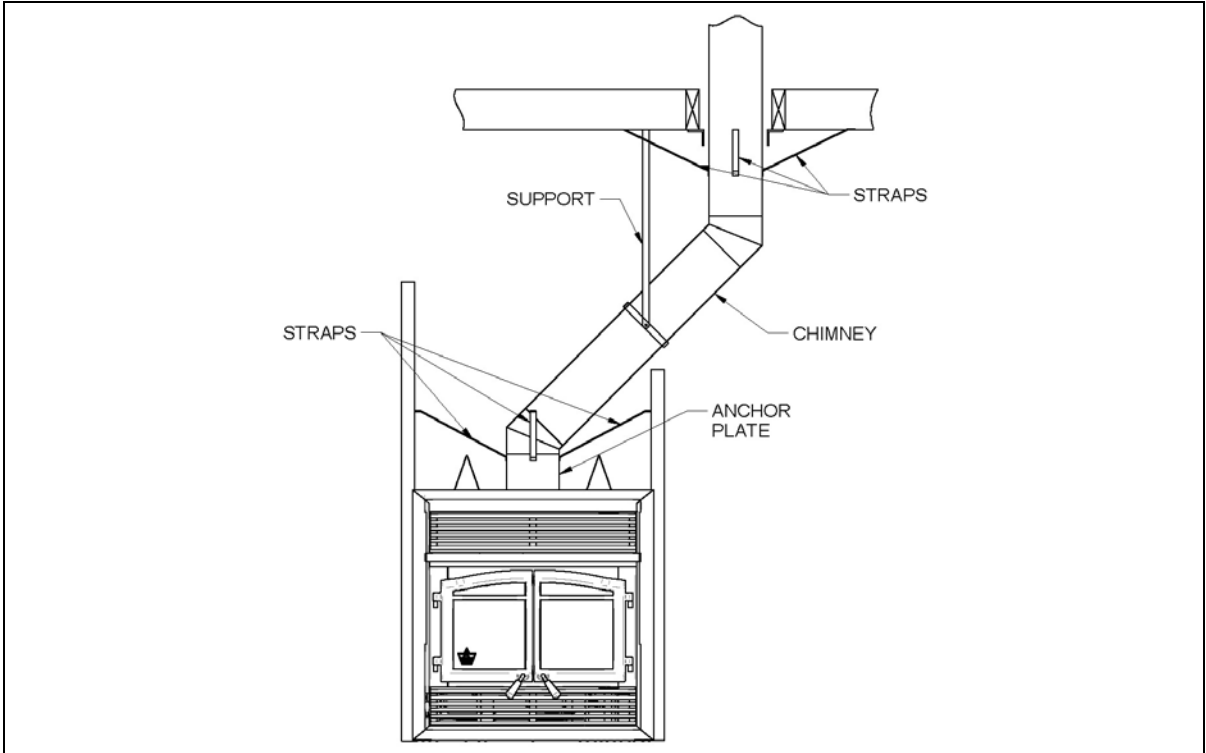

Figure 40

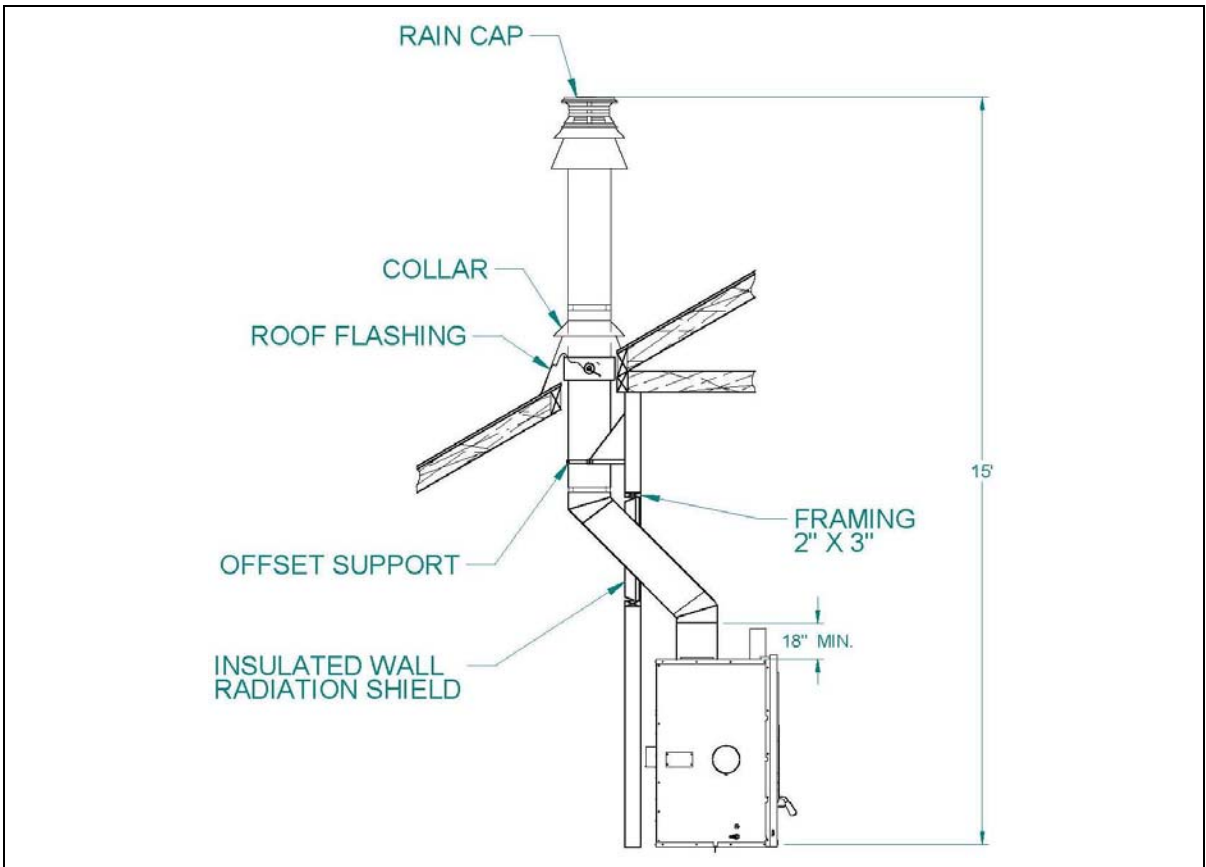

Figure 41

TABLE 2 - LISTED CHIMNEYS FOR YOUR MONACO

CHIMNEY MANUFACTURER	BRAND	TYPE	INNER DIAMETER
Selkirk	Ultra-Temp (UT)	1" Solid Pack	6" (15 cm)
Selkirk	Super Pro (SPR)	1" Solid Pack	6" (15 cm)
Selkirk	Super Vent (JSC)	1" Solid Pack	6" (15 cm)
Selkirk	Hart & Cooley (TLC)	1" Solid Pack	6" (15 cm)
Selkirk	Sure-Temp (ST)	1" Solid Pack	6" (15 cm)
Selkirk	CF Sentinel (CF)	2" Solid Pack	6" (15 cm)
Selkirk	Super Pro 2100 (ALT)	2" Solid Pack	6" (15 cm)
Selkirk	Super Vent 2100 (JM)	2" Solid Pack	6" (15 cm)
Selkirk	UltimateOne	1" Solid Pack	6" (15 cm)
Security Chimney	ASHT+	1" Solid Pack	6" or 7" (15 or 18 cm)*
Security Chimney	S-2100 +	2" Solid Pack	6" or 7" (15 or 18 cm)*
Simpson Dura Vent	Dura Tech	1" Solid Pack	6" (15 cm)
Simpson Dura Vent	Dura Plus HTC	2" Solid Pack	6" (15 cm)
Simpson Dura Vent	Dura Plus	AC Triple Wall	6" (15 cm)
ICC	Excel 2100	1" Solid Pack	6" (15 cm)
Metal Fab	Temp Guard	1" Solid Pack	6" (15 cm)
American Metal	HSS	AC Triple Wall	6" (15 cm)
American Metal	HS	AC Triple Wall	6" (15 cm)
Olympia Chimney	Ventis	1" Solid Pack	6" (15 cm)
FMI (U.S.A. only)	AC	AC Triple Wall	6" (15 cm)

*This fireplace may be installed with a 7-inch chimney of the same type as the ones listed in the above table, provided that a 6" to 7" insulated increaser (see figure 42, parts C and D), supplied by the chimney manufacturer, is installed for the transition between the 6-inch anchor plate(see figure 42 part A) wich can be secured with screws (see figure 42 part B) and the 7-inch flue. For Security Chimneys, the part number is 6AW7.

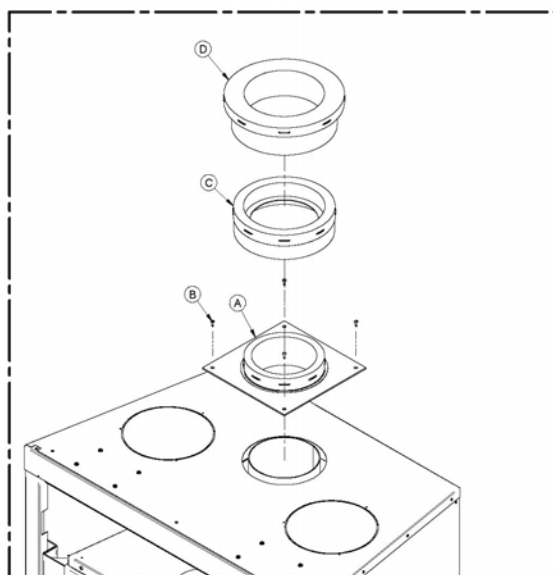

Figure 42

TABLE 3 – LIST OF MANDATORY COMPONENTS

CHIMNEY MANUFACTURER	MANDATORY COMPONENTS	TYPE/BRAND
Selkirk	<ul style="list-style-type: none"> • Ventilated roof flashing. • Must have rafter protectors at the roof level if the chimney is enclosed at the attic level (see section 4). 	Ultra-Temp (UT), Super Pro (SPR), Super vent (JSC), Hart & Cooley (TLC), Sure-Temp (ST)
Security Chimney	<ul style="list-style-type: none"> • Rafter protector at the roof level if chimney is enclosed at the attic level (see section 4). • Requires insulated attic radiation shield unless chimney is enclosed at the attic level. • Requires the use of a 6AW7 (Solid pack 1") adapter for a ASHT+ of 7". • Requires the use of a 6AW7 and a 7UCA adapter for the S-2100 of 7". 	1" Solid Pack: ASHT+, 2" Solid Pack : S-2100
Simpson Dura-Vent	<ul style="list-style-type: none"> • Ventilated roof flashing. • Rafter protector at the roof level if chimney is enclosed at the attic level (see section 4). 	1" Solid Pack : Dura Tech
ICC	<ul style="list-style-type: none"> • Ventilated roof flashing. • Rafter protector at the roof level if chimney is enclosed at the attic level (see section 4). 	Excel 2100
American Metal	<ul style="list-style-type: none"> • Chimney cannot be enclosed at the attic level. 	AC Triple wall HS, AC Triple wall HSS

WARNING: YOU MUST ALWAYS START WITH AN ANCHOR PLATE OF 6" FROM YOUR FIREPLACE EVEN WHEN YOU USE A 7" CHIMNEY. IN THIS CASE, YOU SIMPLY HAVE TO FIX AN ADAPTER (PART NUMBER 6AW7 IN THE CASE OF AN ASHT+) TO YOUR ANCHOR PLATE TO USE YOUR 7" CHIMNEY. FOR THE S-2100 OF 7", AN ADDITIONNAL ADAPTER (PART NUMBER 7UCA) NEEDS TO BE FIXED TO THE 6AW7. SEE SECURITY CHIMNEY FOR MORE INFORMATION.

3.4 ANGLED WALL RADIATION SHIELD

When passing through a combustible wall with the chimney at a 30° or 45° angle (30° or 45° in Canada and 30° only in the USA), an angled firestop or wall radiation shield provided by the chimney manufacturer must be installed. Only one is required. Follow the chimney manufacturer's installation instructions.

In cold climate locations, it is recommended that you use the insulated wall radiation shield since it will maintain the home's thermal barrier.

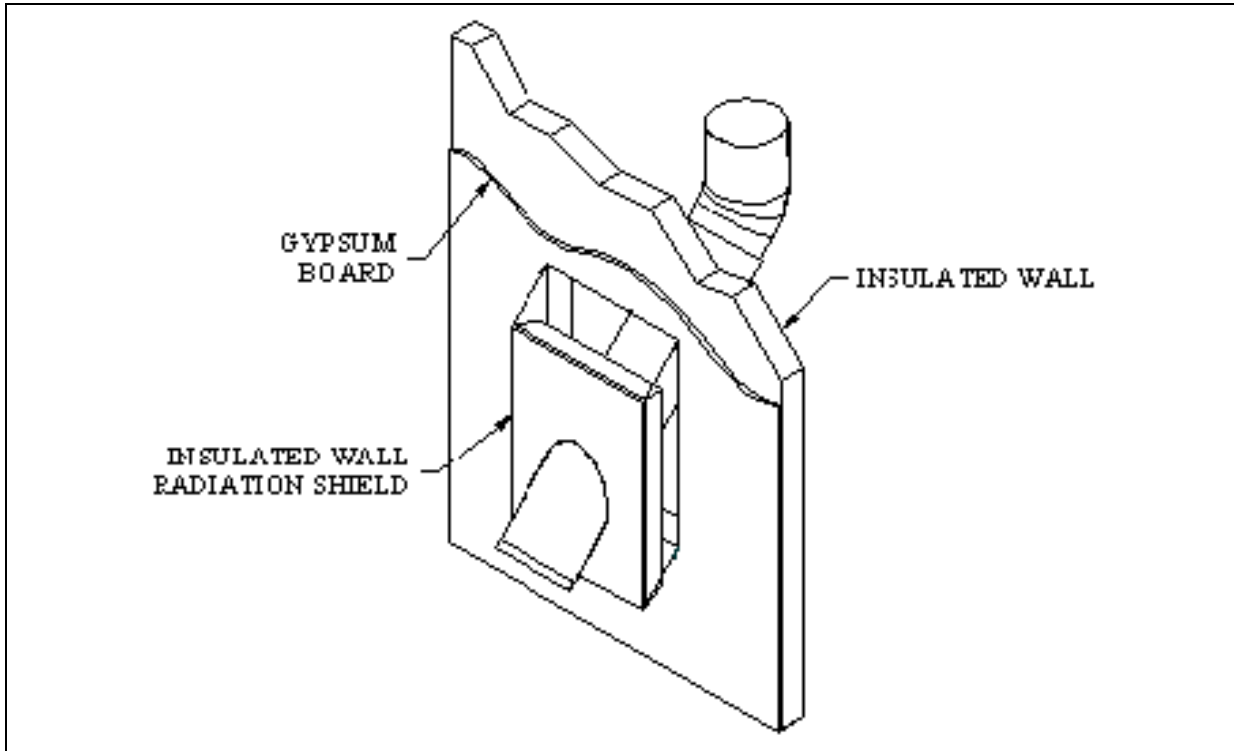

Figure 43

3.5 CHIMNEY SUPPORT INSTALLATION

Universal Roof Support

This support has three possible uses:

1. It must be used on a roof to support the chimney.
2. It may be used on a floor, ceiling or roof above an offset to support the chimney above the offset.
3. It may be used on a floor, ceiling or roof as a supplementary support.

For roof support installation, refer to the instructions provided with the support by the chimney manufacturer. Many manufacturers will provide the maximum height of chimney that can be supported by the support. Make sure you respect those parameters.

Universal Offset Support

This support is used to support the chimney above an offset. When the chimney offset is used to pass through a wall, this support may be used on the wall to support the chimney. For offset support installation, refer to the instructions provided with the support by the chimney manufacturer. Many manufacturers will provide the maximum height of chimney that can be supported by the support. Make sure you respect those parameters.

3.6 CHIMNEY CHASE AND MULTIPLE TERMINATIONS

For the purpose of this manual, a chimney chase is considered a part of the chimney system rather than part of a building. The termination must be placed a minimum of 18" (460 mm) above the chase.

For installations where more than one chimney is located in the same chase or within the same area, we suggest that their terminations be separated by at least 16" (410 mm) horizontally, and 18" (460 mm) vertically. This separation is to prevent smoke migrating from one chimney to another (see figure 44).

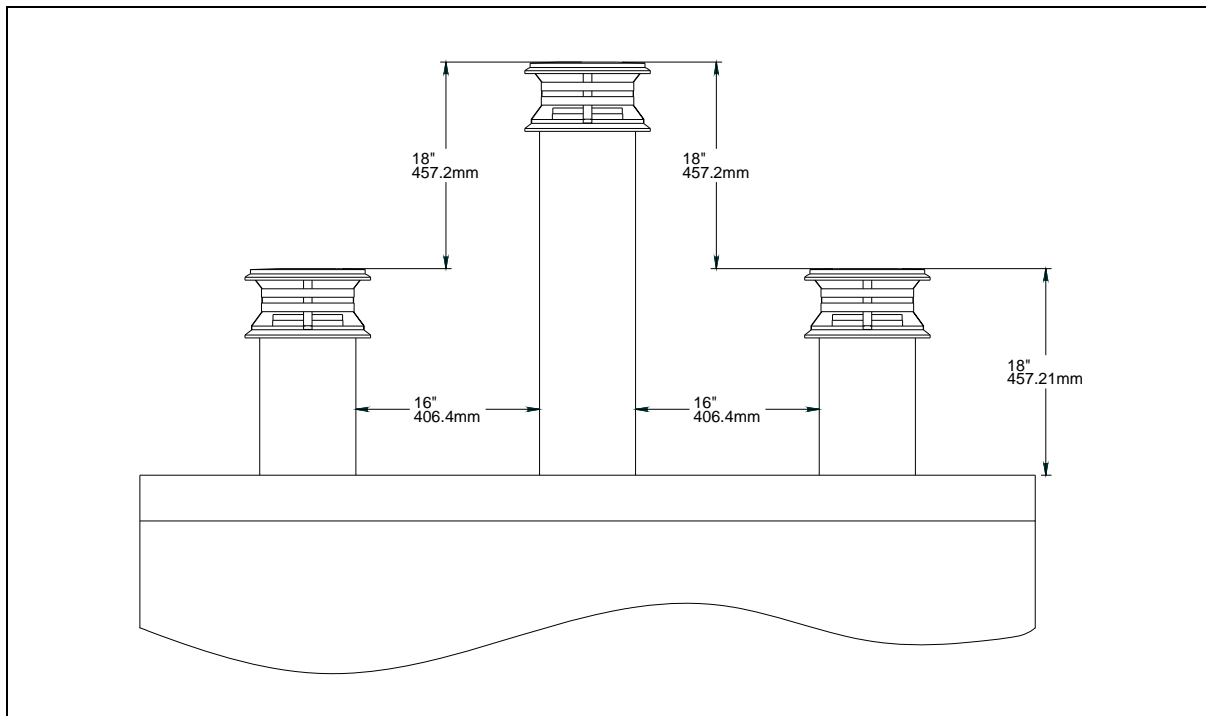

Figure 44

3.7 INSTALLATION INSTRUCTIONS FOR MASONRY APPLICATION

WARNING: Before starting the installation, the masonry chimney must be inspected by a qualified sweep.

The following requirements must be respected:

1. The chimney must be absolutely clear of any soot residue or creosote. Check for cracks, loose or missing bricks that could inhibit correct installation of the liner.
2. The clearance to combustible must be a minimum of 1" between the outside of the masonry and any wood framing or loose insulation.
3. The chimney must be built in accordance with the current building code.
4. No other appliance can be connected to the same chimney.

Installation:

The chimney must be relined with a stainless steel liner of the same diameter as the outlet of the fireplace. For connection at 30° or 45° angle, a special connector must be used to connect the liner to the insulated chimney. Verify availability and installation instructions for this connector with the chimney manufacturer.

Follow these steps:

1. Position the fireplace in its location. Temporarily install the elbow on the top of the fireplace and, using a level, mark with an oval the location where the flue liner will enter the masonry chimney.
2. In the middle of the oval, drill a hole in the masonry chimney at 45° or 30°.
3. Increase the size of the hole until a 45° or 30° liner elbow can be easily slipped through.
4. Slide the liner down from the top of the masonry chimney until you reach the hole level.
5. Slip through the hole a 45° or 30° liner elbow and connect it to the liner.
6. Add a small liner section to the liner elbow which will allow the liner to extend at least 12" (measured at the top of the liner) from the masonry chimney.
7. Seal the opening around the liner with high temperature refractory cement.
8. Then, follow the chimney manufacturer's instructions to connect the extended liner section to the special chimney connector.

See typical installation illustrated below.

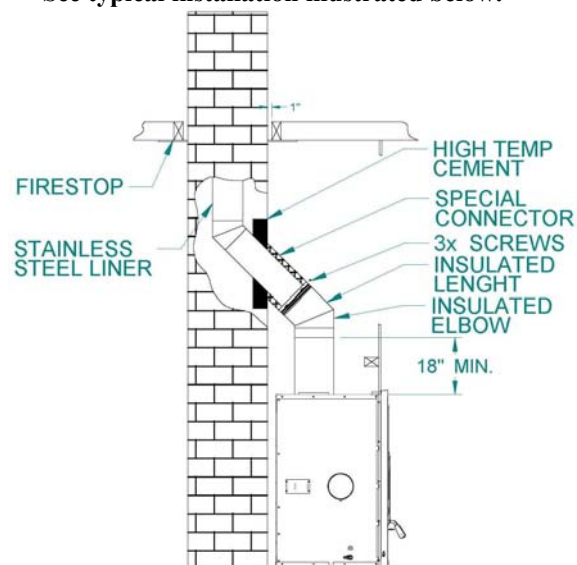

Figure 45

4. OPTIONS

Gravity kit:

Includes: one deflector, two 90° elbows, and two outlet grilles and frames,

Part No.:

#AC01309

Central forced air kit:

Includes: one blower, one 5" flex adapter, 3 pipe clamps, and one control box with heat sensor and PC Board.

#AC01340

Outside air kit

Includes: one 3" flex adapter, 2 pipe clamps, and one outside wall register

#AC03500

Rigid fireguard

Includes: one rigid fireguard

#AC01308

Rafter protector

Includes: one rafter protector kit*

#AC03510

**May be required if the chimney manufacturer does not supply rafter protectors.*

Each rafter is made of 22GA galvanized steel (10.44" W x 5.376" H).

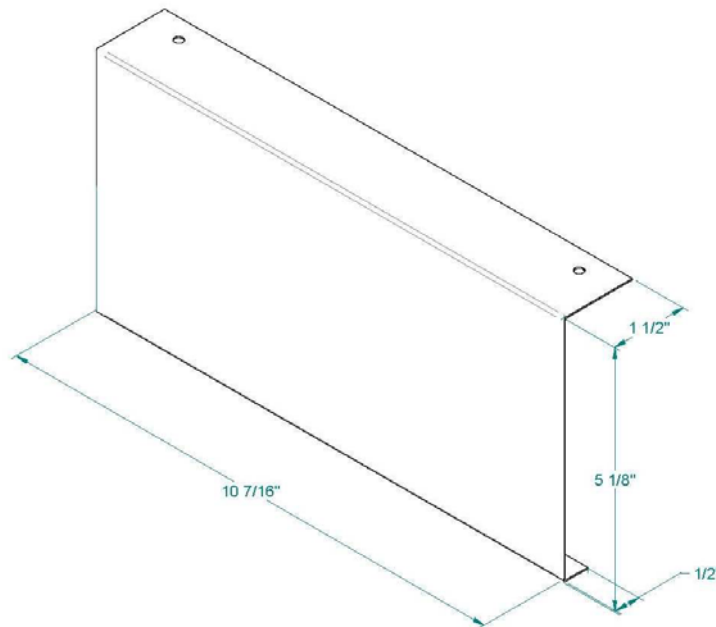

Figure 46

5. APPENDIX

5.1 SPECIFICATIONS

Weight: 385 lbs

Height: 43 1/4"

Width: 36 3/4"

Depth: 26"

Maximum recommended heating area: 500 to 2,100 square feet (with forced air kit)

Heating capacity* – BTU/hr., EPA test wood: 30,500

Heating capacity* – BTU/hr., seasoned cordwood: 75,000

Optimum efficiency: 77%

**Why is the BTU indicated on the EPA label smaller than the one advertised?*

You will notice a difference between the BTU output as indicated on the unit's white EPA label affixed to the glass and the BTU as advertised on our web site and/or product literature. The maximum BTU output we advertise for this unit is what will be obtained with a full load of seasoned cordwood inserted inside the firebox. The EPA output, on the other hand, is what has been obtained during emissions testing. The EPA test procedure requires that a special type of wood be used and positioned inside the firebox in a manner that does not represent the way the firebox volume would normally be utilized using seasoned cordwood. The EPA test load is typically much smaller. Hence, the BTU as per the EPA label is reduced. The BTU output that should be considered by a normal user is the one we advertise for seasoned cordwood.

5.2 CLEARANCE TO COMBUSTIBLES

The following clearances meet the minimum requirements for a safe installation

Side wall: 17" (43 cm) measured from the outside door frame.

Side mantle: 0" (must have a depth no greater than 3").

In front of fireplace: 48"

Ceiling: 7 ft. (2.15 m) measured from the base of the fireplace.

Fireplace enclosure: Bottom: 0"

Side: 0"

Back: 0"

Top: Do not fill the space above the fireplace with any material (except the wood framing).

Chimney: 2" (50 mm)

Combustible shelf: See Section 2.4.3, Figure 17

5.4 THERMAL CHARACTERISTICS OF COMMON FLOOR PROTECTION MATERIALS*

MATERIAL	CONDUCTIVITY (k) PER INCH	RESISTANCE (R) PER INCH THICKNESS
Micore® 160	0.39	2.54
Micore® 300	0.49	2.06
Durock®	1.92	0.52
Hardibacker®	1.95	0.51
Hardibacker® 500	2.3	0.44
Wonderboard®	3.23	0.31
Cement mortar	5.00	0.2
Common brick	5.00	0.2
Face brick	9.00	0.11
Marble	14.3 – 20.00	0.07 – 0.05
Ceramic tile	12.5	0.008
Concrete	1.050	0.950
Mineral wool insulation	0.320	3.120
Limestone	6.5	0.153
Ceramic board (Fibremax)	0.450	2.2
Horizontal still air** (1/8")	0.135	0,920**

* Information as reported by manufacturers and other resources

** For a 1/8" thickness. You cannot «stack» horizontal still air to accumulate R-values; you must separate each later of horizontal still air with another noncombustible material.

Exploded view for replacement parts

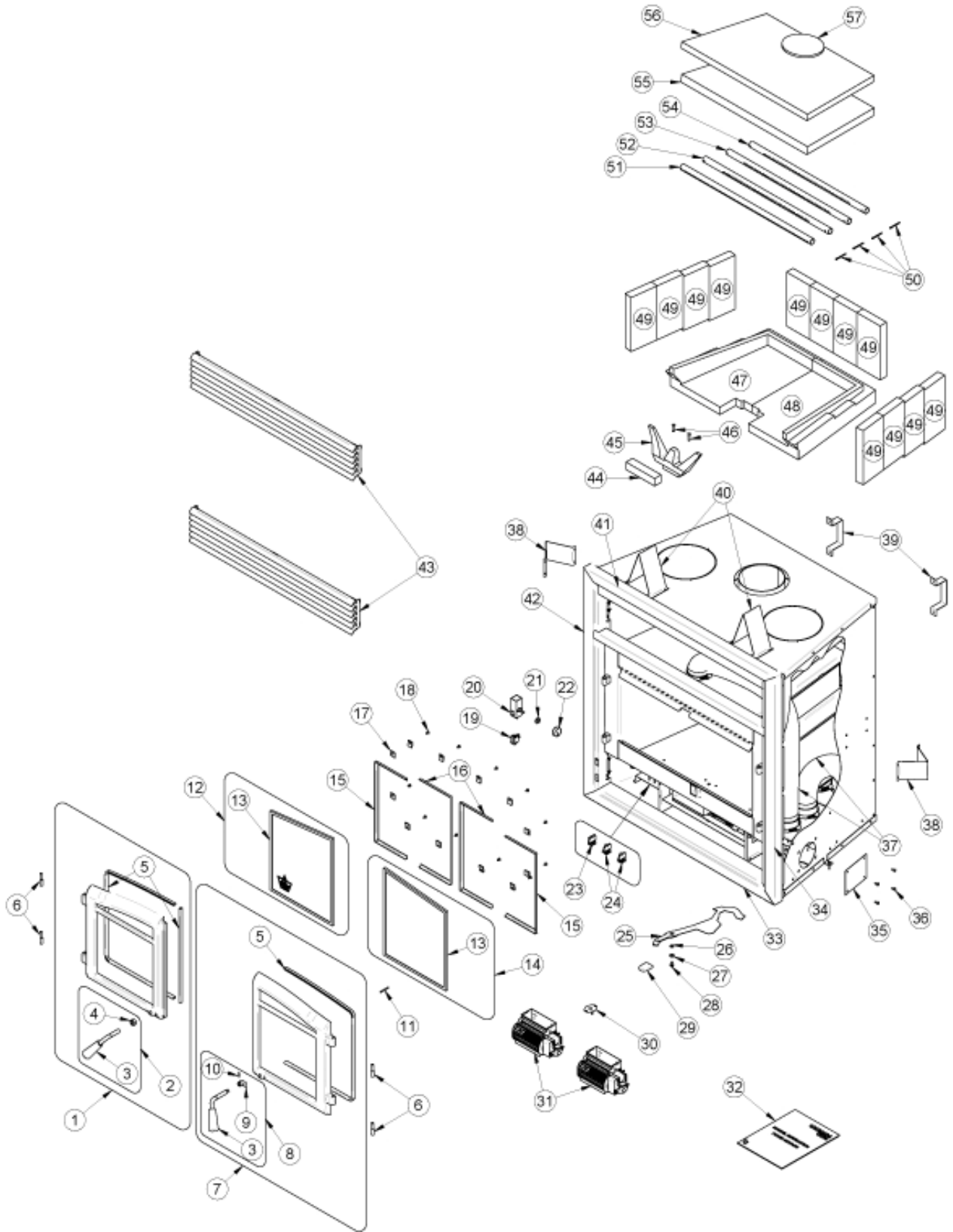

List of replacement parts

1	SE24154	LEFT DOOR WITH HANDLE AND GASKET	1
2	AC09193	LH SIDE BENT HANDLE REPLACEMENT KIT	1
3	30569	BLACK ROUND WOODEN HANDLE	2
4	30039	NUT 1/2-20	1
5	AC06200	BLACK GASKET AND SILICONE KIT 1/4" X 1/2" X11'	2
6	30579	ADJUSTABLE HINGE PIN 3/8" - 5/16" DIA X 1 63/63" LONG	4
7	SE24155	RIGHT DOOR WITH HANDLE AND GASKET	1
8	AC09192	RH SIDE BENT HANDLE AND LATCH REPLACEMENT KIT	1
9	24153	FIREPLACE DOOR LATCH	1
10	30114	SPRING PIN 5/32" DIA X 5/8" LONG	1
11	30101	SPRING TENSION PIN 5/32" DIA X 1 1/2" LONG	1
12	SE53075	LEFT REMPLACEMENT GLASS WITH GASKET 12" X 13 3/16" X 14 1/2"	1
13	AC06400	BLACK SELF-ADHESIVE GLASS GASKET KIT (6')	2
14	SE53074	RIGHT REMPLACEMENT GLASS WITH GASKET 12" X 13 3/16" X 14 1/2"	1
15	PL53097	OUTER GLASS RETAINER FRAME	2
16	PL53098	INNER GLASS RETAINER FRAME	2
17	PL53585	GLASS RETAINER	12
18	30124	SCREW #8 - 32 X 5/16" TRUSS QUADREX ZINC	12
19	44091	ROCKER SWITCH 2 POSITION MSR-8	1
20	44084	RHEOSTAT WITH NUT	1
21	44087	RHEOSTAT NUT	1
22	44085	RHEOSTAT KNOB	1
23	60204B	TERMINAL BLOCK (END SECTION)	1
24	60204A	TERMINAL 3/8" SECTION	2
25	PL63866	AIR CONTROL MECHANISM	1
26	30187	ZINC WASHER ID 17/64" x OD 1/2"	1
27	30185	17/64" "AA" TYPE WASHER	1
28	30060	THREAD-CUTTING SCREW 1/4-20 x 1/2" F HEX STEEL SLOT WASHER C102 ZINC	1
29	30556	AIR CONTROL FINISHING TIP	1
30	44046	THERMODISC F110-20F	1
31	44073	CROSSFLOW BLOWER 115V-60Hz-39W 100 CFM (P)	2
32	SE45182	FLAME Z.C. INSTRUCTION MANUAL	1
33	PL53154	BOTTOM OF FACEPLATE	1
34	PL53153	RH SIDE OF FACEPLATE	1
35	PL53026	AIR INTAKE BOX COVER	1
36	30154	BLACK SCREW #10 X 5/8" ROBERTSON TYPE A	4
37	21076	2 PLY ALUMINUM LINER 3.149" X 36" (COMPRESSED AT 27 1/2")	2
38	PL53066	SIDE SPACER	2
39	PL53065	REAR SPACER	2
40	PL53064	UPPER SPACER	2
41	PL53139	FACEPLATE TOP	1
42	PL53152	LH SIDE OF FACEPLATE	1
43	OA10604	BLACK TRIM KIT	2
43	OA10605	GOLD PLATED TRIM KIT	2
43	OA10606	NICKEL TRIM KIT	2
44	21147	FRONT FLOOR REFRACTORY 5 1/2" X 1 1/4" X 1 1/4"	1
45	PL53144	LOG HOLDER	1
46	30506	SCREW PAN TORX TYPE F 1/4-20 X 1" BLACK	2
47	22122	LEFT FLOOR REFRACTORY SLAB	1
48	22123	RIGHT FLOOR REFRACTORY SLAB	1
49	29020	4 1/2" X 9" X 1 1/4" REFRACTORY BRICK HD	12
50	30068	STAINLESS STEEL COTTER PIN 1/8" X 1 1/2"	4
51	PL53132	FRONT SECONDARY AIR TUBE	1
52	PL53133	FRONT CENTER SECONDARY AIR TUBE	1
53	PL53134	REAR CENTER SECONDARY AIR TUBE	1
54	PL53135	REAR SECONDARY AIR TUBE	1
55	21134	VERMICULITE BAFFLE 24 3/16" X 14 25/32" X 1 1/4"	1
56	21148	BAFFLE INSULATION 24 3/16" x 20 5/8" x 14 3/4" x 1"	1
57	PL34026	BAFFLE INSULATION WEIGHT	1

6. FLAME LIMITED LIFETIME WARRANTY

The warranty of the manufacturer extends only to the original consumer purchaser and is not transferable. This warranty covers brand new products only, which have not been altered, modified nor repaired since shipment from factory. Products covered under this warranty must have been manufactured after the revision date indicated below. Proof of purchase (dated bill of sale), model name and serial number must be supplied when making any warranty claim to your FLAME dealer.

This warranty applies to normal residential use only. Damages caused by misuse, abuse, improper installation, lack of maintenance, over firing, negligence or accident during transportation, power failures, downdrafts, or venting problems are not covered by this warranty.

This warranty does not cover any scratch, corrosion, distortion, or discoloration. Any defect or damage caused by the use of unauthorized parts or others than original parts void this warranty. An authorized qualified technician must perform the installation in accordance with the instructions supplied with this product and all local and national building codes. Any service call related to an improper installation is not covered by this warranty.

The manufacturer may require that defective products be returned or that digital pictures be provided to support the claim. Returned products are to be shipped prepaid to the manufacturer for investigation. If a product is found to be defective, the manufacturer will repair or replace such defect. Transportation fees to ship the product back to the purchaser will be paid by the manufacturer. Repair work covered by the warranty, executed at the purchaser's domicile by an authorized qualified technician requires the prior approval of the manufacturer. Labour cost and repair work to the account of the manufacturer are based on predetermined rate schedule and must not exceed the wholesale price of the replacement part. All parts and labour costs covered by this warranty are limited according to the table below.

The manufacturer at its discretion may decide to repair or replace any part or unit after inspection and investigation of the defect. The manufacturer may, at its discretion, fully discharge all obligations with respect to this warranty by refunding the wholesale price of any warranted but defective parts. The manufacturer shall in no event be responsible for any special, indirect, consequential damages of any nature, which are in excess of the original purchase price of the product. A one-time replacement limit applies to all parts benefiting from a lifetime coverage. This warranty applies to products purchased after October 1st, 2011.

DESCRIPTION	WARRANTY APPLICATION	
	PARTS	LABOUR
Combustion chamber (welds only), castings, convector air-mate, ceramic glass (thermal breakage only*), and secondary air tubes*.	Lifetime	4 years
Plating* (defective manufacture) – subject to limitations above.	Lifetime	n/a
Stainless steel firebox components, surrounds and heat shields, ash drawer, steel legs, pedestal, trims (aluminum extrusions), C-Cast baffle*, and vermiculite baffle*.	5 years	3 years
Carbon steel firebox components, glass retainers, and handle assembly.	3 years	2 years
Blowers, heat sensors, switches, rheostat, wiring, and other controls.	2 years	1 year
Paint (peeling), gaskets, insulation, firebrick, and ceramic fibre blankets.	1 year	n/a

**Pictures required*

Shall your unit or a components be defective, contact immediately your **FLAME** dealer. Prior to your call make sure you have the following information necessary to your warranty claim treatment:

- Your name, address and telephone number;
- Bill of sale and dealer's name;
- Serial number and model name as indicated on the nameplate fixed to the back of your unit;
- Nature of the defect and any relevant information.

Before shipping your unit or defective component to our plant, you must obtain from your FLAME dealer an Authorization Number. Any merchandise shipped to our plant without authorization will be refused automatically and returned to sender.