



Mojave
Sun **IR**™

Infrared Heating System

Owner's Manual

Model #:MS-1500WOIRPH

READ & SAVE These Instructions

Carefully read and review before attempting to assemble, install, operate or maintain this product. Observe all safety instructions and information. **FAILURE TO FOLLOW WARNINGS & OPERATIONAL INSTRUCTIONS CONTAINED IN THIS MANUAL CAN RESULT IN SEVERE PROPERTY DAMAGE AND/OR PERSONAL INJURY.**

**** For Residential Use Only ****

***** Important Notice *****

Do not return to place of purchase!

Please contact our Toll Free Hotline:
(866) 985-7877
for customer service & warranty issues

SAVE THESE INSTRUCTIONS !!



Another lifestyle enhancing product from...

Web: www.wtliving.com
Email: cservice@welltraveled.net



Well Traveled Living
Amelia Island, FL 32034

***** Important Notice *****

Do not return to place of purchase!!

Please contact our Toll Free Hotline:
(866) 985-7877
for customer service & warranty issues



Safety Guidelines

Read this manual carefully for guidance on the assembly and use of this product.

DANGER

Indicates a potentially hazardous situation which, if not avoided, WILL result in serious injury or death.

WARNING

Indicates a potentially hazardous situation, if not avoided, COULD result in serious injury or death.

CAUTION

Indicates a potentially hazardous situation which, if not avoided, MAY cause moderate injury or damage to the equipment.

NOTICE:

Indicated important information that if not followed, may cause damage to the equipment.

DANGER

1



Risk of Fire. There is always a risk of fire when working with a heater. Keep heater away from flammable liquids and materials.



2. **Risk of Fire.** If falls over this unit might start a fire. Follow instructions above and also for further prevention keep this unit at least 3 feet (.9m) away from everything.



3. **Hot or Burn Hazard.** This unit may be extremely hot while in use. Careful when handling especially around the head of the unit.



4. **Electrical Hazard.** Disconnect from electrical outlet before working on the unit to avoid chance of electrical shock.



5. **Electric Shock.** Do not use near water. Do not use if cord has been damaged.

CAUTION

- Improper treatment of the heater can damage it and also shorten its life span.
- To prevent electrical shock, ensure electrical plug is properly inserted into the electrical outlet.

***** Important Notice *****

Do not return to place of purchase!!

Please contact our Toll Free Hotline:

(866) 985-7877

for customer service & warranty issues



Product Components & Parts List

This appliance MUST be grounded.

- * When using outdoors, we recommend using a certified GFI (Ground Fault Interrupt) outlet to protect against electrical shock.
- * All installations must be in accordance with I.E.E. safety regulations or equivalent.
- * Avoid the use of an extension cord with this appliance.
- * Do not place any objects such as furniture, papers, clothing or curtains closer than 3 ft to the front and sides of the heater.



PARTS LIST

- 1 - IR Head Unit w/ Protective Shield
 - Pre-installed safety shut off, tilt switch
 - Preassembled aluminum main heating unit w/1500W quartz halogen lamp, swivel bracket & 12 ft., 16/3 grounded electrical cord.
- 2 - Mounting Bracket - Head unit to telescopic stand
- 3 - Curved Upper Arm - tubular stainless steel
- 4 - Inner support tube section for telescopic body
- 5 - Telescopic Body - Stainless steel, adjustable, 2 sections with 2 easy release clamp collars.
- 6 - Support Collar/Flange for Telescopic Body - Stainless steel
- 7 - Base Assembly w/ Wheels
- 8 - Hardware - 20 threaded bolts/screws, phillips pan head.

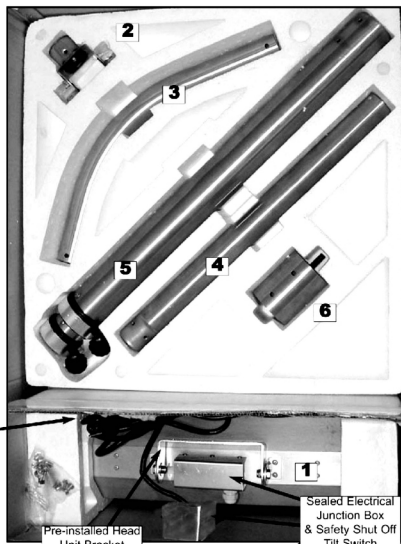

Base & Wheel assembly with support collar/flange



Pre-installed, 16/3 grounded electrical cord

Pre-installed Head Unit Bracket

Sealed Electrical Junction Box & Safety Shut Off Tilt Switch

Head Unit Assembly



Pre-installed aluminum shield

***** Important Notice *****

Do not return to place of purchase!

Please contact our Toll Free Hotline:

(866) 985-7877

for customer service & warranty issues



Important Instructions

1. Read all instructions before using this heater.
2. This heater will get very hot while in use. To avoid burning, do not let bare skin touch hot surfaces. If provided, use handles when moving this heater. Keep flammable materials, such as furniture, pillows, bedding, papers, cloths, and curtains at least 3 feet (0.9m) from the heater.
3. **DO NOT LEAVE** heater unattended. Extreme caution is necessary when any heater is used by, or near, children or disabled persons, and whenever the heater is left operating and unattended
4. Always unplug heater when not in use.
5. Do not operate any heater with a damaged cord or plug, if the heater malfunctions, or has been dropped or damaged in any manner. Return heater to authorized service facility for repairs.
6. Can be used indoors or outdoors, operate 3 feet (0.9m) from people or objects.
7. Never operate heater near water or where it can be knocked over.
8. Do not run cord under carpeting. Do not cover cord with throw rugs, runners, or similar coverings. Arrange cord away from traffic area and where it will not be tripped over.
9. To disconnect heater, remove plug from electrical outlet.
10. Connect to properly grounded outlets only.
11. Do not insert or allow foreign objects to enter ventilation or exhaust opening; doing so may cause an electrical shock or fire, or may damage the heater.
12. To prevent a possible fire, do not block air intakes or exhaust in any manner. Do not use on soft surfaces, like a bed, where openings may become blocked.
13. A heater has hot and sparking parts inside. Do not use it in areas where gasoline, paint, or flammable liquids are used or stored.
14. Use this heater only as described in this manual. Any other use not recommended by the manufacturer may cause fire, electrical shock, or injury to persons.
15. Avoid the use of an extension cord because the extension cord may overheat and cause a risk of fire. However, if you have to use an extension cord, use either a 12 or 14 gauge wire which is rated not less than 1900 watts. The recommended length for a 14 gauge is 0-50 feet, but if need be long use a 12 gauge no longer than 100 feet.
16. **SAVE THESE INSTRUCTIONS** for future reference.

***** Important Notice *****

Do not return to place of purchase!!

Please contact our Toll Free Hotline:
(866) 985-7877
for customer service & warranty issues

**Assembly
Instructions**



Step 1

Be sure to read and familiarize yourself with the overall assembly process and instructions in this manual before beginning. It may be helpful to have someone assist you with the assembly.

Tools Required: #2 or #3 Phillips Screwdriver (or standard slotted screwdriver), and Adjustable Wrench

Find a clean, level, preferably carpeted location to assemble your IR Heater. A flat piece of cardboard will work as well. Unpack and identify all components listed on page 3 of this manual and lay them out on the carpeted floor or cardboard piece.

Step 2

Attach mounting bracket for head unit to curved upper arm using 4 threaded bolts. The bracket base will fit inside the upper arm. Securely tighten all bolts.

Note: See Fig. 1 for proper orientation of bracket to upper arm.
The bracket will only align properly to one correct end of the arm.

Beginning at the mounting bracket end, thread the entire electrical cord from the IR head unit & tilt switch component thru the curved upper arm. Attach head unit bracket to the mounting bracket using 4 threaded bolts. Apply all bolts loosely for easier alignment & positioning. Now attach tilt switch box to mounting bracket using 2 bolts. Check to make sure all components fit together properly, then tighten all bolts securely.

NOTE: Junction box and electrical cord coming out of the head unit & tilt switch MUST be facing downward when installed. See Fig. 2 for proper position.

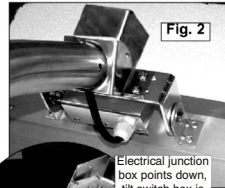
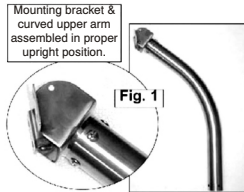

Step 3

Attach support collar/flange to base. Thread collar thru hole in base and Hand tighten securely. See Fig. 2A.

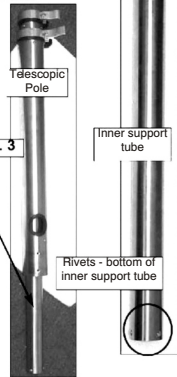
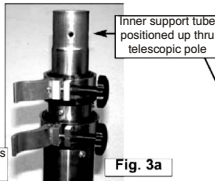

Step 4

Slide inner support tube (end with rivets must be towards bottom) thru bottom of telescopic pole & up thru the top. Pull out upper release lever and loosen clamp knob to allow tube to pass thru the top section. See Fig. 3

Pull out second release lever and loosen clamp knob and slide both sections to their lowest position (about 1" from the top of each respective clamp collars). Do not allow sections to fall below below the clamp collar. Tighten both clamp knobs and push in clamp levers to secure both sections. See Fig. 3a

Step 5

Carefully lift and position the telescopic body into the installed support collar/flange of the cast iron base. See Fig. 4. Align the holes and attach using 6 threaded bolts. Apply all 6 bolts loosely for easier alignment and positioning. Then tighten all bolts securely.

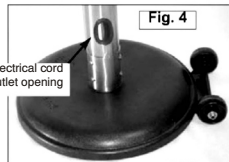

***** Important Notice *****

Do not return to place of purchase!!

Please contact our Toll Free Hotline:
(866) 985-7877

for customer service & warranty issues

**Assembly
Instructions**



Step 6

Carefully lift the completed head unit assembly from step 2 over the telescopic body and completely route the electrical cord down thru the top of the body and pull the end thru the large outlet opening at the base of the body. **See Fig. 5.**

Position the completed head unit assembly onto the upright telescopic body assembly. **See Fig.6.** The bottom end of upper curved arm from the assembly will fit over the smaller top tube of the telescopic body. Attach the head unit assembly & arm to the telescopic pole using 1 threaded bolt, tighten securely. Pull all slack from the electrical cord at the base of the telescopic body.

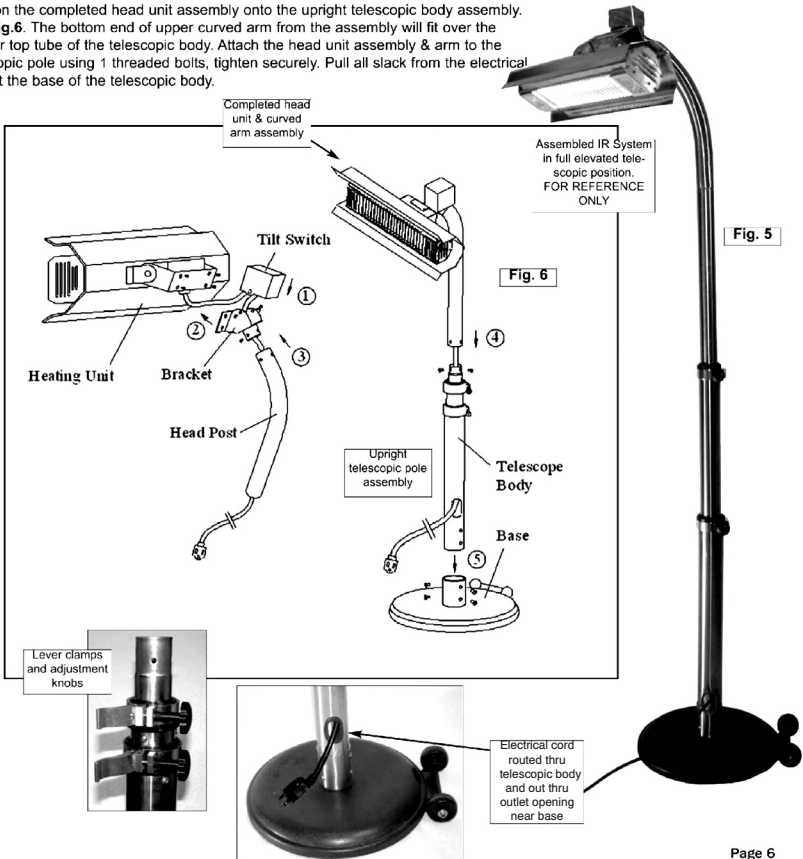

***** Important Notice *****

Do not return to place of purchase!!

Please contact our Toll Free Hotline:

(866) 985-7877

for customer service & warranty issues

Operating Instructions



This appliance MUST be grounded.

- * When using outdoors, we recommend using a certified GFI (Ground Fault Interrupt) outlet to protect against electrical shock.
- * All Installations must be in accordance with I.E.E. safety regulations or equivalent.
- * Avoid the use of an extension cord with this appliance. If one is used, it **MUST** be at least a **14/3 wire, grounded cord, 50ft max. length.**
- * Do not place any objects such as furniture, papers, clothing or curtains closer than 3 ft to the front and sides of the heater.
- * **ALWAYS** unplug the IR Heater unit when not in use.



*For optimal performance and safety concerns, we **HIGHLY RECOMMEND** that the Infrared Heating System be operated at a min. of 98" ht. or the maximum extended length of the telescopic body sections.*

To Adjust The IR Telescopic Body:

Pull up on release levers of tightening clamps and adjust tension using the black knobs. Raise and lower the telescopic sections and/or swivel to desired position and then push in clamp levers to secure. Do NOT over tighten tension knobs. There should only be a moderate amount of tension to maintain the telescopic position of your heater.

Note: Be sure to adjust the slack as needed on the electrical cord when raising or lowering telescopic body.



Lever clamps and adjustment knobs

Step 1

Before turning on your Infrared Heating System, extend all 3 telescopic sections to their maximum extended length. Release clamp levers and pull up on each of the sectional steel tubes until each tube stops. Then push in clamp levers to secure sections in place. Adjust the tension knobs as needed to maintain height position.

Refer to coverage area in Fig. 7 for best positioning location.

Place the infrared heater on FLAT, LEVEL surface only.

Move and position the electrical cord so it is not a trip hazard and not exposed to water or moisture.

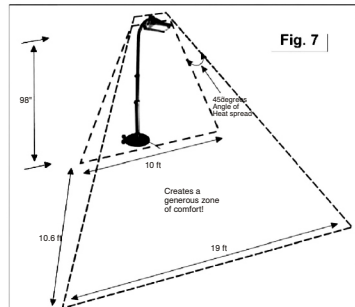

Step 2

The infrared electric heating system comes equipped with a heavy duty, 16/3 gauge wire and grounded plug. This appliance must be used with an outlet that has been installed and grounded in accordance with all local codes and ordinances. Make sure that the heater is connected to an outlet having the same configuration as the plug shown in Fig. 8. Do NOT use an adapter with this product. Check with a licensed electrician if the grounding instructions are not understood completely or if the wall outlet does not match the plug.

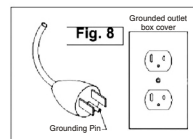

Step 3

Always UNPLUG unit when not in use!

Your Mojave Sun, infrared electric heating system is ready to enjoy. Plug the appliance in and beginning enjoying the warmth!

Safety Tilt Switch Mechanism: This unit has a built in shut off system. Power will shut off automatically should the unit be accidentally knocked over or tilted past 15 degrees. To reset, unplug unit from wall outlet, reposition on a flat level surface and plug in again.



***** Important Notice *****

Do not return to place of purchase!

Please contact our Toll Free Hotline:

(866) 985-7877

for customer service & warranty issues

Maintenance & Storage



Specifications

Model:	MS-1500WOIRPH
Voltage:	120 volts
Amps:	12.5 amps
Wattage:	1500 watts
Lamp Type:	Quartz Halogen
Min. Operational Height:	8ft. 2" (98")
Weight:	53 lbs.
Head Unit Dimensions:	4.5" x 7" x 22"
Complete Assembled Dimensions:	18" base, 98" ht.

Storage

Always UNPLUG unit when not in use!

- * **Always cover** the head unit with the outdoor vinyl cover included with your heater when not in use. Be sure to allow the heater to cool down before covering.
- * When not in use for extended periods of time, store under a covered location that is dry, out of the weather, safe and out of the way of people & pets that might accidentally knock over or damage the appliance.
 - Make sure the electrical cord is coiled and out of the way.
- * **When storing, ALWAYS reduce the telescopic pole to it's lowest level.** This will make it easier to store and reduce the risk of an accidental knock over.

Note: It is not necessary to remove any of the components or parts when storing this unit.



Maintenance

Your infrared heating system is virtually maintenance free! A few minutes to wipe down exposed surfaces is all it takes.

- * **Head Unit & Aluminum Shield** - Use any non-abrasive cleaner and soft cloth to wipe off debris and dirt from the exposed surfaces of the aluminum shield and outer body of the head unit and outer grill. NEVER spray any liquids or cleaners into the housing area where the halogen lamp is located. Do not try to disassemble or clean the inner cavity where the halogen lamp is located.

Note: For any maintenance on the head unit, please call the toll free customer service hotline

- * **Telescopic Pole & Curved Arm Components** - These are all made from stainless steel materials and can easily be wiped clean using any non-abrasive cleaners and a soft cloth.
- * **Base w/Wheel Assembly** - Use non-abrasive cleaners and a soft cloth. Any scratches, chips or rust spots can be touched up using an exterior matte finish, black paint.

***** Important Notice *****

Do not return to place of purchase!!

Please contact our Toll Free Hotline:

(866) 985-7877

for customer service & warranty issues

Halogen Lamp Replacement



Contact toll free customer service hotline to order approved replacement lamps and parts.

NOTE: do NOT touch the new halogen lamp with your bare fingers. Oils from your hand could reduce the life of the lamp by causing a heat spot. Recommend using clean cotton or plastic gloves. A clean paper towel may also work.



Make sure heater is DISCONNECTED from electrical outlet BEFORE beginning

Quartz Halogen Lamp Replacement:

- * Be sure unit is unplugged from wall outlet!
- * Remove head unit assembly from telescopic pole stand (refer to step 6 for reference)
- * Remove 8 screws from each end of the head unit and pull off end plates (see #2)
 - Note the placement of the 2 small sheet metal screws on each end plate. Also, note end plate side with beveled holes faces outward when re-assembled.
- * Pull out & remove the left & right, front air vent panels and protective wire grill. (see #3)
 - Note position of end clips on vent panel. They must be aligned as close to end connectors of lamp tube as possible when re-assembled. Pull out and/or pushed into place. **Do NOT allow any metal parts to touch the actual lamp tube when re-assembled.**
- * Gently pull out entire old lamp assembly from the clips at the terminal connection ends. (see #4 & #5). Slide and lift the connection ends out from the friction clips by gently pushing apart the clips. Unscrew wire leads from terminal. Remove entire old lamp assembly.
- * Using gloves, gently re-insert connection ends of the NEW lamp assembly into the friction clips (see #4). Pull apart the clips slightly and gently push the connectors into place. Do not allow the metal clips to touch the actual lamp tube. The clips should be about at the center point of the end connectors.
- * Re-install safety grill (fits along grooves in housing body). Then, re-insert vent panels by gently pushing the end clips into housing body, align clip ends close to lamp end connectors and push into place. Now re-attach end plates, make sure side with beveled holes faces out.



Use ONLY approved, original equipment replacement quartz halogen lamps to insure safe, proper and maximum output operation of your infrared heater!

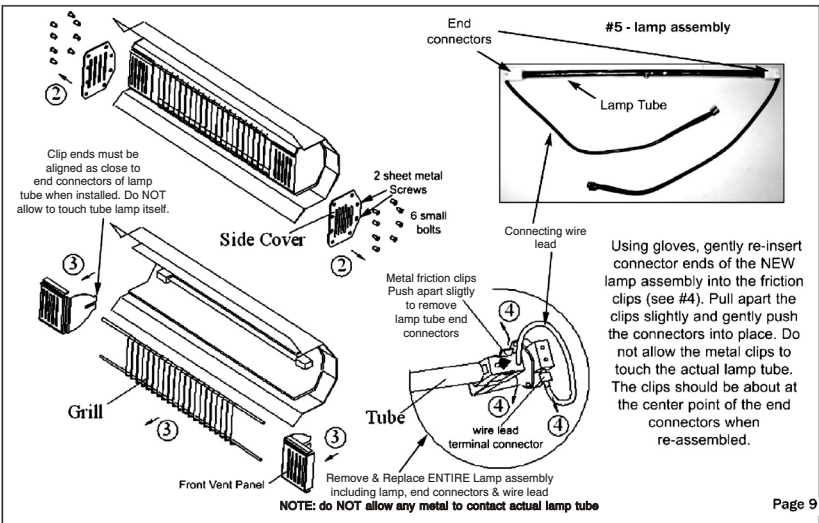

Using gloves, gently re-insert connector ends of the NEW lamp assembly into the friction clips (see #4). Pull apart the clips slightly and gently push the connectors into place. Do not allow the metal clips to touch the actual lamp tube. The clips should be about at the center point of the end connectors when re-assembled.

Trouble Shooting

Problem	Solution
Unit fails to turn on.	Check electrical plug connection at wall outlet for complete, snug fit. Check GFI circuit, reset breaker if necessary Possibly connected to wall switch that is in off position Damaged halogen lamp, call customer service hotline
Telescopic pole slips down Telescopic pole is unsteady Telescopic pole will NOT adjust up or down	Reset safety "tilt switch" shut off mechanism. Unplug unit from wall outlet, re-position unit on level surface and plug in again. Tighten black tension knobs on clamp collars. Tighten screws on support collar at support base. Electrical cord may be bunched. Gently pull end of cord taught to remove any kinks or bunching.
Head unit is loose or unsteady Head unit is hard to adjust	Tighten screws on curved upper arm mounting bracket Loosen connecting bolts/nuts at adjustment bracket
Smoke appears from head unit	Unplug IMMEDIATELY & call customer service hotline
Weak light output from halogen lamp	Life span of lamp has been reached or damaged lamp Call customer service hotline for assistance.

Distributed By:
Well Traveled Living
716 S 8th Street
Amelia Island, FL 32034
Toll Free: 866-WTL-SUPP



Web: www.welltraveled.com
Email: cservice@welltraveled.net

1 YEAR LIMITED WARRANTY – Customers In the Continental US

All components are warranted for a period of 1 year after date of purchase by the original owner against defects in materials and workmanship under normal use. This warranty does NOT cover normal wear and weathering, assembly and/or maintenance OR use in a commercial application. At Well Traveled Living's sole discretion, products under warranty will be repaired and/or replaced at no charge to the customer. Any returns sent back to Well Traveled Living must be sent via prepaid freight and in the original retail packaging.

For warranty service contact Well Traveled Living at the address, phone numbers or internet site and email listed in this owner's manual. Be sure to have your sales receipt, date of purchase, and catalogue/model numbers available when calling. All warranty service will be coordinated by the Well Traveled Living's Amelia Island, Florida service center.

This warranty is extended only to the original purchaser. Proof of purchase will be required before warranty service is rendered. The sales receipt is the only valid proof of purchase. This warranty only covers failures due to defects in materials or workmanship which occur during normal use. Failures and/or damage which result from accident, negligence, misuse, abuse, neglect, mishandling, alteration or modification, failure to maintain, improper assembly or maintenance, service by unauthorized agency or use of unauthorized components or damage that is attributable to acts of God are NOT covered.

THERE ARE NO EXPRESS WARRANTIES EXCEPT AS LISTED ABOVE

PURCHASER ASSUMES ALL RISKS IN THE ASSEMBLY AND OPERATION OF THIS UNIT

FAILURE TO FOLLOW WARNINGS AND OPERATIONAL INSTRUCTIONS CONTAINED IN THIS MANUAL CAN RESULT IN SEVERE PROPERTY DAMAGE AND/OR PERSONAL INJURY

IN NO EVENT WILL WELL TRAVELED LIVING, OR ITS DIRECTORS, OFFICERS OR AGENTS BE LIABLE TO THE PURCHASER OR ANY THIRD PARTY, WHETHER IN CONTRACT, IN TORT, OR ON ANY OTHER BASIS, FOR ANY INDIRECT, SPECIAL, PUNITIVE, EXEMPLARY, CONSEQUENTIAL, OR INCIDENTAL LOSS, COST, OR DAMAGE ARISING OUT OF OR IN CONNECTION WITH THE SALE, MAINTENANCE, USE, OR INABILITY TO USE THE PRODUCT, EVEN IF WELL TRAVELED LIVING OR ITS DIRECTORS, OFFICERS OR AGENTS HAVE BEEN ADVISED OF THE POSSIBILITY OF SUCH LOSSES, COSTS OR DAMAGES, OR IF SUCH LOSSES, COSTS, OR DAMAGES ARE FORESEEABLE. IN NO EVENT WILL WELL TRAVELED LIVING, OR ITS OFFICERS, DIRECTORS, OR AGENTS BE LIABLE FOR ANY DIRECT LOSSES, COSTS OR DAMAGES THAT EXCEED THE PURCHASE PRICE OF THE PRODUCT.

SOME JURISDICTIONS DO NOT ALLOW THE EXCLUSION OR LIMITATION OF INCIDENTAL OR CONSEQUENTIAL DAMAGES, SO THE ABOVE LIMITATION OR EXCLUSION MAY NOT APPLY TO THE PURCHASER.

This limited warranty gives you specific legal rights and you may also have other rights which vary from jurisdiction to jurisdiction. The provisions of the United Nations Convention on Contracts for the Sales of Goods shall not apply to this limited warranty or the sale of products covered by this limited warranty.

IMPORTANT NOTICE

-Do NOT return to place of purchase-
For customer service and warranty issues
contact our Customer Service Center at:
(866)-985-7877 OR
Email: cservice@welltraveled.net

Customer Service Hours: Mon. – Fri. 9:00 a.m. – 6:00 p.m. (EST)

Fire Sense® and Well TraveledLiving® are registered trademarks of Well Traveled Imports, Inc. All assembly instruction presentation are the property of Well Traveled Imports, Inc® and are protected by U.S. Copyrights and trademarks. All rights reserved.