

**HUGH™ 52**

**FPS8355\*\***  
**52" Wet Location**  
**Ceiling Fan**

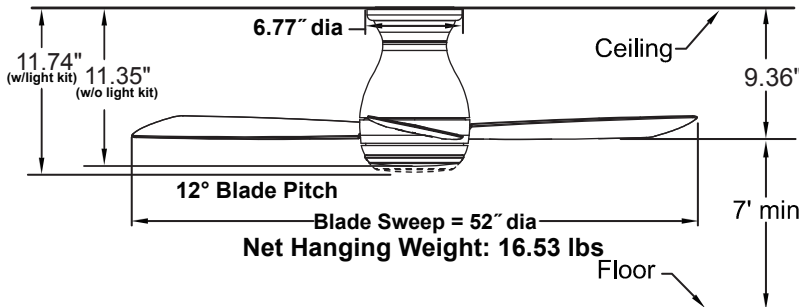

**Ceiling Bracket**  
**Width of the screw slot**

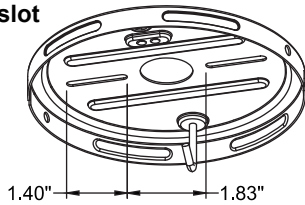

Available Finishes	
BNW	Brushed Nickel with Brushed Nickel blades and Opal Frosted Glass / Steel Cap
DZW	Dark Brone with Dark Brone blades and Opal Frosted Glass / Steel Cap
GRW	Matte Greige with Matte Greige blades and Opal Frosted Glass / Steel Cap
MWW	Matte White with Matte White blades and Opal Frosted Glass / Steel Cap

**INSTALLATION REQUIREMENTS:**

Fan must be attached to a securely anchored electrical junction box capable of withstanding a load of at least 35 lbs.

**ELECTRICAL REQUIREMENTS:**

Requires a grounded electrical supply line of 120 volts AC, 60 Hz, 15 amp circuit.

**MOTOR SPECS:**

153 x 20 AC motor is designed for optimal performance with this fan.

**BLADE SET:**

A set of three 23.5" plastic blades is included.

**CONTROL OPTIONS:**

CW60WH-8332-8355 wall control is included.

Switch control has 3 fan speeds, light levels and off button. The reverse switch is inside the light kit.

Optional BTCR9, CRL4WH and CRL8TS hand-held remote controls with receiver units are available—sold separately.

Instructions are provided with each control.

**LIGHTING OPTIONS:**

One 18-watt LED included.

**LOCATION USE:**

Fan is rated for dry, damp and wet locations.

**Fan Airflow / Energy Efficiency Info (120V)**

Fan Speed	Max RPM	CFM	CFM / Watts	Amps	Watts
High	200	5838	114	0.42	51
Med	146	4360	150	0.32	29
Low	89	2867	217	0.21	13

**Light Bulb Information (120V)**

Bulb Type	Watts	QTY	Lumens Amount	Color Temp	CRI
LED	18	1	1440	3000	80%