

PRODUCT NAME: Scepter 10-Light Rectangular
ITEM NUMBER: E32779

Please consult your electrician for hanging fixture and wiring.

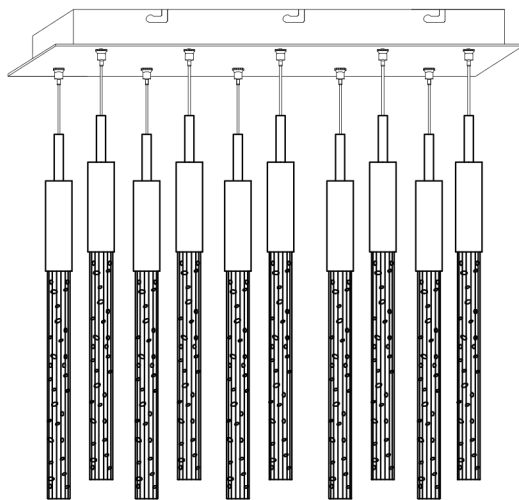

The fixture is designed to dim with a standard Triac forward phase dimmer. Dimming levels will vary by dimmer.

Below is a list of recommended dimmers:

- Lutron MACL-153M
- Lutron DVL-153P
- Lutron SCL-153P
- Leviton IPL06-10Z
- Leviton 6674-POW

Due to inrush current wattage should not exceed 150 watts of product for a 600 watt dimmer.

WARNING: Wires need to be connected to driver found in canopy and should not connect directly to power source or a short might occur.

10-7.5W LED

IMPORTANT: Turn off the power at the main fuse or circuit breaker box before starting installation

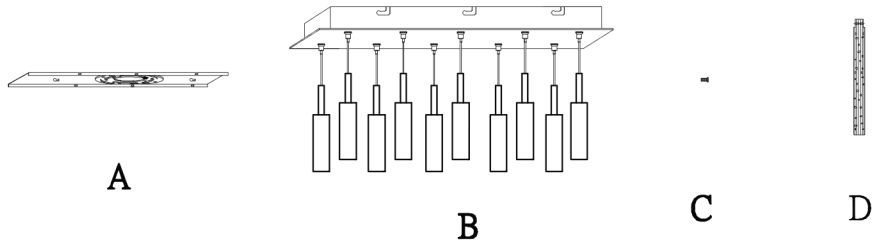

Locate all hardware & components before discarding packaging

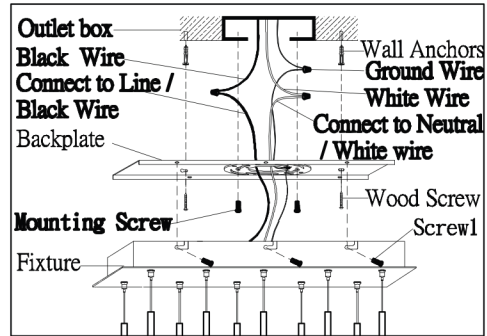
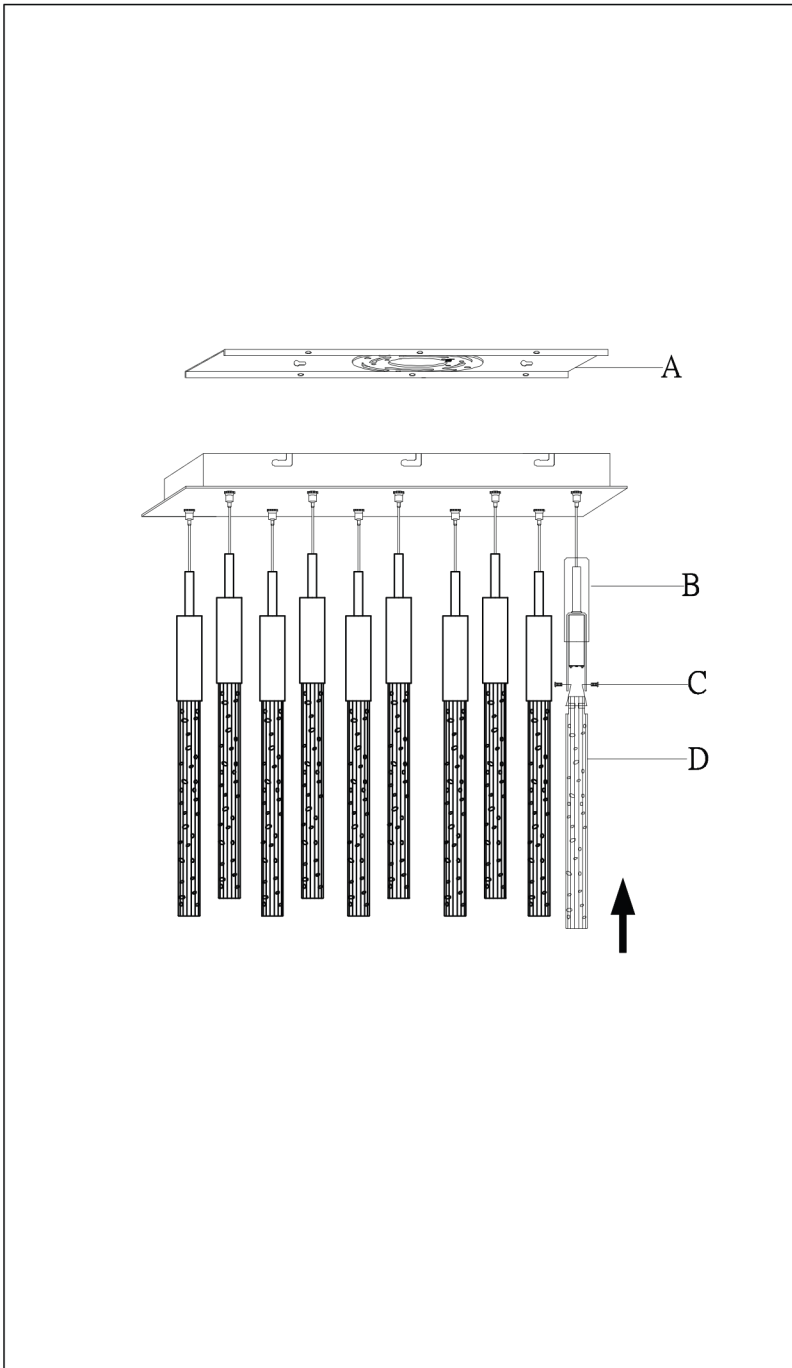

1. Remove mounting bracket (A) from fixture (B) and install to electrical box
2. Mark where screws at ends of bracket meet the ceiling.
3. Remove mounting bracket from ceiling.
4. Drill holes using 3/16"± drill bit where marked.
5. Install mounting bracket to outlet box and attach anchors to secure bracket at ends.
6. Wire fixture to wires in outlet box. Green wire is for ground.

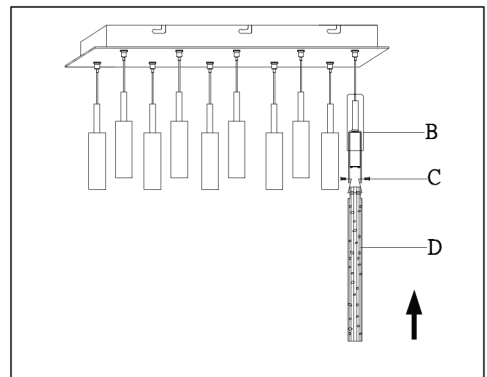

7. Carefully remove packaging from fixture.
8. Adjust wire length to desired mounting height, and tighten strain relief screws to secure.
9. Attach glass (D) using set screws (C).

Cleaning & Care:

Clean with soft cloth and a mild detergent.
Do not use abrasive cleaner.

Pendant Wires

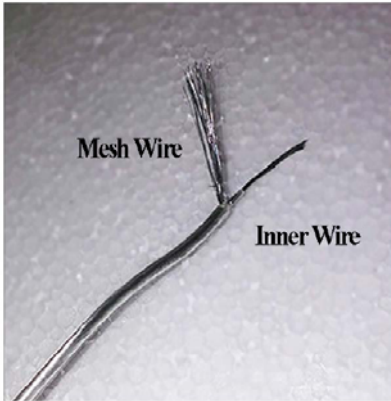

Driver Wires

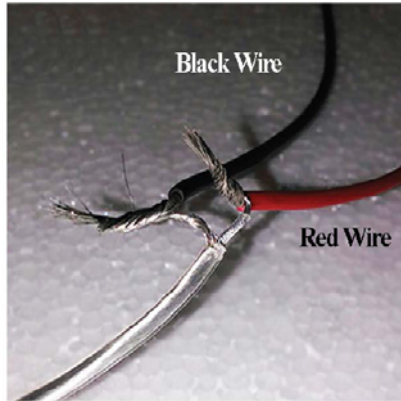

Pendant	Driver
Inner Wire (+)	Driver Red (+)
Outer Mesh (-)	Driver Black (-)

Step 4. If wires are cut in the process of adjusting the height, please note the pendants consist of an outer mesh wire(ground) and inner (Live) wire that must be separated before re-joining with the driver output wires. Pendants are wired in series to the driver, as shown below

