



Product Specifications for E20691-PC

Job Name:	Job Type:
Quantity:	Comments:



E20691-PC
Kriss Kross LED Wall Sconce

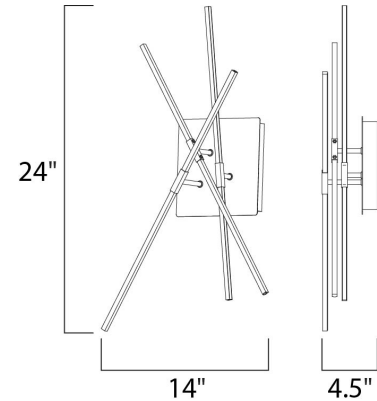

Finish
Polished Chrome

Glass/Shade

Product Category
Wall Sconce

Lamping

Number of Bulb(s)	3
Light Type	LED
Bulb Type	LED
Max Bulb Wattage	3+3
Max Fixture Wattage	17.1
Rated Life	N/A
Rated Lumens	±1,197
Color Temp	±3,000 K
Bulb(s) Included	Integrated
Light Up/Down	N/A
Beam Spread	N/A
CRI	N/A
Photo Cell Included	N/A
Ballast/Driver/Transformer	Yes
Dimmable	Standard/Lutron [®] CL or Leviton [®] LED Recommended

Measurements

Width	14.00"
Height	24.00"
Length	N/A
Extension	4.50"
Back Plate Width	N/A
Back Plate Height	N/A
HCO	13.00"
Min Overall Height	N/A
Max Overall Height	N/A
Hanging Weight	4.40 lb(s)
Height Adjustable	No
Slope	N/A
Chain Length	N/A
Wire Length	N/A
Canopy Width	N/A
Canopy Height	N/A
Canopy Length	N/A

Shipping

Carton Weight	5.50 lb(s)
Carton Width	10.63"
Carton Height	7.68"
Carton Length	16.54"
Carton Cubic Feet	N/A
Master Pack	6
Master Pack Weight	35.20 lb(s)
Master Pack Width	17.32"
Master Pack Height	23.62"
Master Pack Length	24.02"
Master Cubic Feet	N/A
UPS Shippable	Yes

Certification

Safety Rating	Dry
Energy Star	No
CA Title 24	No
CA Title 20	No
ADA	No

Other

UPC Code	845094076186
Material	Acrylic+Aluminum

Equivalents

Incandescent Watts	N/A
Fluorescent Watts	N/A

ET2 Contemporary Lighting and all designs, logos and images © 2015 ET2 Contemporary Lighting. All Rights Reserved. ET2 Contemporary Lighting reserves the right, at any time, to make changes in the design and/or construction of the product including the discontinuation of product without prior notice. Color may vary from what is pictured above due to limitations inherent to photographic processes. Always consult a qualified, licensed electrician before installation of any product weighing 35 pounds or more. We recommend that a qualified, licensed electrician do the installation. Always install to a mechanically sound structure.