

EL527HE26ICA EL527H26ICDA

5" Compact Fluorescent Vertical Downlight
IC Airtight
Housing Adjusts 1 3/8" to Accomodate
Ceiling Thickness

PROJECT INFORMATION:

Project Name: _____

Fixture Type: _____

Date: _____

DIMENSIONS

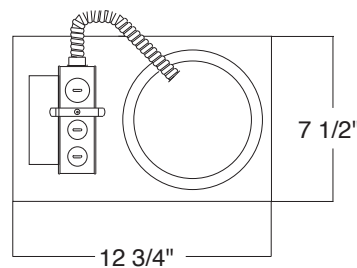
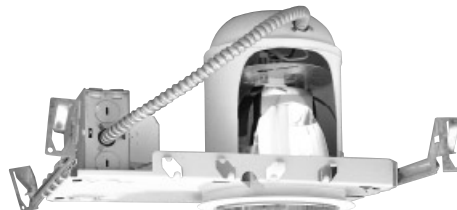
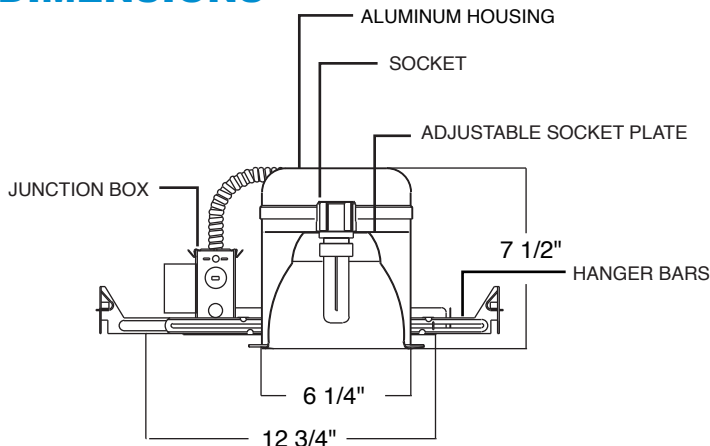

PRODUCT SPECIFICATIONS

Housing Features: Single wall construction. Thermally protected electronic ballast.

Adjustable socket bracket allows the use of different lamp types and sizes as well as proper and consistent lamp positioning.

EL527HE26ICA & EL527H26ICDA for use in insulated ceilings.

EL527HE26ICA & EL527H26ICDA meet restricted air flow requirements per ASTM E283 standards.

Lamp: Designed for (1) 26W Quad Tube or Triple Tube compact fluorescent lamp.

Reflector: Clear or Gold aluminum reflector.

EL527HE26ICA = (1) 26W 4 Pin Quad/Triple 120V Electronic Ballast

EL527H26ICDA = (1) 26W 4 Pin Quad/Triple 120/277V Dimming Ballast

Contact ELCO Lighting for details on various types of dimming ballasts available.

IECC and California Title 24 Compliant with frame gasket (included).

INSTALLATION

Junction Box: Pre-wired junction box provided with 1/2" and 3/4" knockout. U.L. listed/C.U.L. listed: for through branch wiring, maximum (8) No. 12 AWG branch circuit conductors (4 in, 4 out). Junction box provided with removable access plates. 4 Romex Cable knockouts with integral strain relief clips for easy installation.

Mounting: Hanger bars span 24" joists can be repositioned 90 degrees.

Mounting Frame: Stamped galvanized steel material for rust and corrosion resistance.

Labels:

- U.L. listed for damp locations.
- U.L. listed for feed through.
- U.L. listed for direct contact with insulation.

CATALOG NUMBER

Example: EL527HE26ICA - ELA599SC
See trim page for variety of trims available