

# EL99IC

## EL99ICA (air tight)

4" Line Voltage double wall IC housing with thermal protector. For use in insulated ceilings.

### PROJECT INFORMATION:

Project Name: \_\_\_\_\_

Fixture Type: \_\_\_\_\_

Date: \_\_\_\_\_

### DIMENSIONS

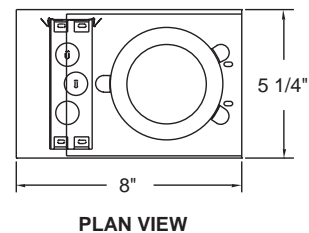
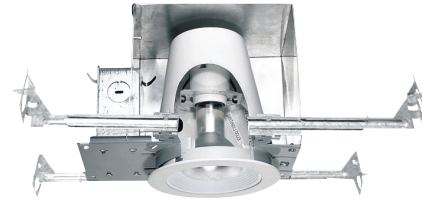
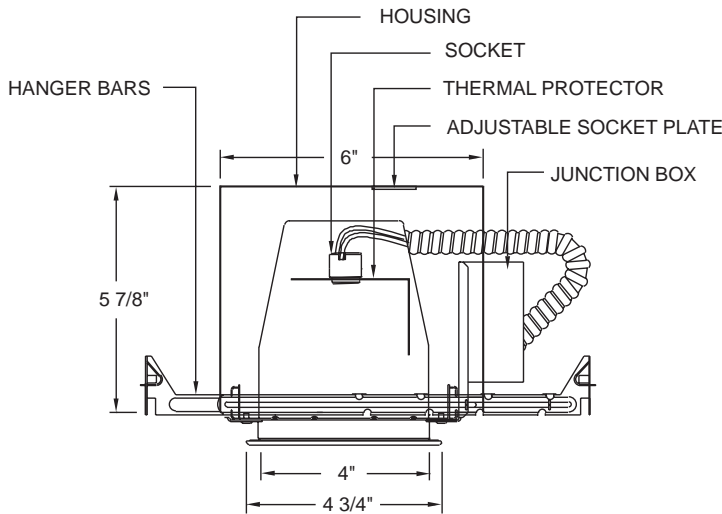

### PRODUCT SPECIFICATIONS

**Housing Features:** For use in insulated ceilings. Integral thermal protector guards against improper lamping. Double wall aluminum construction.

The **EL99ICA** housing meets restricted air flow requirements.

Adjustable socket bracket allows the use of different lamp types and sizes as well as proper and consistent positioning.

**Lamp:** 120V, 75W Maximum.

**Lamp Holder:** Medium base socket.

**Trim Ring:** Polycarbonate trim ring, metal trim ring, designed to conceal ceiling cutout.

### INSTALLATION

**Junction Box:** Pre-wired junction box provided with 1/2" and 3/4" knockout. U.L. listed/C.U.L. listed: for through branch wiring, maximum (8) N<sup>o</sup>. 12 AWG branch circuit conductors (4 in, 4 out). Junction box provided with removable access plates.

**Mounting:** Hanger bars span 24" joists and can be repositioned 90 degrees.

**Mounting Frame:** Stamped steel material and painted for corrosion resistance.

**Labels:**

- U.L. listed for damp locations.
- U.L. listed for feed through.
- U.L. listed for direct contact with insulation.

### CATALOG NUMBER

**Example:** EL99IC-EL99B

See trims page for variety of trims available.