



QUATRA LUX

SHOWER ENCLOSURE INSTALLATION INSTRUCTIONS

IMPORTANT

DreamLine™ reserves the right to alter, modify or redesign products at any time without prior notice. For the latest up-to-date technical drawings, manuals or any other details please refer to the support.BathAuthority.com web page.

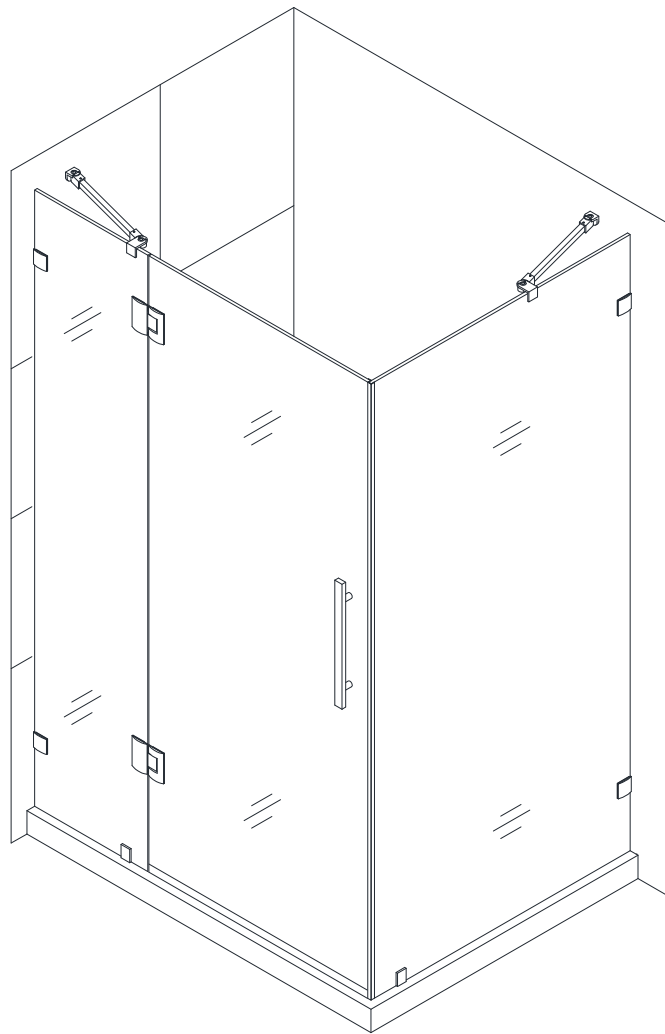

Please read these instructions carefully before installing. If you have any questions regarding installation, please call our technical support specialists Monday through Friday 9:00 AM – 5:00 PM EST at Phone: [1-866-731-2244](tel:1-866-731-2244), Fax: [1-866-227-1533](tel:1-866-227-1533) or e-mail our technical support group at support@BathAuthority.com.

For more information on [DreamLine™ Shower Enclosures](http://www.BathAuthority.com) please visit www.BathAuthority.com

Preparation

1. After opening all boxes and packages, read this introduction carefully. Check that all of the needed parts are included in the package by marking all the components on the "Detailed Diagram of Shower Door Components". Examine boxes and packages for shipping damage. If the unit has been damaged, has a finishing defect, or has missing parts, please contact our customer support department within 5 business days of the delivery date. Please note that **DreamLine™ will not replace any damaged products or missing parts free of charge after 5 business days or if the product has been installed.** Feel free to contact DreamLine™ if you have any questions.
2. **Please note that you should consult your local building codes with questions on installation compliance standards. Building and plumbing codes may vary by location, and DreamLine is not responsible for code compliance standards for your project and will not accept any returns.**
3. Please ensure that prior to the installation the installation surface is leveled and solid and will be able to support the total weight of the unit. Also make sure the walls are at right angles. Irregular installation surface level or improper angle of side walls will result in serious problems for your installation. Please, note that some adjustments and drilling might be necessary during the installation process.
4. This unit has to be installed against a finished floor and walls.
5. **Please, NOTE! This door does not have out-of-plumb adjustment. Make sure your walls are at right angles.**

Tools Required

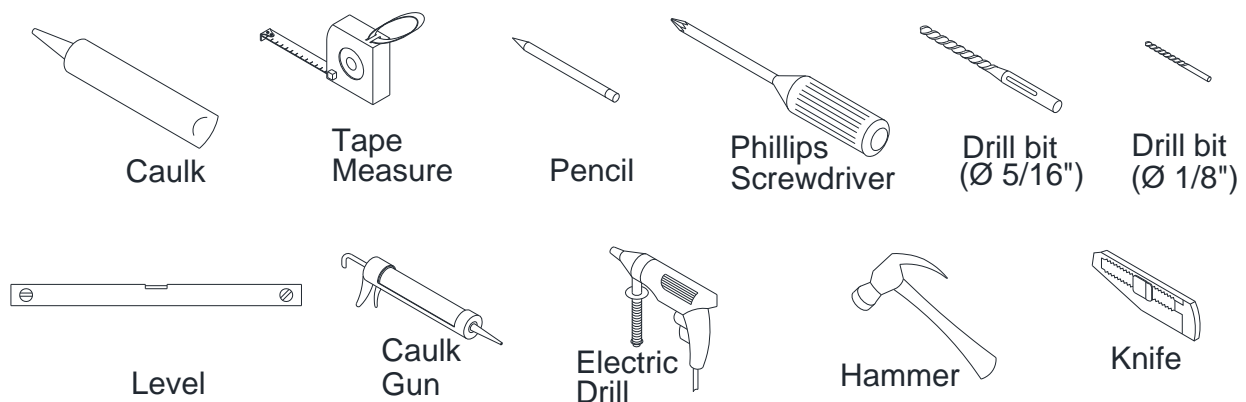

Detailed Diagram of Shower Enclosure Components

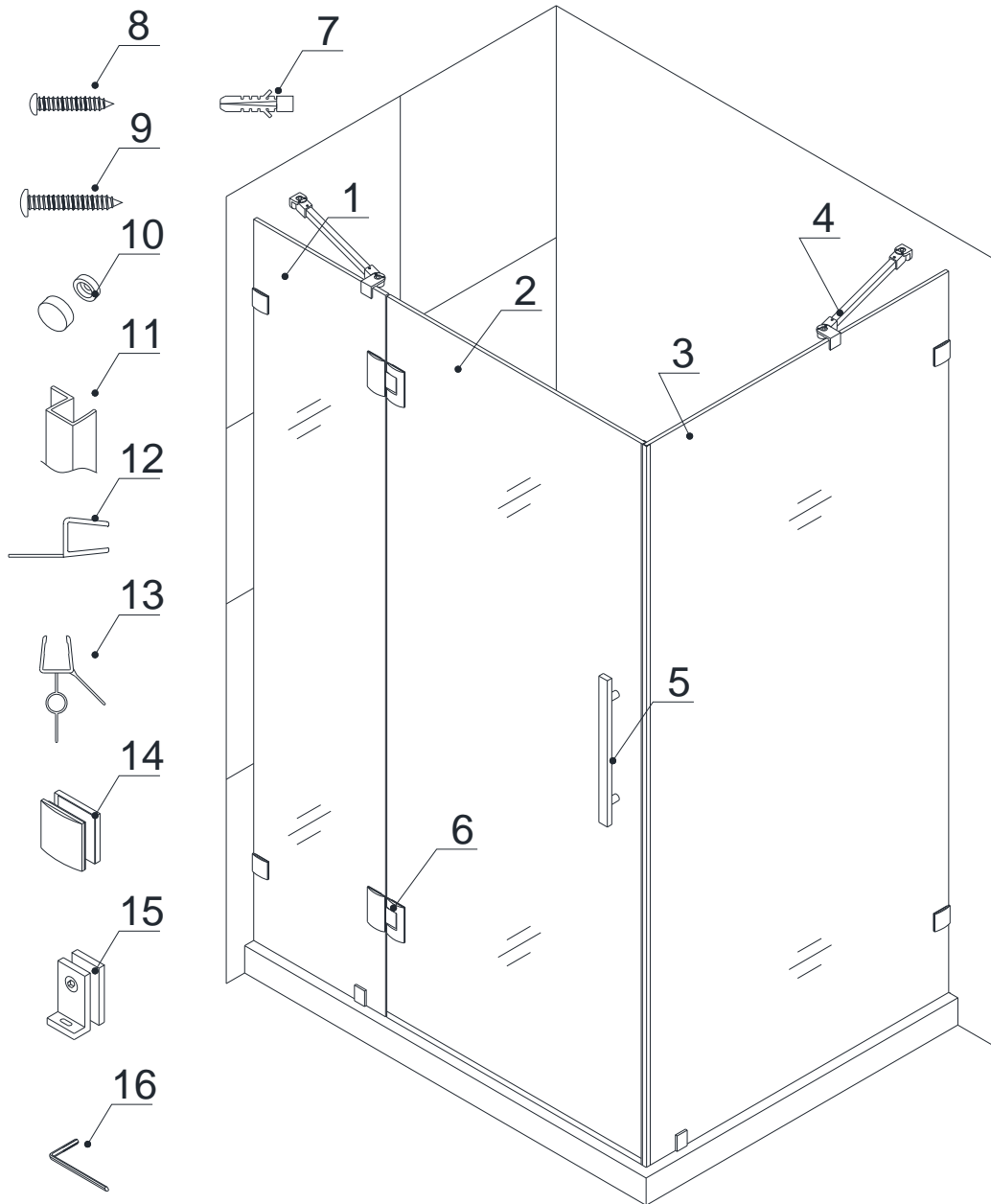

Packing List

01	Stationary glass panel	1pc	09	Big head screw ST4.2×55	6pcs
02	Glass door	1pc	10	Decorative cover	2pcs
03	Return glass panel	1pc	11	Side anti-water strip	1pc
04	Support bar	2pcs	12	Flanged anti-water strip	1pc
05	Handle	1pc	13	Bottom anti-water strip	1pc
06	Hinge	2pcs	14	Wall bracket	4pcs
07	Wall anchor	6pcs	15	Bottom bracket	2pcs
08	Round head screw ST4.2×25	2pcs	16	4mm hex wrench	1pc

NOTE: Unpack your unit carefully and inspect it. Lay it out and identify all parts using parts diagram and part list in your manual as a reference. Before discarding the carton, check for small hardware bags that tend to fall to the bottom of the box. If any parts are damaged or missing, please contact DreamLine™ for replacement.

NOTE: Retain these installation instructions for future reference.

Shower Enclosure Installation

1. Assemble the **Wall brackets (14)** onto the **Stationary glass panel (01)** and the **Return glass panel (03)**.

See Fig. 1 for details.

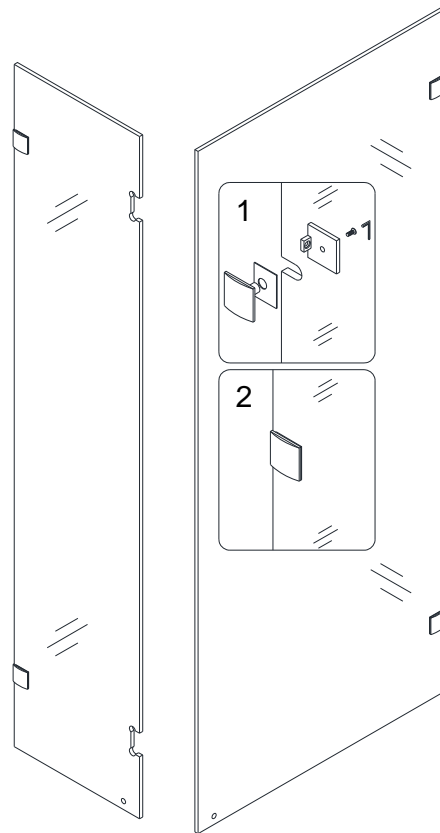

Fig. 1

2. Draw the line on the wall according to your Shower Enclosure model size.

Model No	W1	W2
SHEN-GL1311-343410	34 3/8"	34 3/8"
SHEN-GL1311-363610	32 3/8"	46 3/8"
SHEN-GL1311-383810	34 3/8"	46 3/8"

Place the assembled **Stationary glass panel (01)** and **Return glass panel (03)** on the shower base, butt them up against the wall and level them vertically.

See Fig. 2 for details.

Note: Make sure the **Glass panels** are absolutely vertical.

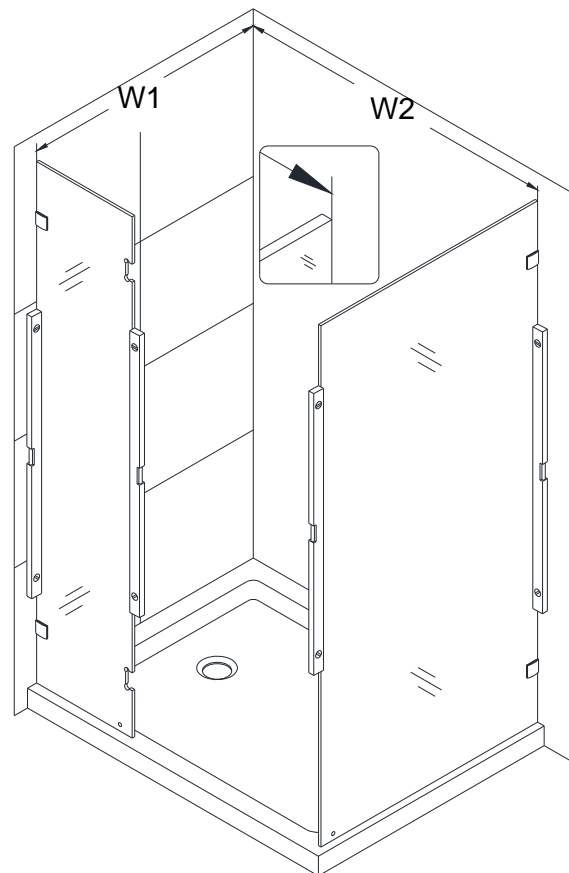

Fig. 2

3. Make sure the distance between the Glass panels is $23\ 7/8"$.

See Fig. 3 for details.

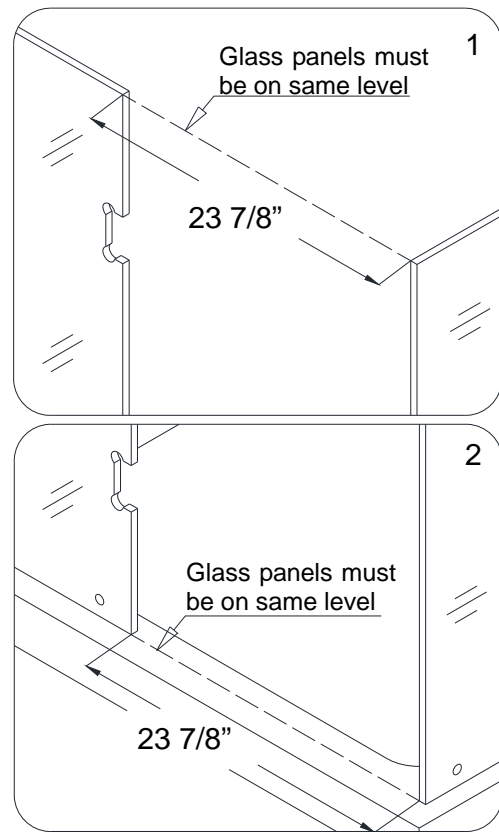

Fig. 3

4. Outline the position of the **Wall brackets (14)** on the wall.

Set the **Stationary glass panel (01)** and **Return glass panel (03)** aside.

Remove the **Wall bracket** from the **Glass panels** and by placing it back to the outlined position mark the drilling holes on the wall.

Drill the holes in the wall using $\text{Ø } 5/16"$ drill bit and insert the **Wall anchors (07)** for the **Wall brackets**.

Fasten the **Wall brackets** to the wall using the **Big head screw ST4.2×55 (09)**.

See Fig. 4 for details.

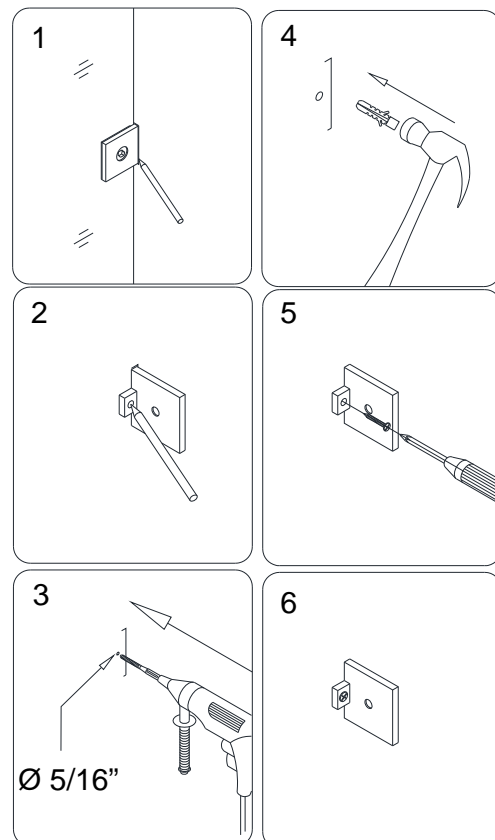

Fig. 4

- Place the **Stationary glass panel (01)** and **Return glass panel (03)** back into the designated position, assemble the **Wall brackets (14)** and tighten the bolts.

See Fig. 5 for details.

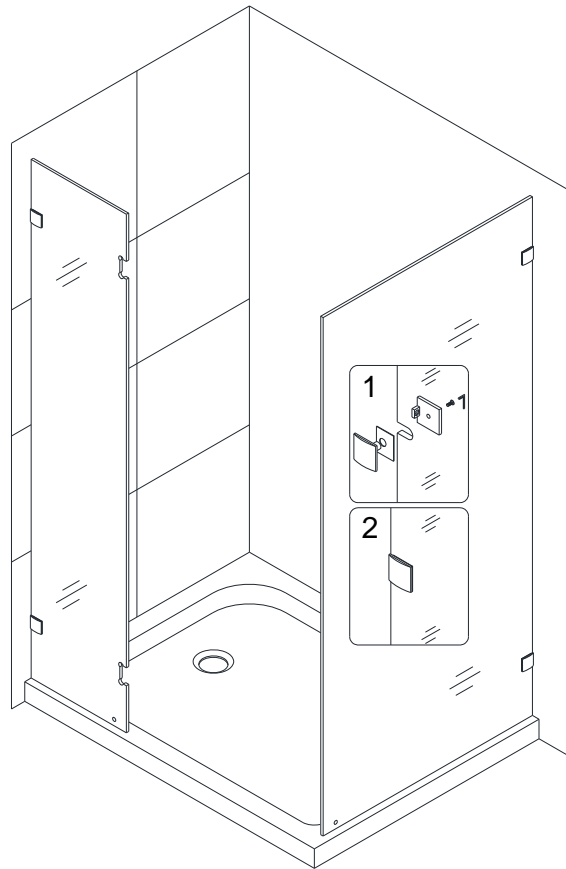

Fig. 5

- Locate the **Support bar (04)**.

Adjust the bar to a proper position on the glass and the wall. Level it horizontally. Hold it firmly and outline the bracket's position on the wall. Remove the **Support bar** and detach the wall bracket from it. Place the wall bracket against its outlined position on the wall and mark the drilling hole.

Drill the hole using $\text{Ø } 5/16''$ drill bit, insert the **Wall anchor (07)** and fasten the wall bracket to the wall with the **Big head Screw ST4.2×55 (09)**. Attach the **Support bar** to the wall as shown on Fig. 6.5 and tighten the set screws and the glass holding screw to secure the glass.

See Fig. 6 and Fig. 7 for details.

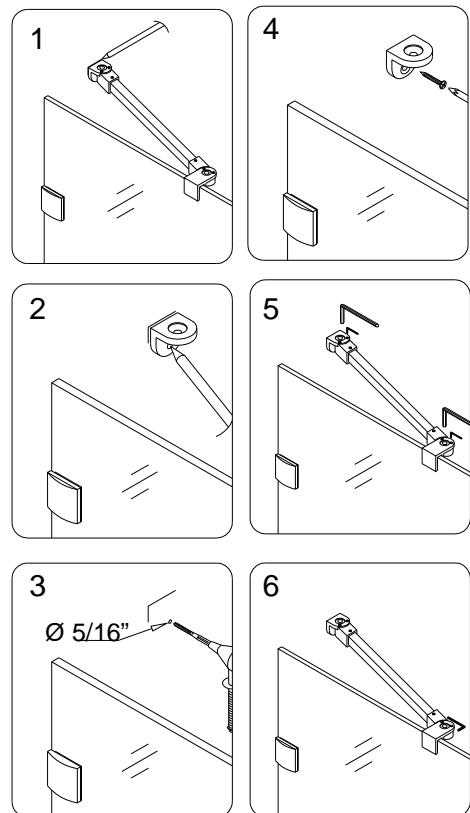

Fig. 6

- Repeat the Step 6 to mount the second support bar.

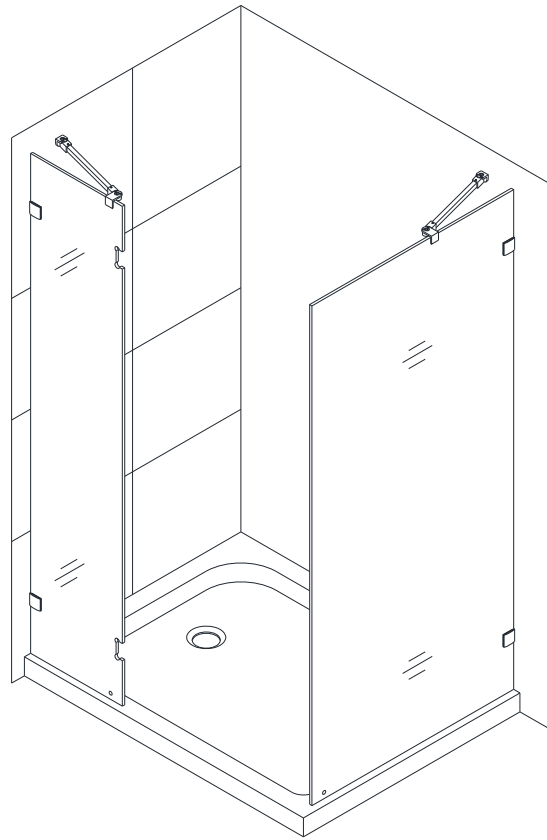

Fig. 7

- Attach the **Hinges (06)** to the **Stationary glass panel (01)** with the decorative bolts facing inside the shower. Bring the **Glass door (02)** into the Shower base between the two stationary glasses. Level up the **Glass door** next to the **Stationary glass panel** and fasten the hinges on the **Glass Door**. Make sure the top edges of the **Glass door** and both **Glass panels** are aligned.

See Fig. 8 and Fig. 9 for details.

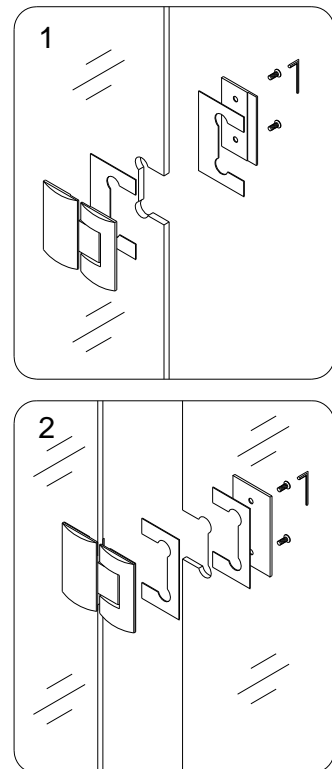

Fig. 8

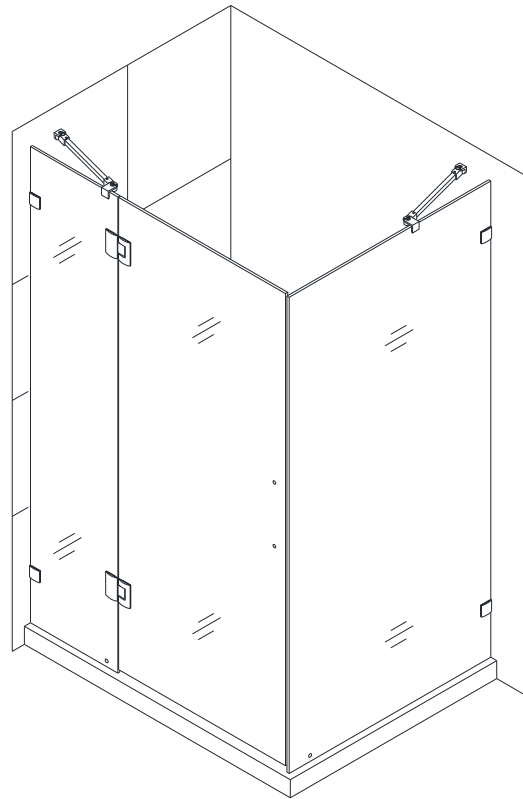

Fig. 9

9. Get three measurements:

- from the top edge of the **Glass door (02)** to the top edge of the upper **Hinge (06)**;
- from the bottom edge of the upper **Hinge** to the top edge of the bottom **Hinge**;
- from the bottom edge of the bottom **Hinge** to the surface of the shower base Cut the **Flanged anti-water strip (12)** according to the measurements.

Press the cut strips on to the vertical edge of the **Glass door**. Press the **Side anti-water strip (11)** on the vertical edge of the **Return glass panel (03)** with the flange facing the door.

Press the **Bottom anti-water strip (13)** on the bottom edge of the Glass door.

Install the **Handle (05)** to the **Glass door**.

See Fig. 10 for details.

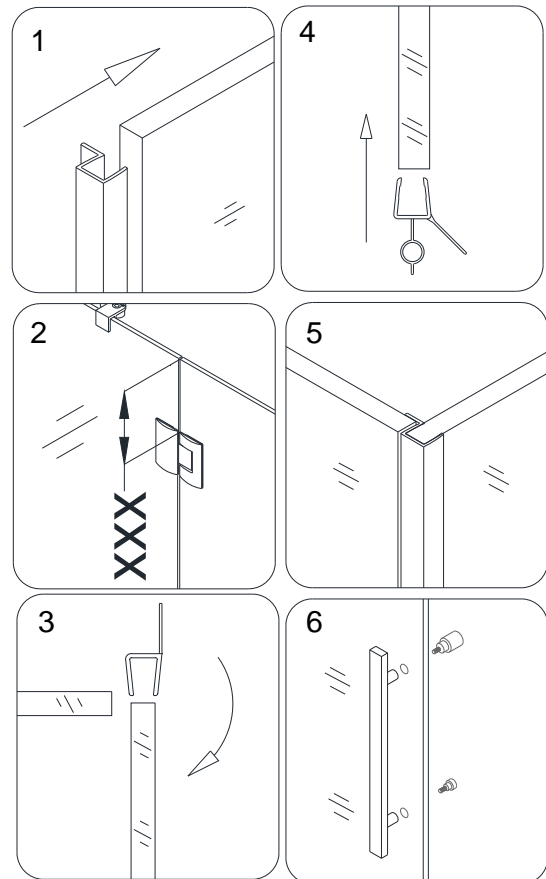

Fig. 10

10. After final adjustment is complete secure both **Stationary glasses**.

Assemble the **Bottom brackets (15)** onto the bottom of the **Stationary glasses**.

Drill the holes in the Shower base through the holes in the flange of the **Bottom brackets** using $\text{Ø } 1/8''$ drill bit. Fasten the bottom brackets with the **Round head screw ST4.2×25 (08)**.

Cover the screw with the **Decorative covers (10)**.

See Fig. 11 for details.

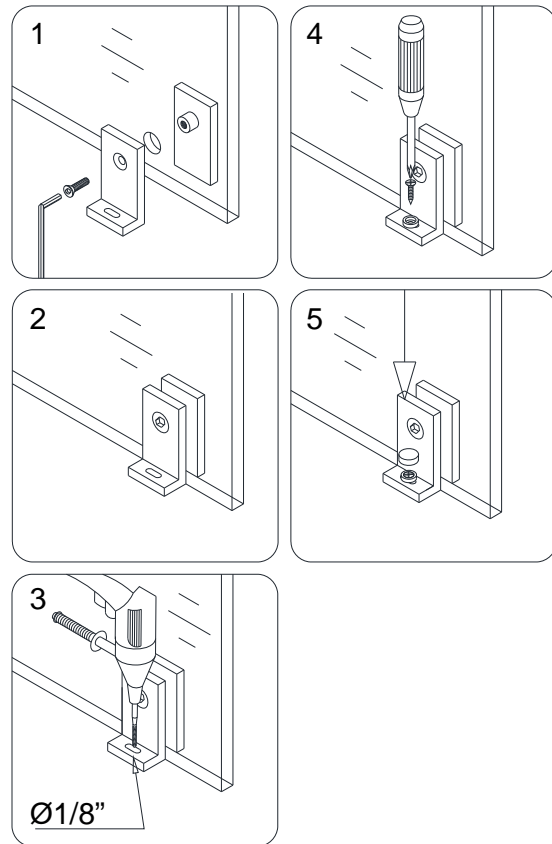

Fig. 11

11. Apply the sealant along the connection of the stationary glasses with the walls and the Shower base.

See Fig. 12 for details.

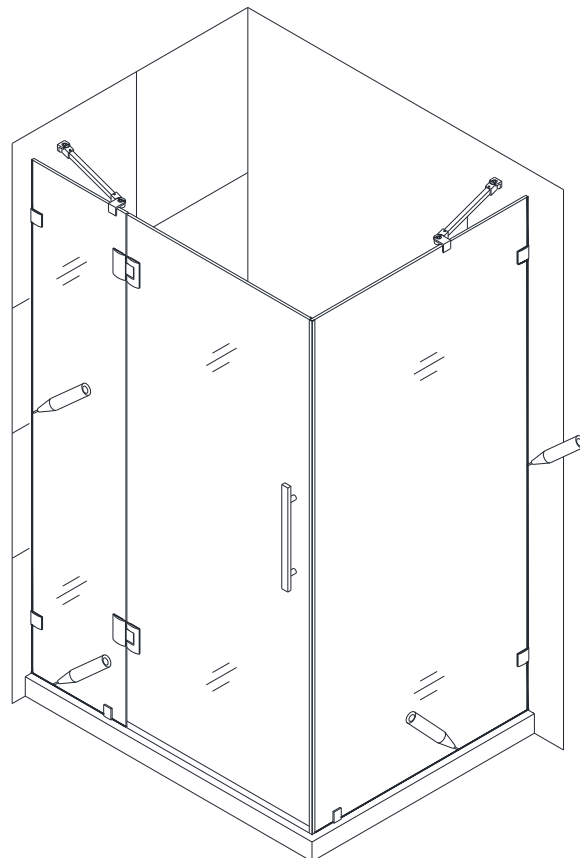

Fig. 12

Product Maintenance

To insure long lasting life for your acrylic back walls, wipe them off after each use with a soft cloth. To clean the acrylic back walls use non-abrasive sprays or cream based cleaners. Never use abrasive cleansers, metal brushes or scrapers that could scratch or dull the surface.

To insure long lasting life for your glass shower products, wipe them off after each use with a soft cloth. Rinse and wipe of the glass using either soft cloth or squeegee to prevent soap buildup. Never use abrasive cleaners and cleaning products that contain scoring agent because this may scratch the surface. Never use bristle brushes or abrasive sponges.

To assure a long lasting finish wipe off the metal parts after each use with a soft cloth. Do not use abrasive cleaners or cleaning products containing ammonia, bleach or acid. If accidentally used, rinse the surface as soon as possible to prevent finish peeling or corrosion. After cleaning the shiny finishes, rinse thoroughly and wipe dry with soft cloth. Clean stainless steel surfaces at least once a week. When applying stainless steel cleaner or polish, work with (not across) the grain. Never use abrasive sponge or cloth, steel wool or wired brushes.

DREAMLINE™ EXCLUSIVE LIMITED WARRANTY AS OF MAY 6, 2013

This warranty extends only to the original owner/end-user for household use only and is not transferable to a subsequent owner. This warranty extends for a designated period of time, so long as it remains in use in its original place of installation. This warranty applies only to DreamLine products purchased from an authorized dealer in United States or Canada. Proof of purchase (original sales receipt) from the original consumer purchase must be provided with all warranty claims.

IN NO EVENT SHALL THE LIABILITY OF DREAMLINE EXCEED THE PURCHASE PRICE OF THE UNIT.

DreamLine products must be installed by a fully insured and licensed professional. Installation of DreamLine product by anyone other than fully insured licensed professionals shall **VOID THE WARRANTY**. DreamLine recommends that such licensed professionals have experience in the installation of bathroom products. Installation of certain products, including, without limitation, glass products (i.e., shower and tub doors) by an inexperienced installer may result in glass breakage and, consequently, cause personal injury or death.

PARTS ONLY WARRANTY

This warranty is extensive in that it covers replacement of all defects. LABOR CHARGES AND/OR DAMAGE INCURRED IN INSTALLATION, REPAIR, OR REPLACEMENT, AS WELL AS ANY OTHER KIND OF LOSS OR DAMAGE ARE EXCLUDED

COMMERCIAL USE AND OTHER EXCLUSIONS

This warranty excludes all industrial, commercial and business usage, whose purchasers are hereby extended a one (1) year limited warranty from the date of purchase for shower and tub doors, a three (3) month limited warranty from the date of purchase for vanities and sinks, with all other terms of this warranty applying except the duration of the warranty.

DREAMLINE JETTED AND STEAM SHOWER CABINS, DREAMLINE SHOWER COLUMNS AND DREAMLINE SHOWER SEATS ARE NOT INTENDED FOR COMMERCIAL USE AND THERE IS NO WARRANTY EXTENDED FOR THESE PRODUCTS FOR COMMERCIAL USE.

DreamLine hereby disclaims all warranties for products sold as dealer or store displays. DreamLine hereby disclaims all warranties for products used outside of the United States or Canada whether expressed or implied, including but not limited to the implied warranties of merchantability and fitness for a particular purpose.

WARRANTY TERMS

DreamLine will, at its election, repair or replace the product found by DreamLine in its sole judgment, to be defective within the warranty period under normal residential use and maintenance. The replacement of a product is limited to supplying a replacement product or part (same as existing or if not available, comparable product). DreamLine warranty obligation shall be discharged upon tender of parts, replacement or repair of the product. Purchaser's refusal to accept the tender terminates all warranty obligations and **VOIDS THE WARRANTY**. Cost of freight for returning products to DreamLine for repairs or replacement under this limited warranty are the responsibility of the customer. Cost of freight associated with shipping of replacement product or parts to the customer may be charged to customer. Any product replaced or repaired during the warranty period will be covered only for the remaining period of the original warranty. In no event will DreamLine be liable for costs of repair or replacement of any installation material, including but not limited to tiles, marble, etc.

DREAMLINE IS NOT RESPONSIBLE FOR INSTALLATION, REMOVAL OR REINSTALLATION COSTS OF ANY PRODUCT REQUIRING WARRANTY SERVICES.

Any modification or alteration of any DreamLine products will void the warranty. DreamLine product installations and repairs must be performed by either a DreamLine authorized agent or a licensed, insured and experienced professional contractor - installation or repairs performed by any other party shall void the warranty. This warranty shall not apply to breakage or damages caused by normal wear and tear, fault, carelessness, abuse, misuse, misapplication, improper maintenance, alteration or modification of the unit, as well as chemical or natural corrosion, accident, fire, flood, act of God or any other casualty. Improper care and cleaning will void the warranty. Use of cleaners containing abrasive cleansers, ammonia, bleach, acids, waxes, alcohol, solvents or other products not recommended for chrome or similar finish, glass or acrylic will void the warranty. For additional product maintenance instructions please refer to product installation manual. DreamLine is not responsible for any issues arising in connection with errors or omissions in information provided on DreamLine's websites. The warranty does not extend to any non-DreamLine plumbing or components installed by installers, end users or by any party other than DreamLine.

THE FOREGOING WARRANTIES ARE IN LIEU OF ALL OTHER WARRANTIES, EXPRESSED OR IMPLIED, INCLUDING BUT NOT LIMITED TO THE IMPLIED WARRANTIES OF MERCHANTABILITY AND FITNESS FOR A PARTICULAR PURPOSE. BATH AUTHORITY LLC ("DREAMLINE") AND/OR SELLER DISCLAIMS ALL LIABILITY FOR SPECIAL, INCIDENTAL OR CONSEQUENTIAL DAMAGES. DREAMLINE IS NOT LIABLE FOR PERSONAL INJURIES OR DEATH TO ANY PERSON OR FOR ANY DIRECT, SPECIAL, INCIDENTAL OR CONSEQUENTIAL DAMAGE, LOSS OF USE, LOSS OF TIME, LOSS OF PROFITS, INCONVENIENCE, INCIDENTAL EXPENSES, LABOR OR MATERIAL CHARGES, OR ANY OTHER COSTS RESULTING FROM THE USE OF ITS PRODUCTS OR PERTAINING TO THE APPLICATION OF THE PRESENT WARRANTY, OR RESULTING FROM THE REMOVAL OR REPLACEMENT OF ANY PRODUCT OR ELEMENT OR PART COVERED BY THIS WARRANTY.

PRODUCT WARRANTY PERIODS

DreamLine is not responsible for product code compliance or for verifying building code restrictions on installation or use and any such compliance is excluded from this warranty. DreamLine reserves the right to modify this warranty at any time - such warranty modifications will not alter the warranty applicable at the time of sale of the products in question. The warranty terms for specific products for consumer (non-industrial, non-commercial, non-business use only) are:

SHOWER BACKWALL, SHOWER CABINS (JETTED & STEAM)

DreamLine warrants shower backwalls and shower cabins to be free from defects in workmanship for a period of one (1) year from initial date of purchase by the owner/end-user, contractor or builder from an authorized dealer.

SHOWER & TUB DOORS, SHOWER ENCLOSURES

DreamLine warrants shower doors, tub doors and shower enclosures to be free from defects in workmanship and materials under normal residential use for a period of five (5) years from the initial date of purchase by the owner/end-user, contractor or builder from an authorized dealer. Warranty for plastic strips shall be limited to one (1) year. Warranty for any part in Oil Rubbed Bronze finish shall be limited to one (1) year.

SHOWER BASES

DreamLine warrants shower bases to be free from defects in workmanship and materials under normal residential use for as long as the original consumer purchaser owns their home in which their product is installed.

SHOWER COLUMNS

DreamLine warrants shower columns to be free from defects in workmanship and materials under normal residential use for a period of one (1) year from the initial date of purchase by the owner/end-user, contractor or builder from an authorized dealer.

SHOWER SEATS

DreamLine warrants shower seats to be free from defects in workmanship and materials under normal residential use for a period of one (1) year from the initial date of purchase by the owner/end-user, contractor or builder from an authorized dealer. Warranty shall be VOID if the shower seat is not professionally installed on a properly reinforced wall.

VANITIES AND VESSEL SINKS

DreamLine warrants bathroom vanities and vessel sinks to be free from defects in workmanship and materials under normal residential use for a period of one (1) year from the initial date of purchase by the owner/end-user, contractor or builder from an authorized dealer.

STATE LAWS AND THIS WARRANTY

Some states/provinces do not allow limitations on how long an implied warranty lasts, or the exclusion or limitation of special, incidental or consequential damages, so these limitations and exclusions may not apply to you. This warranty gives you specific legal rights. You may also have other rights, which vary from state/province to state/province.

WARRANTY SERVICE

The following information will be required for you to file a Warranty claim:

1. Your name, address and telephone number
2. Product model number
3. Brief description of problem (please note that additional information such as photos may be required to fully process your warranty claim)
4. Proof of purchase

You may submit this information by e-mail, mail or fax to:

DreamLine
Warranty Service Center
75 Hawk Road
Warminster, PA 18974
F:1-866-857-3638
T:1-866-731-2244
Warranty@bathauthority.com



TEL: [866-731-2244](tel:866-731-2244)

FAX: [866-227-1533](tel:866-227-1533)

[WWW.BATHAUTHORITY.COM](http://www.BATHAUTHORITY.COM)

For more information on [DreamLine™ Shower Enclosures](http://www.BathAuthority.com) please visit www.BathAuthority.com