



AQUA UNO

TUB DOOR INSTALLATION INSTRUCTIONS

IMPORTANT

DreamLine™ reserves the right to alter, modify or redesign products at any time without prior notice. For the latest up-to-date technical drawings, manuals or any other details please refer to the support.BathAuthority.com web page.

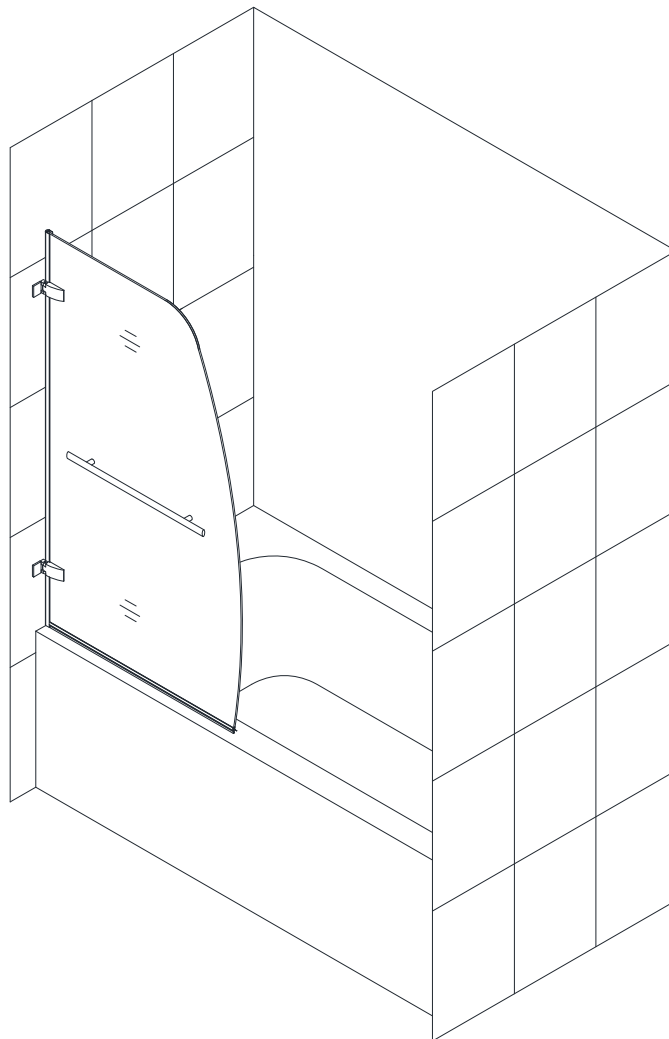

Please carefully read the instructions before installing. If you have any questions regarding installation, please call our technical support specialists Monday through Friday 9:00 AM – 5:00 PM EST at 1-866-731-8378, ext. 3 or e-mail our technical support group at support@BathAuthority.com.

For more information on [DreamLine™ Tub Doors](http://www.BathAuthority.com) please visit www.BathAuthority.com

Preparation

1. After opening all boxes and packages, read this introduction carefully. Check that all of the needed parts are included in the package, by marking all the components on the "Detailed Diagram of Tub Door Components". Examine boxes and packages for shipping damage. If the unit has been damaged, has a finishing defect, or has missing parts, please contact our customer support department within 3 business days of the delivery date. Please note that **DreamLine™ will not replace any damaged products or missing parts free of charge after 3 business days or if the product has been installed.** Feel free to contact DreamLine™ if you have any questions.
2. If this unit is going to be installed in a new construction, please, install all of the required plumbing and drainage before installing the shower. **Use a competent and licensed (if required by local code) plumber for all plumbing installation**
3. **Please note that you should consult your local building codes with questions on installation compliance standards. Building and plumbing codes may vary by location, and DreamLine is not responsible for code compliance standards for your project.**
4. Please insure that prior to the installation the installation surface is leveled and solid and will be able to support the total weight of the unit. Also make sure the walls are at right angles. While some adjustment in leveling of the door is possible, irregular installation surface level or improper angle of side walls will result in serious problems for your installation. Please, note that some adjustments and drilling might be necessary during the installation process.

Tools Required

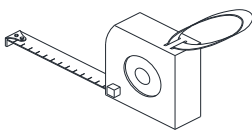

Tape Measure



Pencil



Phillips Screwdriver

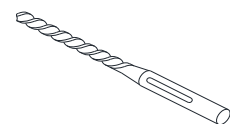

Drill bit (Ø 5/16")



Level

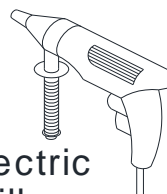

Electric Drill



Hammer

Detailed Diagram of Tub Door Components

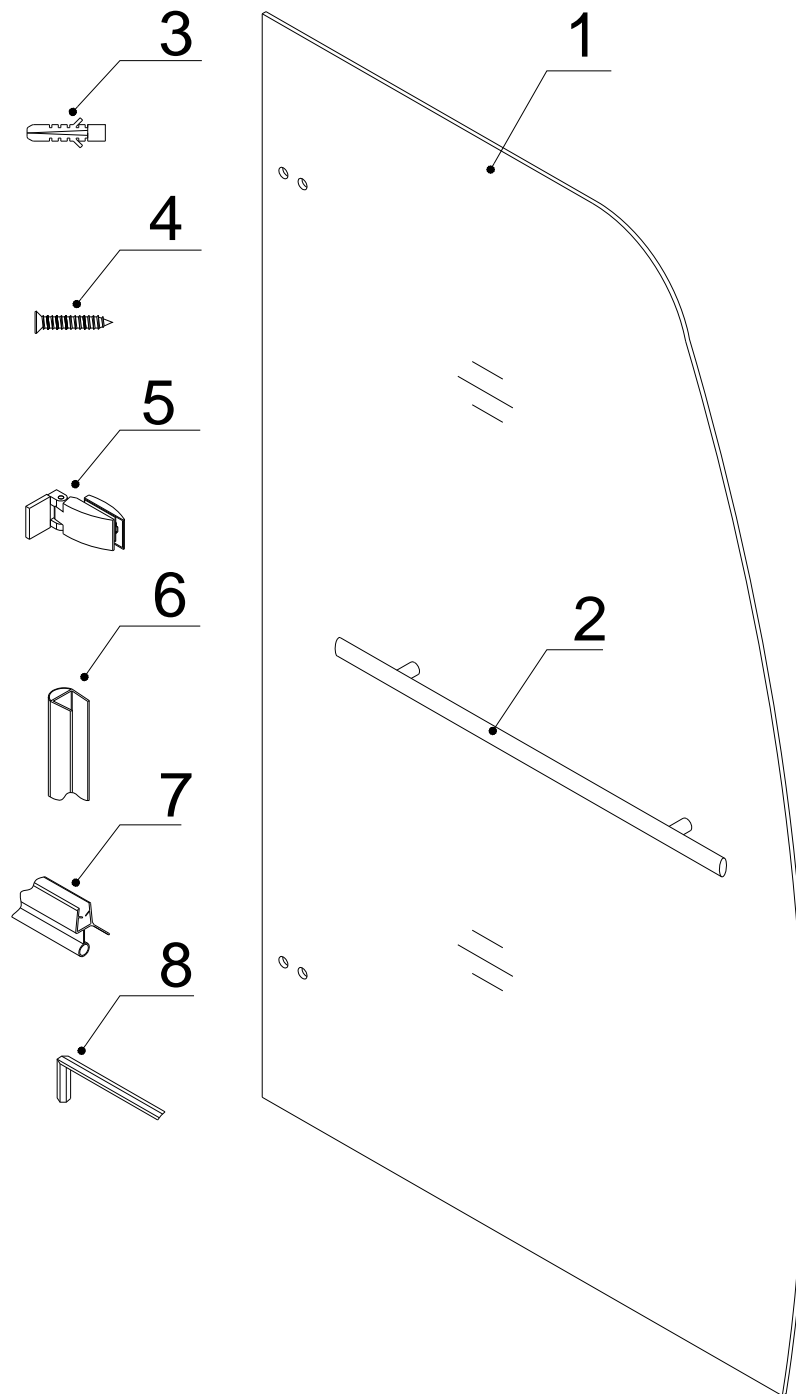

Packing List

01	Glass door	1pc	05	Hinge	2pcs
02	Handle	1pc	06	Side anti-water strip	1pc
03	Wall anchor	6pcs	07	Bottom anti-water strip	1pc
04	Flat head screw ST5×35	6pcs	08	2mm, 4mm Hex wrench	1set

NOTE: Unpack your unit carefully and inspect it. Lay it out and identify all parts using the detailed diagram and packing list in your manual as a reference. Before discarding the carton, check for small hardware bags that tend to fall to the bottom of the box. If any parts are damaged or missing, please contact DreamLine™ for replacement.

Tub Door Installation

1. Assemble the **Hinges (05)** onto the **Glass door (01)** using the predrilled holes and the bolts with the provided decorative cover.

To remove the decorative cover and reveal the bolts, loosen the set screw on the back side of the decorative cover using 2mm Hex Wrench

See Fig. 1 for details.

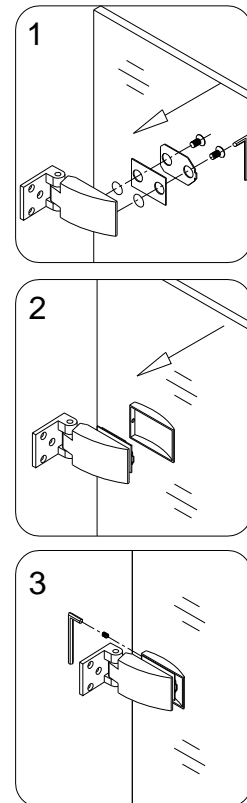

Fig. 1

2. Place a piece of flat timber (5/8" thick) on the bathtub.

Remove the decorative cover from the wall-connecting part of the hinges to expose holes for the wall connection. Use a flat screw driver to pop the decorative cover open.

Take the **Glass door (01)** with the assembled **Hinges (05)** and place it on the flat timber.

Push the door with the hinged side against the wall and adjust its position with the level.

NOTE:

Make sure that the door is leveled vertically.

See Fig. 2 for details.

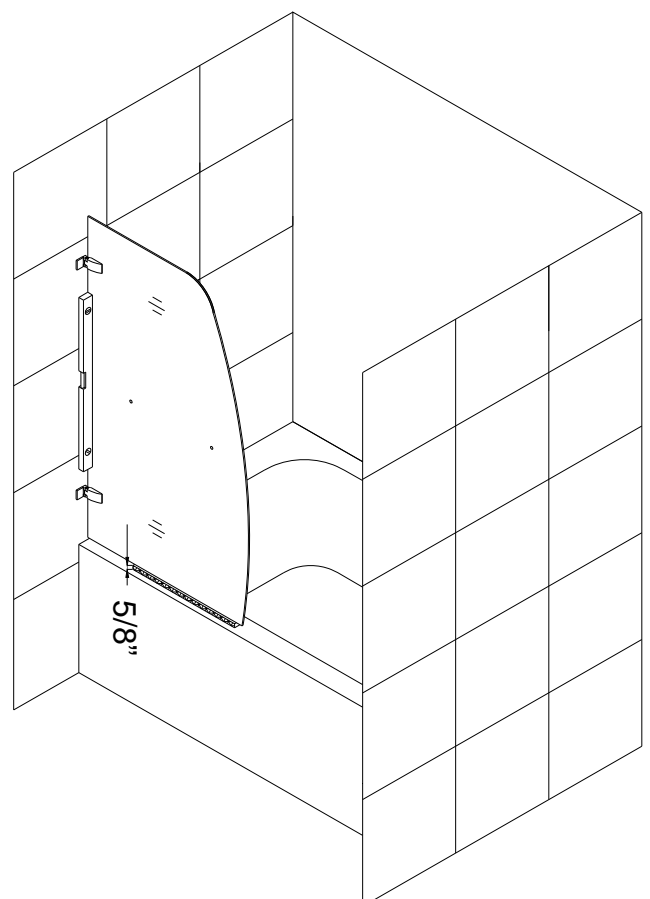

Fig. 2

3. Mark the drill holes on the wall.

Set the **Glass door (01)** aside, drill the holes using **Ø5/16"** drill bit, and insert the **Wall anchors (03)**.

See Fig. 3 for details.

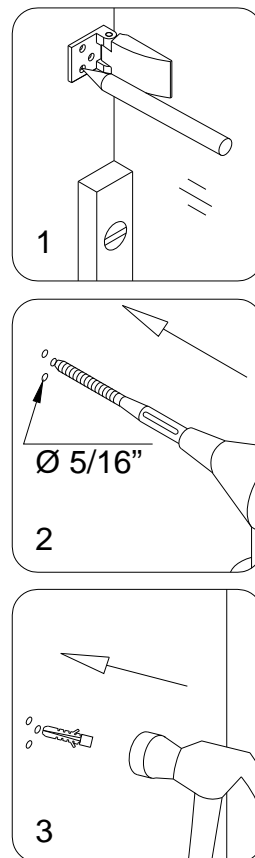

Fig. 3

4. Place the **Glass door (01)** back in position and secure the **Hinges (05)** to the wall using the **Flat head screw ST5×35 (04)**.

Snap the decorative cover back on.

See Fig. 4 for details.

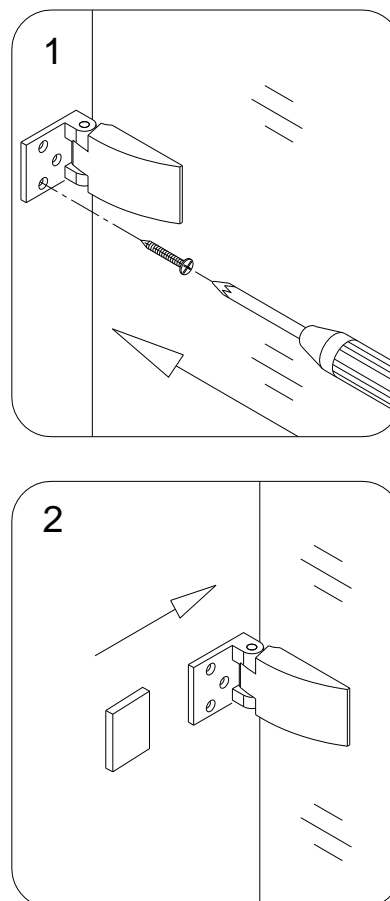

Fig. 4

5. Remove the flat timber and open the door.
Attach the **Side anti-water strip (06)** over the vertical edge of the **Glass door (01)**.
Attach the **Bottom anti-water strip (07)** over the bottom edge of the **Glass door**.
Install the **Handle (02)** using the predrilled holes on the **Glass door**.

See Fig. 5 and Fig. 6 for details.

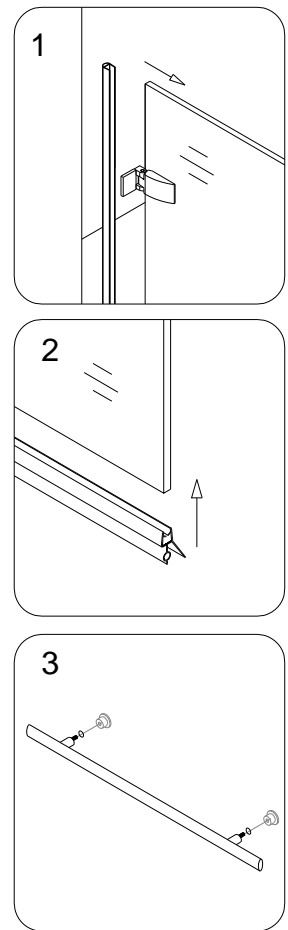

Fig. 5

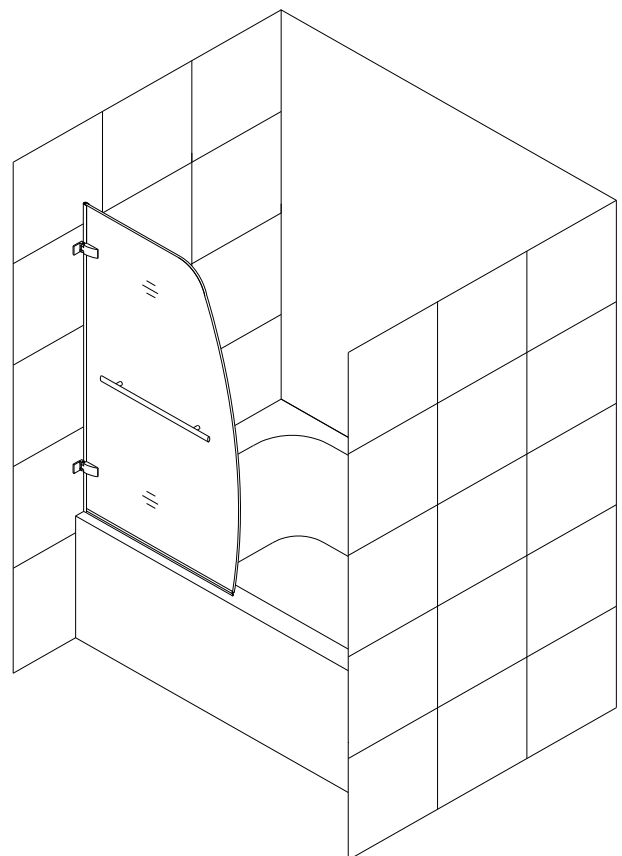

Fig. 6

Product maintenance

To insure long lasting life for your acrylic back walls, wipe them off after each use with a soft cloth. To clean the acrylic back walls use non-abrasive sprays or cream based cleaners. Never use abrasive cleansers, metal brushes or scrapers that could scratch or dull the surface.

To insure long lasting life for your glass shower products, wipe them off after each use with a soft cloth. Rinse and wipe of the glass using either soft cloth or squeegee to prevent soap buildup. Never use abrasive cleaners and cleaning products that contain scoring agent because this may scratch the surface. Never use bristle brushes or abrasive sponges.

To assure a long lasting finish wipe off the metal parts after each use with a soft cloth. Do not use abrasive cleaners or cleaning products containing ammonia, bleach or acid. If accidentally used, rinse the surface as soon as possible to prevent finish peeling or corrosion. After cleaning the shiny finishes, rinse thoroughly and wipe dry with soft cloth. Clean stainless steel surfaces at least once a week. When applying stainless steel cleaner or polish, work with (not across) the grain. Never use abrasive sponge or cloth, steel wool or wired brushes.



This is Bath Authority LLC's ("DreamLine") exclusive written warranty effective April 1, 2011

This warranty extends only to the original owner/end-user for household use only and is not transferable to a subsequent owner. This warranty applies only to DreamLine™ products purchased from an authorized dealer and installed in United States or Canada. Proof of purchase (original sales receipt) must be provided with all warranty claims. **In no event shall the liability of DreamLine™ exceed the purchase price of the unit.**

If DreamLine™ shower doors, shower enclosures and shower bases are used commercially, DreamLine™ warrants such products to be free from defects in material and workmanship for one (1) year from initial date of purchase from an authorized dealer, with all other terms of this warranty applying except duration. If DreamLine™ vanities, vessel sinks and shower columns are used commercially, DreamLine™ warrants such products to be free from defects in material and workmanship for three (3) months from initial date of purchase from an authorized dealer, with all other terms of this warranty applying except duration. **DreamLine™ Jetted and Steam Shower Cabins are not intended for commercial use and there is no warranty extended for these products for commercial use.** DreamLine™ is not responsible for loss of use or profit under any circumstances.

DreamLine™ hereby disclaims all warranties for products sold as a dealer or store displays. DreamLine™ hereby disclaims all warranties for products used outside of the United States or Canada whether expressed or implied, including but not limited to the implied warranties of merchantability and fitness for a particular purpose.

DreamLine™ will, at its election, repair, replace with product of equal value or make appropriate adjustment where DreamLine's analysis or inspection of warranty claim discloses any such defects occurring in normal usage within the warranty period. DreamLine warranty obligation shall be discharged upon tender of replacement or repair. Purchaser's refusal to accept the tender terminates warranty obligation.

Cost of freight for returning products to DreamLine™ for repairs or replacement under this limited warranty are the responsibility of the customer. Cost of freight associated with shipping of replacement product or parts to the customer may be charged to customer. Any product replaced or repaired during the warranty period will be covered only for the remaining period of the original warranty. In no event will DreamLine be liable for costs of repair or replacement of any installation material, including but not limited to tiles, marble, etc. **DreamLine™ is not responsible for installation, removal or reinstallation costs of any product requiring warranty services.**

Improper modification or alterations of any DreamLine™ products will void the warranty. Any DreamLine products repairs must be performed by either a DreamLine authorized agent or a licensed experienced professional contractor. This warranty shall not apply to breakage or damages caused by normal wear and tear, fault, carelessness, abuse, misuse, misapplication, improper maintenance, alteration or modification of the unit, as well as chemical or natural corrosion, accident, fire, flood, act of God or any other casualty. Improper care and cleaning will void the warranty. Never use cleaners containing abrasive cleansers, ammonia, bleach, acids, waxes, alcohol, solvents or other products not recommended for chrome or similar finish, glass or acrylic. This will void the warranty. For additional product maintenance instructions please refer to product installation manuals. The warranty does not extend to any non-DreamLine™ plumbing or components installed by installers, end users or by any party other than DreamLine™.

THE FOREGOING WARRANTIES ARE IN LIEU OF ALL OTHER WARRANTIES, EXPRESSED OR IMPLIED, INCLUDING BUT NOT LIMITED TO THE IMPLIED WARRANTIES OF MERCHANTABILITY AND FITNESS FOR A PARTICULAR PURPOSE. BATH AUTHORITY LLC ("DREAMLINE") AND/OR SELLER DISCLAIM ALL LIABILITY FOR SPECIAL, INCIDENTAL OR CONSEQUENTIAL DAMAGES. DREAMLINE™ IS NOT LIABLE FOR PERSONAL INJURIES OR DEATH TO ANY PERSON OR FOR ANY DIRECT, SPECIAL, INCIDENTAL OR CONSEQUENTIAL DAMAGE, LOSS OF USE, LOSS OF TIME, LOSS OF PROFITS, INCONVENIENCE, INCIDENTAL EXPENSES, LABOR OR MATERIAL CHARGES, OR ANY OTHER COSTS RESULTING FROM THE USE OF ITS PRODUCTS OR PERTAINING TO THE APPLICATION OF THE PRESENT WARRANTY, OR RESULTING FROM THE REMOVAL OR REPLACEMENT OF ANY PRODUCT OR ELEMENT OR PART COVERED BY THIS WARRANTY.

DreamLine™ is not responsible for product code compliance or for verifying code restrictions on installation or use and any such compliance is excluded from this warranty. DreamLine™ reserves the right to modify this warranty at any time - such warranty modification will not alter warranty applicable at the time of sale of the products in question. The warranty terms for specific products are:

SHOWER DOORS, SHOWER ENCLOSURES AND SHOWER BASES

DreamLine™ warrants shower doors, shower enclosures and shower bases to be free from defects in workmanship and materials under normal residential use for a period of five (5) years from the initial date of purchase by the owner/end-user, contractor or builder from an authorized dealer.

SHOWER CABINS (JETTED & STEAM)

DreamLine™ warrants glass, acrylic and finish to be free from defects in workmanship for a period of five (5) years from initial date of purchase by the owner/end-user, contractor or builder from an authorized dealer; and plumbing, electrical and steam generator components for a period of one (1) year from the initial date of purchase by the owner/end-user, contractor or builder from an authorized dealer.

SHOWER COLUMNS

DreamLine™ warrants shower columns to be free from defects in workmanship and materials under normal residential use for a period of one (1) year from the initial date of purchase by the owner/end-user, contractor or builder from an authorized dealer.

VANITIES AND VESSEL SINKS

DreamLine™ warrants bathroom vanities and vessel sinks to be free from defects in workmanship and materials under normal residential use for a period of one (1) year from the initial date of purchase by the owner/end-user, contractor or builder from an authorized dealer.

Some states/provinces do not allow limitations on how long an implied warranty lasts, or the exclusion or limitation of special, incidental or consequential damages, so these limitations and exclusions may not apply to you. This warranty gives you specific legal rights. You may also have other rights, which vary from state/province to state/province.



TEL: 866-731-8378 – 215-957-1411

FAX: 866-227-9245 – 215-893-1780

WWW.BATHAUTHORITY.COM

For more information on [DreamLine™ Tub Door](http://www.BathAuthority.com) please visit www.BathAuthority.com