



ENIGMA

SHOWER DOOR INSTALLATION INSTRUCTIONS

IMPORTANT

DreamLine™ reserves the right to alter, modify or redesign products at any time without prior notice. For the latest up-to-date technical drawings, manuals or any other details please refer to the support.BathAuthority.com web page.

60" wide

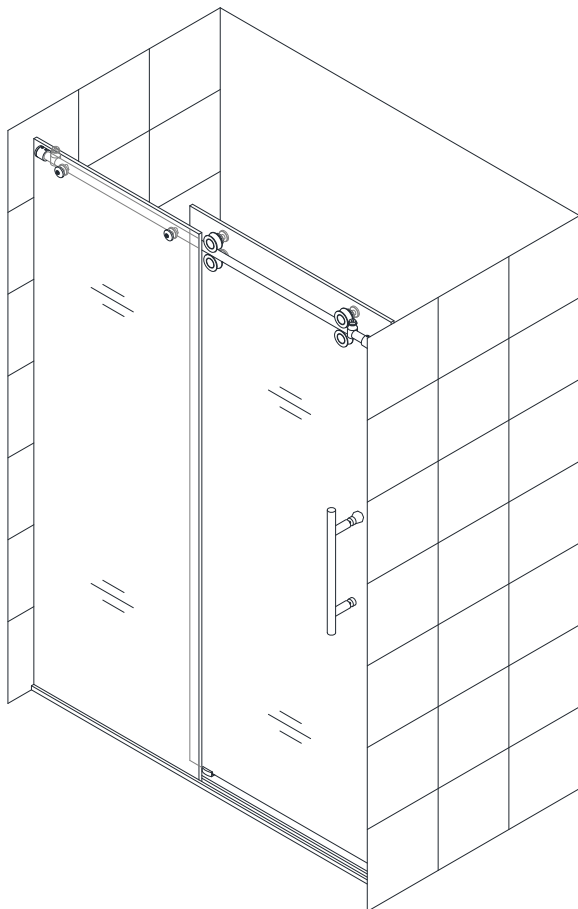

72" wide

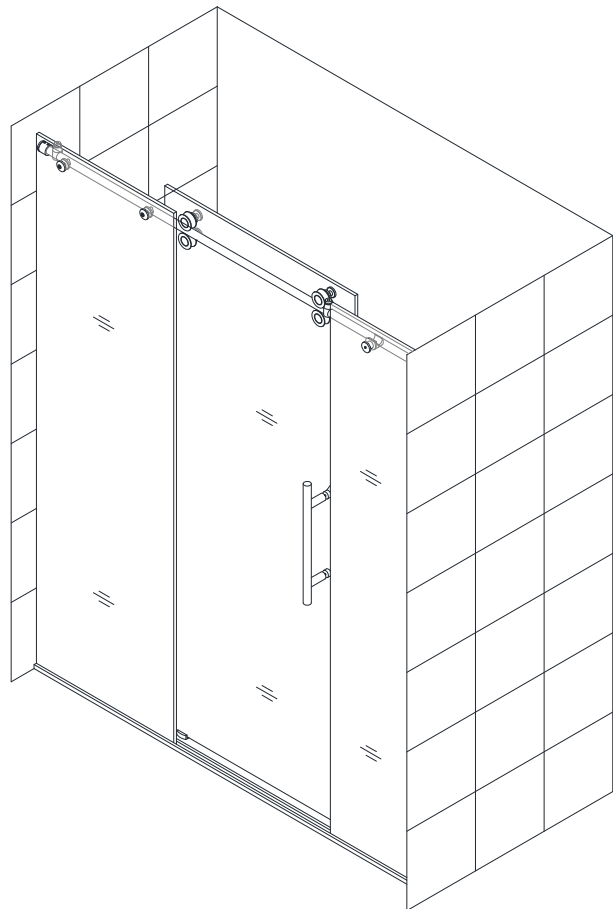

Please read these instructions carefully before installing. If you have any questions regarding installation, please call our technical support specialists Monday through Friday 9:00 AM – 5:00 PM EST at Phone: [1-866-731-2244](tel:1-866-731-2244), Fax: [1-866-227-1533](tel:1-866-227-1533) or e-mail our technical support group at support@BathAuthority.com.

For more information on [DreamLine™ Shower Door](http://www.BathAuthority.com) please visit www.BathAuthority.com

Preparation

1. After opening all boxes and packages, read this introduction carefully. Check that all of the needed parts are included in the package by marking all the components on the "Detailed Diagram of Shower Door Components". Examine boxes and packages for shipping damage. If the unit has been damaged, has a finishing defect, or has missing parts, please contact our customer support department within 5 business days of the delivery date. Please note that **DreamLine™ will not replace any damaged products or missing parts free of charge after 5 business days or if the product has been installed.** Feel free to contact DreamLine™ if you have any questions.
2. **Please note that you should consult your local building codes with questions on installation compliance standards. Building and plumbing codes may vary by location, and DreamLine™ is not responsible for code compliance standards for your project and will not accept any returns.**
3. Please ensure that prior to the installation the installation surface is leveled and solid and will be able to support the total weight of the unit. Also make sure the walls are at right angles. Irregular installation surface level or improper angle of side walls will result in serious problems for your installation. Please, note that some adjustments and drilling might be necessary during the installation process.
4. This unit has to be installed against a finished floor and walls.
5. **Please, NOTE! This door does not have out-of-plumb adjustment. Make sure your walls are at right angles.**
6. **This door requires 3^{1/2}" wide threshold or installation space.**
7. **Please note that Step #8 calls for installation of the door to the wall using anchors. However, the manufacturer strongly recommends installing these heavy doors to the studs or to preinstalled 2x6 wood reinforcements behind the wall and attaching the Wall brackets to it.**
8. a) If the width of your door is **60"** and less, you only need to refer to **(Diagram A)** with **(Packing List A)**.
b) If the width of your door is **72"** and less, and you are installing the door with the small stationary glass, you have to use **(Diagram A and B)** with **(Packing List A and B)** to complete the installation

Attention: This door is extremely heavy and requires professional installation.

Tools Required

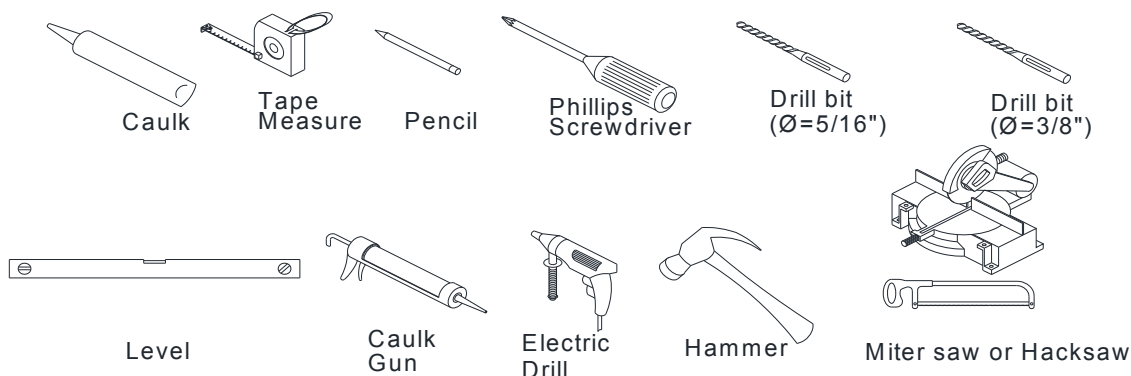

Detailed Diagram of the Shower Door Components

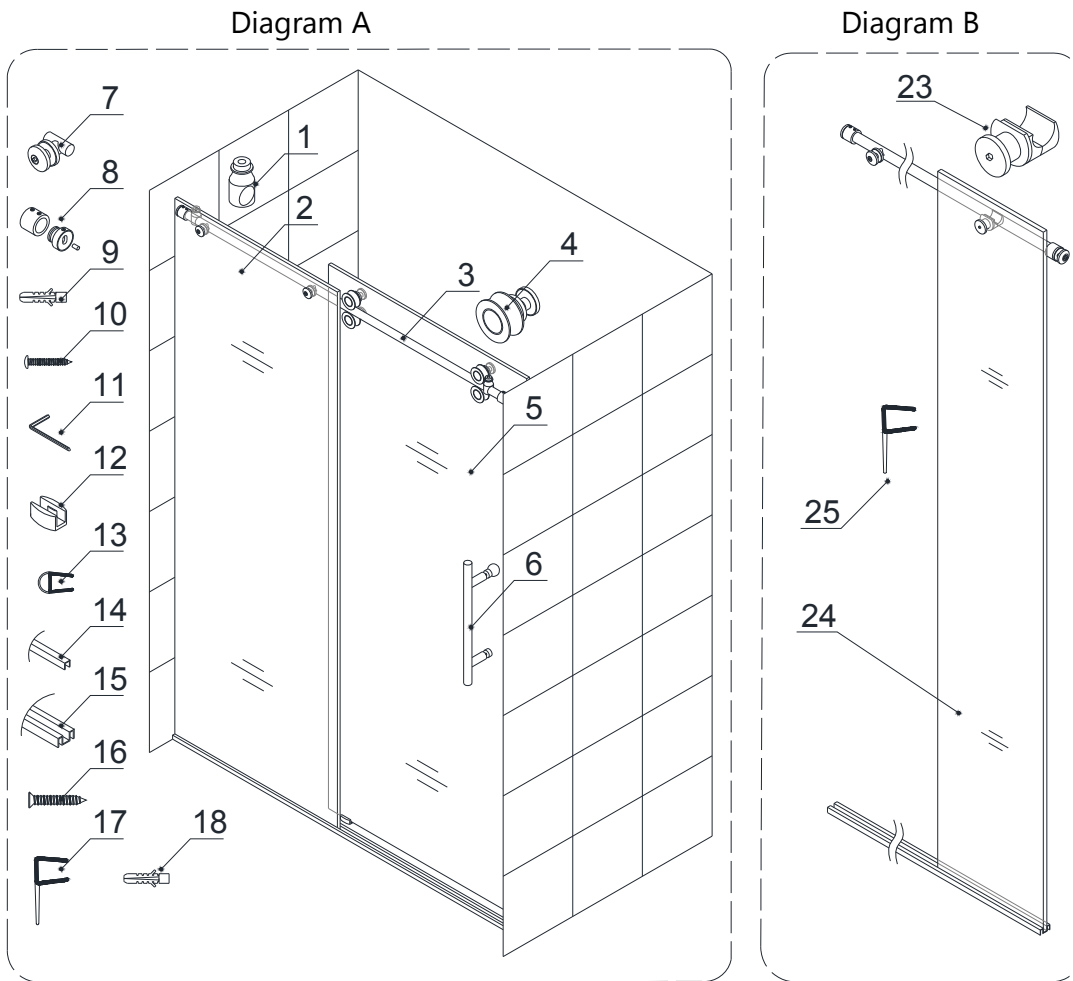

Packing List A

01	Door Stopper	2pcs	10	Round head screw ST6×45	2pcs
02	Stationary glass	1pc	11	Hex wrench 3mm, 4mm, 5mm	1set
03	Upper guide rail	1pc	12	Guide block	1pc
04	Roller	4pcs	13	Bumper strip	1pc
05	Glass door	1pc	14	Threshold cover	1pc
06	Handle	1pc	15	Threshold	1pc
07	Glass bracket	2pcs	16	Countersunk screw ST4.2×30	4pcs
08	Guide rail bracket	2pcs	17	Anti-water strip	2pcs
09	Wall anchor Ø 3/8"	2pcs	18	Small anchor Ø 5/16"	4pcs

Packing List B

23	Small stationary glass bracket	1pc	24	Small stationary glass	1pc
25	Anti-water strip	1pc			

NOTE: Unpack your unit carefully and inspect it. Lay it out and identify all parts using parts diagram and part list in your manual as a reference. Before discarding the carton, check for small hardware bags that tend to fall to the bottom of the box. If any parts are damaged or missing, please contact DreamLine™ for replacement.

NOTE: Retain these installation instructions for future reference.

Shower Door Installation

1. Measure the distance between two finished walls.
This distance is marked as "**W**".

See Fig. 1 for details.

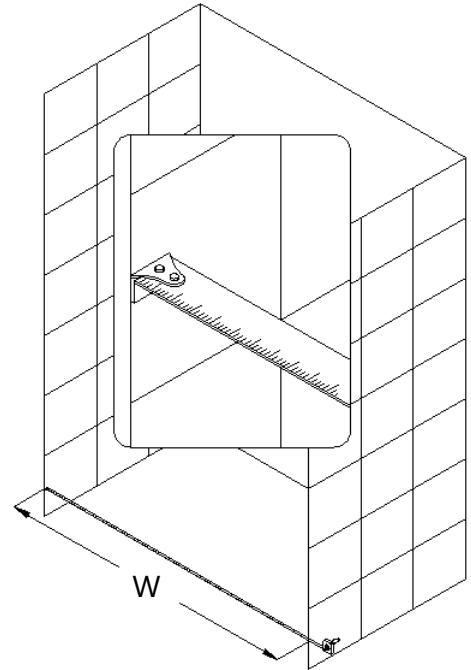

Fig. 1

2. Your **Upper Guide rail (03)** has been precut for your Shower model opening width: **60"** or **72"** for shower width.

If **W**-width of your wall-to-wall opening is equal to the size of your Shower model, it is unnecessary to cut the **Upper Guide rail** and you can continue to Step 4.

If **W**-width of your wall-to-wall opening is less than the size of your Shower model, you will need to cut the **Upper Guide rail** from the end which is farther from the **Glass brackets (07)** holes.

The length to cut off will be **L**:

L=Subtract **W** from the size of your Shower model.

FOR EXAMPLE

If your wall opening **W=59"**. Your shower model is **60"**.

L=60"-59"=1",

You have to cut **1"** off from the rail.

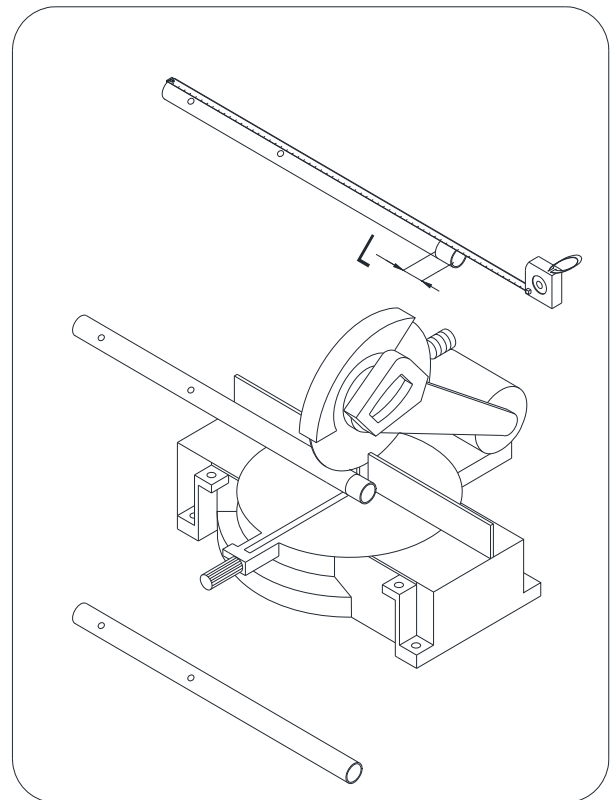

Fig. 2

See Fig. 2 for details.

3. Your **Threshold (15)** has been precut for your Shower model opening width: **60"** or **72"** for shower width.

If **W**-width of your wall-to-wall opening is equal to the size of your Shower model, it is unnecessary to cut the **Threshold** and you can continue to Step 4.

If **W**-width of your wall-to-wall opening is less than the size of your Shower model, you will need to cut the **Threshold** to the size of "**W**".

See Fig. 3 for details.

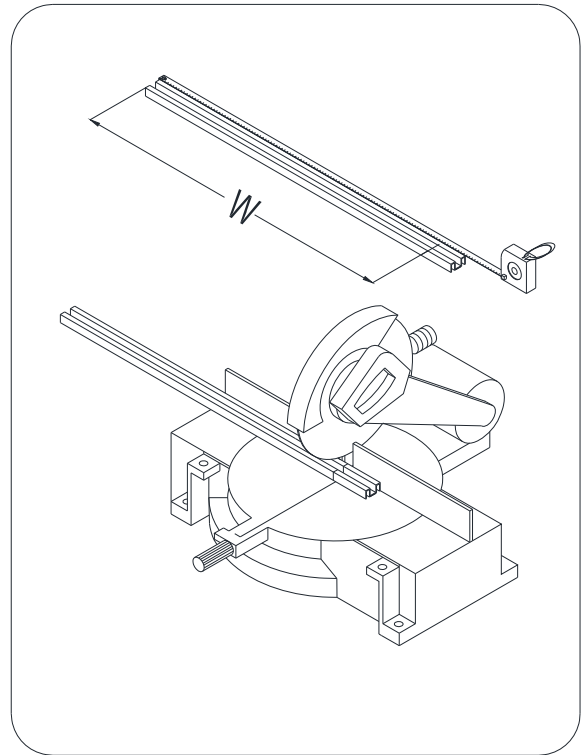

Fig. 3

4. Place the **Threshold (15)** into the designated position parallel to the back wall.

See Fig. 4 for details.

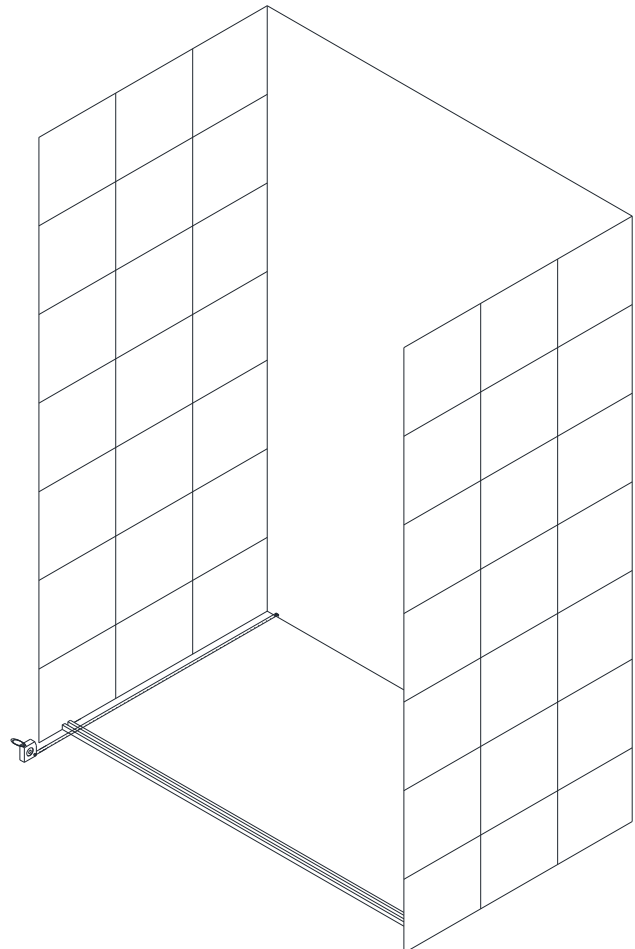

Fig. 4

5. Mark the drilling holes on the floor through predrilled holes in the **Threshold (15)**.

Remove the **Threshold**, drill the holes in the floor using $\text{Ø } 5/16''$ drill bit and insert the **Small anchors Ø5/16'' (18)**.

Apply silicone on the bottom of the **Threshold** along the center line and around the holes, place it back to the designated position and fasten it to the floor with the **Countersunk screws ST4.2×30 (16)**.

See Fig. 5 for details.

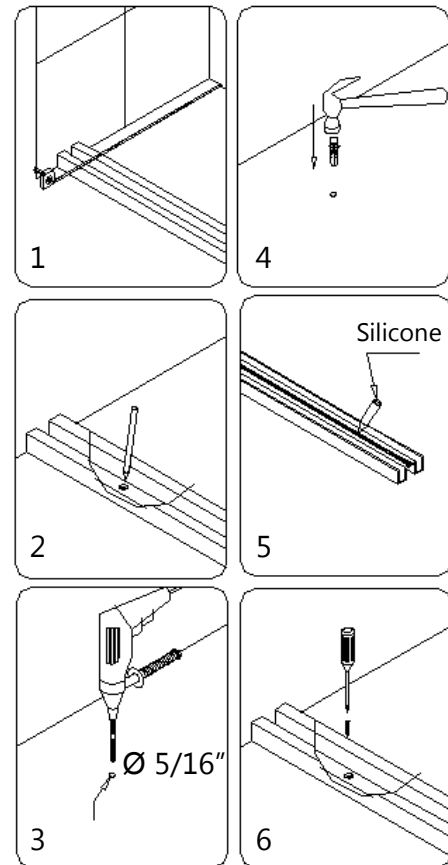

Fig. 5

6. Install the **Upper guide rail (03)** onto the **Stationary glass (02)** with the **Glass brackets (07)** and tighten the set screws.

Slide the **Door stoppers (01)** on each end of the **Upper guide rail** and secure them temporarily.

Slide the **Guide Rail brackets (08)** on each end of the **Guide rail** and temporarily secure them as well.

See Fig. 6 and Fig. 7 for details.

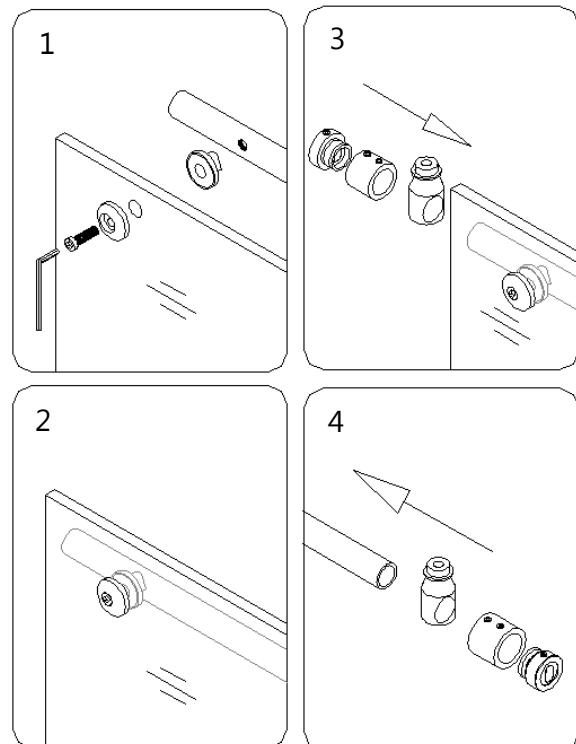

Fig. 6

If the width of your door is **72"** and you are installing the door with the **Small Stationary glass (24)**, attach **Small Stationary glass bracket (23)** to the **Upper guide rail (03)** as shown in Fig. 7(B)

NOTE:

Before you install the **Stationary glass (02)**, you have to take the **Glass door (05)** into the shower room and lean it against the wall.

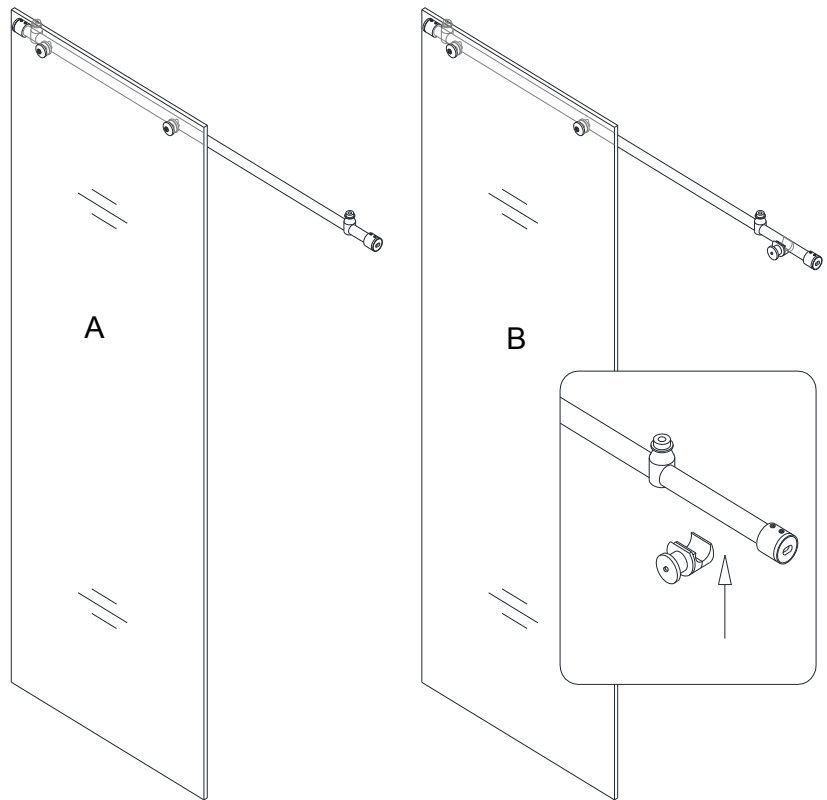

Fig. 7

7. Place the **Stationary glass (02)** into the groove of the **Threshold (15)** and butt it up against the wall.

(Please note that the Upper guide rail (03) secured on the Stationary Glass must face inside the shower).

Make sure the **Stationary glass** and the **Upper guide rail** are leveled. If a horizontal adjustment is required, adjust it in the **Glass brackets (07)**.

See Fig. 8 for details.

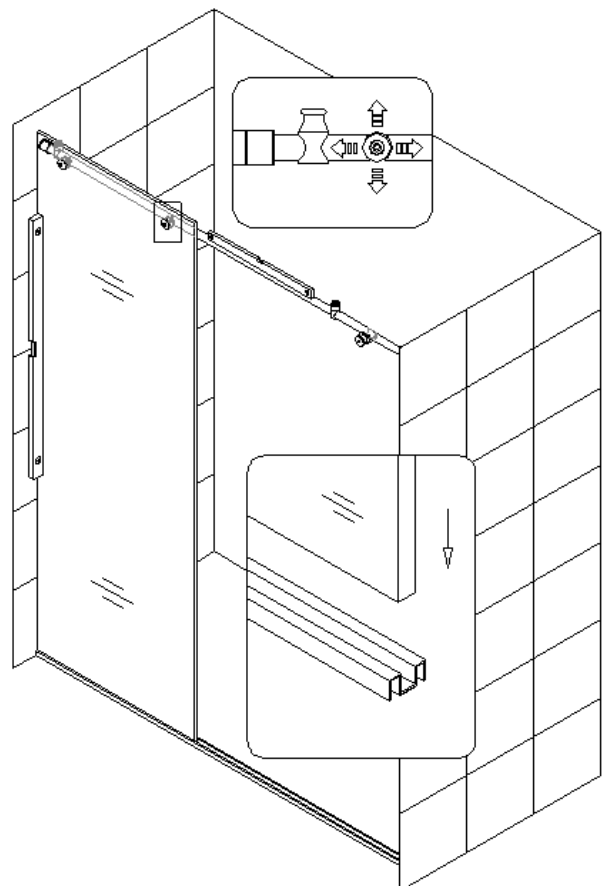

Fig. 8

8. Outline the **Guide rail brackets (08)** position on the wall.

Put the **Stationary glass (02)** aside.

Remove the **Guide rail brackets** from the **Upper guide rail (03)**, place the male part of the **Upper guide rail (03)** to the outlined positions on the wall and mark the drilling holes. Drill the holes using $\text{Ø } 3/8''$ drill bit.

Insert the **Wall anchors $\text{Ø}3/8''$ (9)** and mount the male part of the **Guide rail brackets** onto the wall using the **Round head screws $\text{ST6}\times 45$ (10)**.

See fig. 9 for details.

NOTICE:

Manufacturer strongly recommends installing these heavy doors to the studs or to preinstalled 2x6 wood reinforcements behind the wall and attaching the Wall brackets to it.

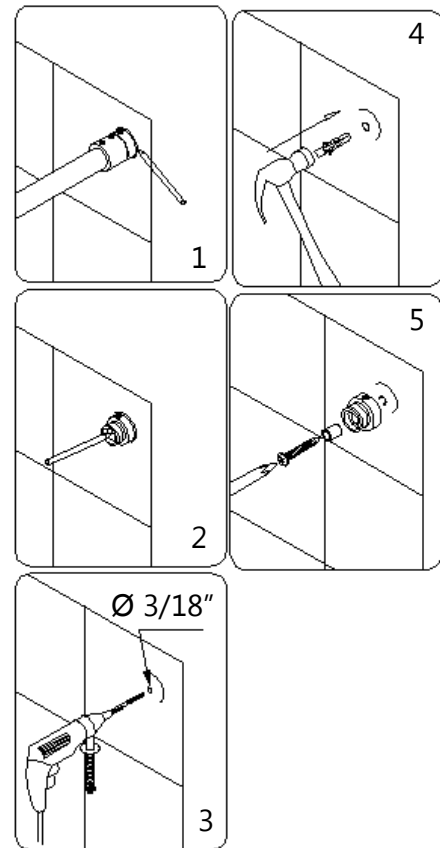

Fig. 9

9. Apply a small amount of waterproof silicone into the **Threshold (15)** channel.

Place the **Stationary glass (02)** back in position and attach both female parts of the **Guide rail brackets (08)** to their male parts on the walls.

Tighten the set screws on the **Guide rail brackets** to secure the **Upper guide rail (03)** between two walls.

Upper guide rail (03) must be leveled horizontally. Adjust **Guide rail bracket (08)** using hex key on both ends if it necessary to level the **Upper guide rail**. Tighten the screws from top and bottom of the **Guide rail bracket**.

See Fig. 10 and Fig. 11 for details.

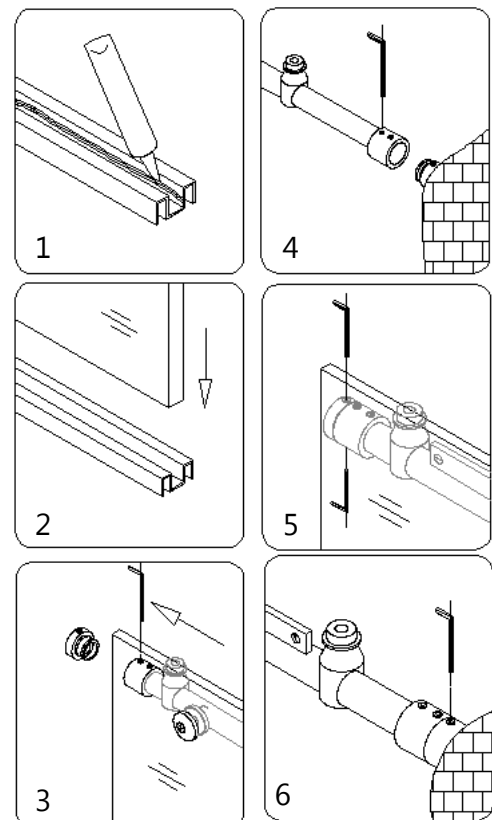

Fig. 10

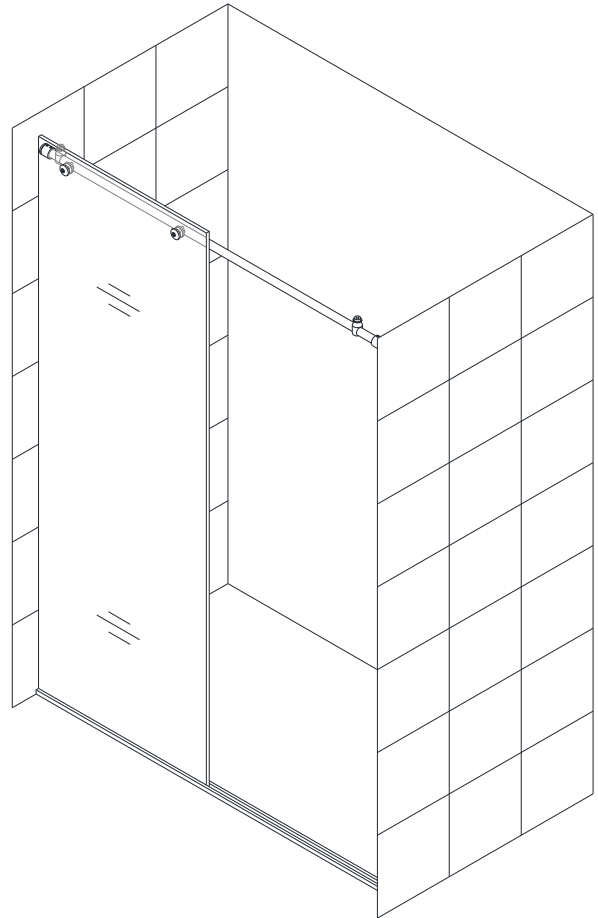

Fig. 11

ATTENTION:

This Step shows **Small Stationary Glass (24)** installation for **72"** door only.

10. Screw off the female part from the **Small stationary glass bracket (23)**. Apply a small amount of silicone into the **Threshold (15)** channel. Slide the **Small stationary glass (24)** into the groove of the **Threshold** and butt it up against the wall. Secure the **Small stationary glass** to the **Small stationary glass bracket**, and fasten the female part of the bracket back to its male part.

See Fig. 12 and Fig. 13 for details.

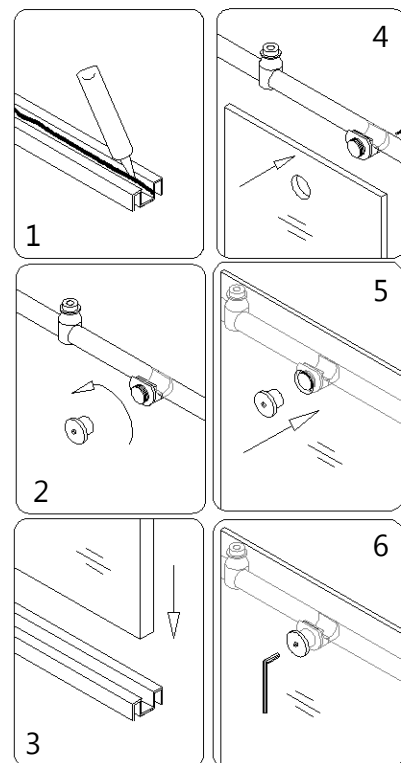

Fig. 12

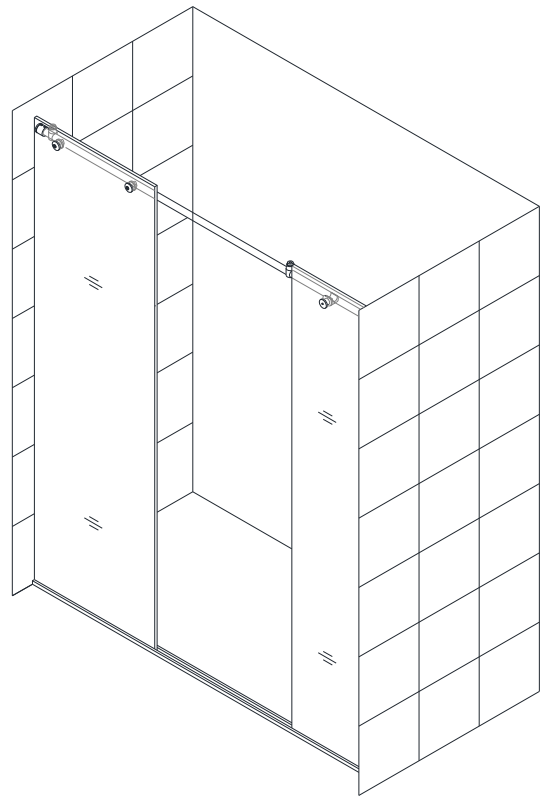

Fig. 13

11. A. Measure the distance between the **Stationary glass (02)** and the wall for **60"** door.
- B. Measure the distance between the **Stationary glass** and the **Small Stationary glass (24)** for **72"** door.

Cut the **Threshold cover (14)** to the size of your measurement.
 Apply a small amount of silicone into the **Threshold (15)** channel and push the **Threshold cover** into the **Threshold (15)** channel.

See Fig. 14 for details.

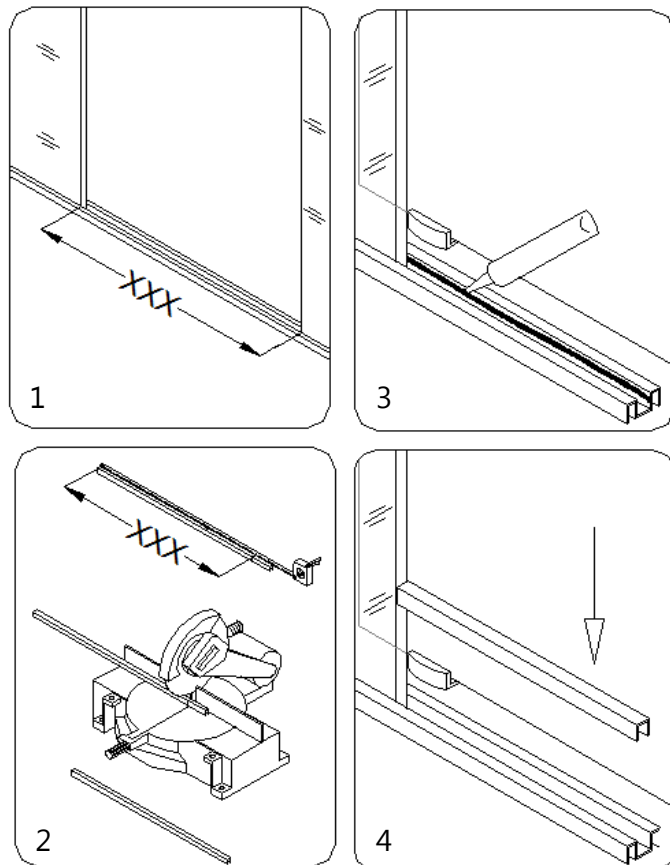

Fig. 14

12. Place the **Guide block (12)** on the floor and parallel it to the **Stationary glass (02)**. It should not pass beyond the vertical edge of the glass.

Take a measurement to ensure the distance between the front line of the glass and the center line of the **Guide block** is **2 3/16"**.

Hold it firmly and mark the drilling hole on the floor. Remove the **Guide block**, drill the hole in the floor using **Ø 5/16"** drill bit, insert the **Small anchor Ø5/16"** (18) in and then fasten the **Guide block** to the floor with the **Countersunk screw ST4.2×30 (16)**.

See Fig. 15 for details.

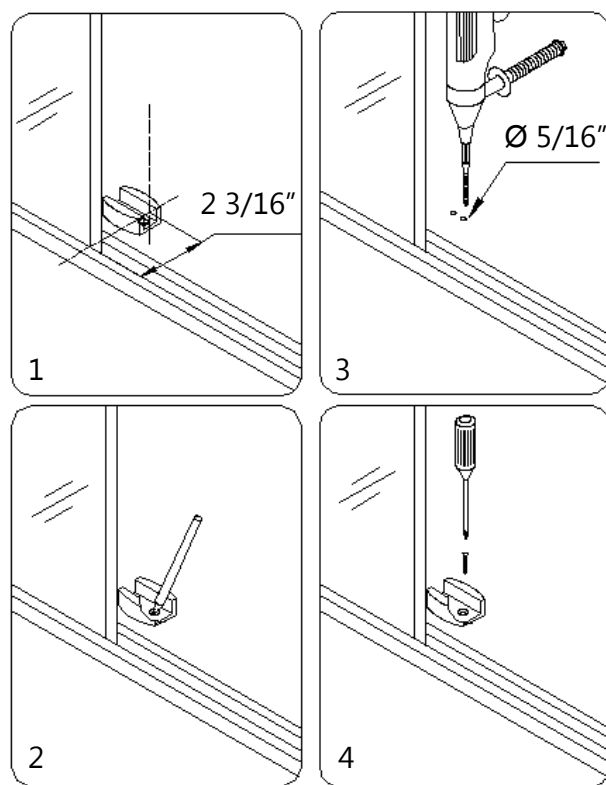

Fig. 15

13. Attach two top **Rollers (04)** to the **Glass door (05)**.

Suspend the door by hanging the **Rollers** onto the **Upper guide rail (03)** and slide the bottom edge of the **Glass door** into the groove of the **Guide block (12)**.

Then mount two lower **Rollers (04)** onto the **Glass door** to secure the **Glass door** to the **Upper guide rail**.

See Fig. 16 for details.

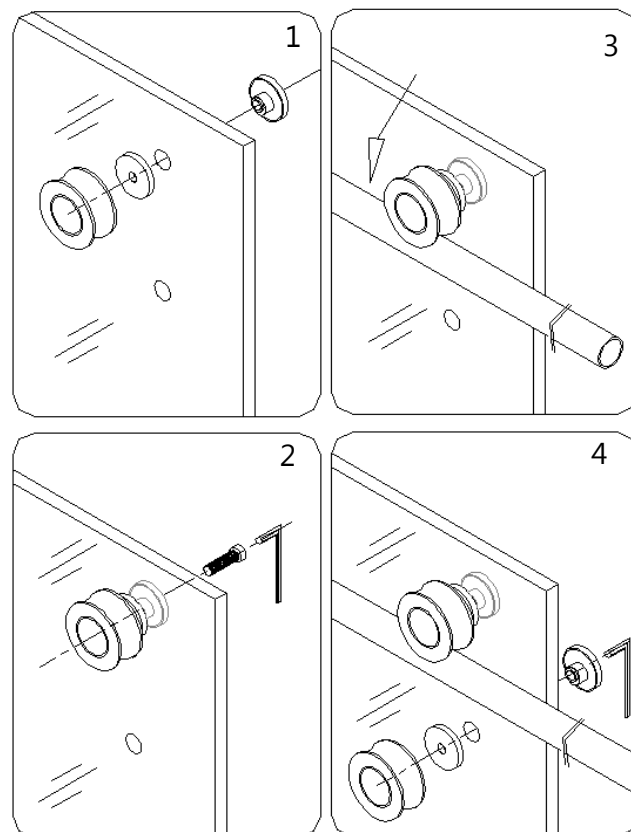

Fig. 16

14. Adjust the fasteners on both top **Rollers (04)** to ensure that the bottom edge of the **Glass door (05)** does not touch the bottom of the **Guide block (12)**. Tighten the fasteners.

See Fig. 17 for details.

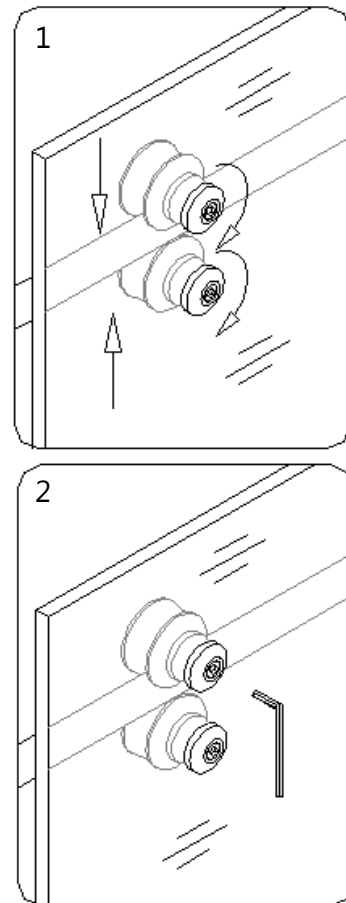

Fig. 17

15. Press the **Bumper strip (13)** on the vertical edge of the **Glass door (05)** and also press the **Anti-water strip (17)** on the vertical edges of the **Stationary glass (02)** and the **Glass door**.

See Fig. 18 (A) for details.

Press **Anti-water strip (25)** on the vertical edge of the **Small Stationary glass (24)** if width of your unit is **72"** as shown in Fig. 18 (B)

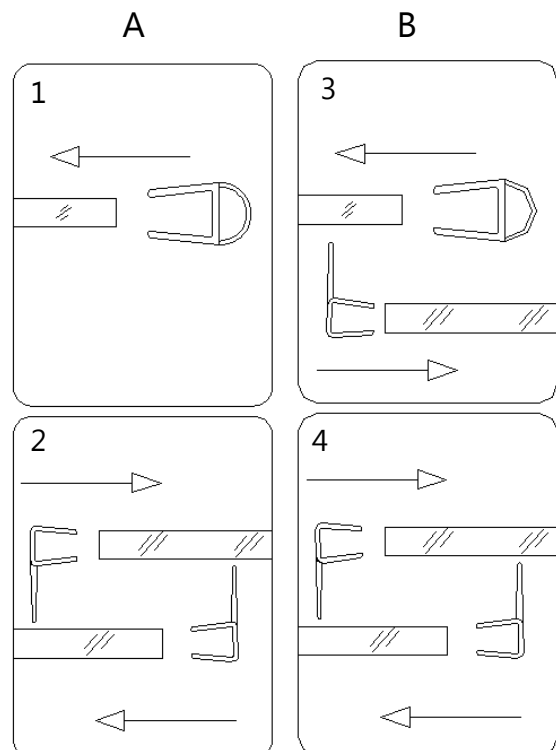

Fig. 18

16. Adjust both **Door Stoppers (01)** to ensure that they are positioned upright and the **Glass door (05)** is in its maximum opening and closing range. Tighten the set screws to fasten them in place.
Mount the **Handle (06)** to the **Glass door**.

See Fig. 19 for details.

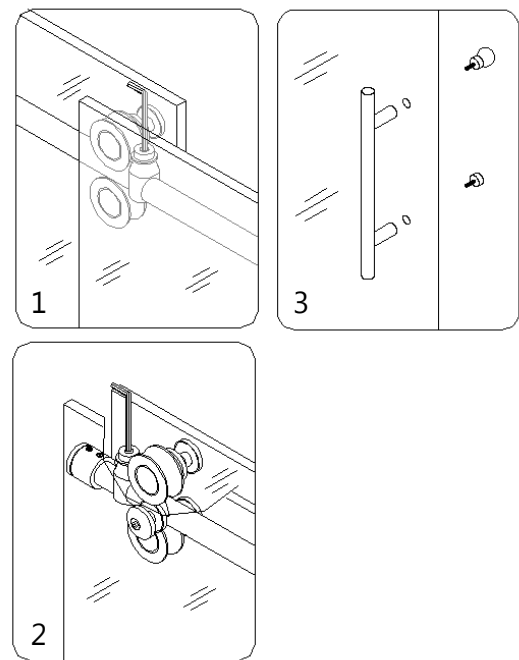

Fig. 19

17. Apply silicone along the connection of the **Stationary glasses** and the wall. You may also apply additional layer of silicone along the **Threshold** (optional).

See Fig. 20 for details.

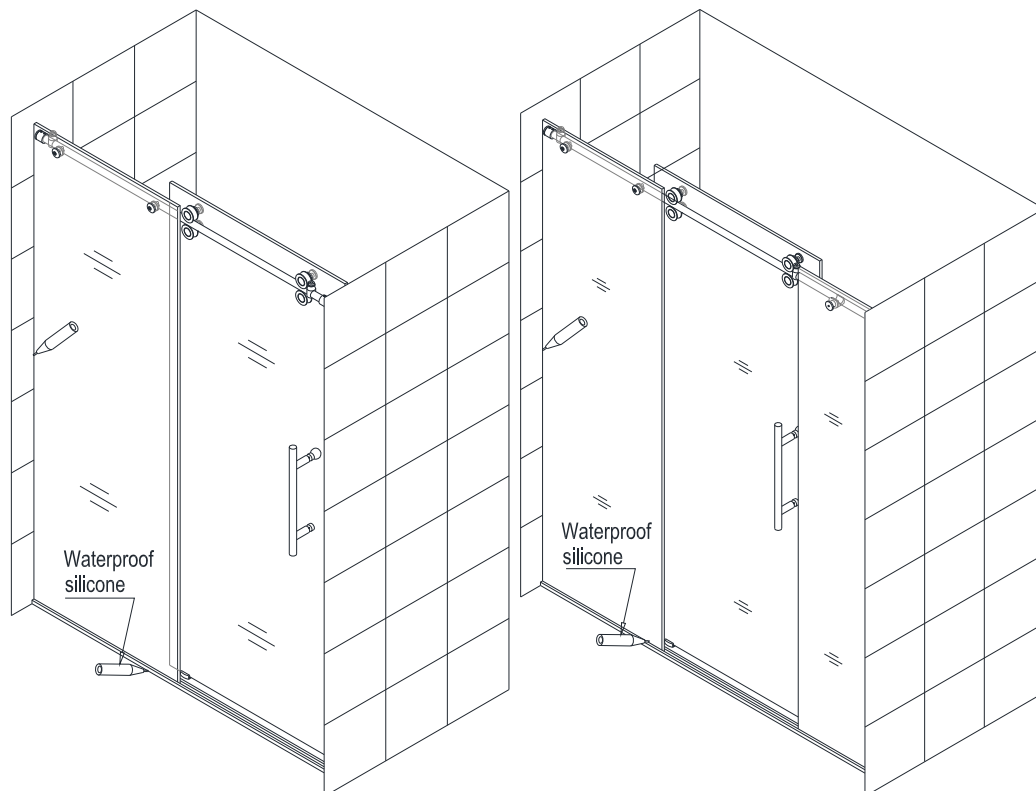

Fig. 20

Product Maintenance

To insure long lasting life for your acrylic back walls, wipe them off after each use with a soft cloth. To clean the acrylic back walls use non-abrasive sprays or cream based cleaners. Never use abrasive cleansers, metal brushes or scrapers that could scratch or dull the surface.

To insure long lasting life for your glass shower products, wipe them off after each use with a soft cloth. Rinse and wipe of the glass using either soft cloth or squeegee to prevent soap buildup. Never use abrasive cleaners and cleaning products that contain scoring agent because this may scratch the surface. Never use bristle brushes or abrasive sponges.

To assure a long lasting finish wipe off the metal parts after each use with a soft cloth. Do not use abrasive cleaners or cleaning products containing ammonia, bleach or acid. If accidentally used, rinse the surface as soon as possible to prevent finish peeling or corrosion. After cleaning the shiny finishes, rinse thoroughly and wipe dry with soft cloth. Clean stainless steel surfaces at least once a week. When applying stainless steel cleaner or polish, work with (not across) the grain. Never use abrasive sponge or cloth, steel wool or wired brushes.

DREAMLINE™ EXCLUSIVE LIMITED WARRANTY AS OF MAY 6, 2013

This warranty extends only to the original owner/end-user for household use only and is not transferable to a subsequent owner. This warranty extends for a designated period of time, so long as it remains in use in its original place of installation. This warranty applies only to DreamLine products purchased from an authorized dealer in United States or Canada. Proof of purchase (original sales receipt) from the original consumer purchase must be provided with all warranty claims.

IN NO EVENT SHALL THE LIABILITY OF DREAMLINE EXCEED THE PURCHASE PRICE OF THE UNIT.

DreamLine products must be installed by a fully insured and licensed professional. Installation of DreamLine product by anyone other than fully insured licensed professionals shall **VOID THE WARRANTY**. DreamLine recommends that such licensed professionals have experience in the installation of bathroom products. Installation of certain products, including, without limitation, glass products (i.e., shower and tub doors) by an inexperienced installer may result in glass breakage and, consequently, cause personal injury or death.

PARTS ONLY WARRANTY

This warranty is extensive in that it covers replacement of all defects. LABOR CHARGES AND/OR DAMAGE INCURRED IN INSTALLATION, REPAIR, OR REPLACEMENT, AS WELL AS ANY OTHER KIND OF LOSS OR DAMAGE ARE EXCLUDED

COMMERCIAL USE AND OTHER EXCLUSIONS

This warranty excludes all industrial, commercial and business usage, whose purchasers are hereby extended a one (1) year limited warranty from the date of purchase for shower and tub doors, a three (3) month limited warranty from the date of purchase for vanities and sinks, with all other terms of this warranty applying except the duration of the warranty.

DREAMLINE JETTED AND STEAM SHOWER CABINS, DREAMLINE SHOWER COLUMNS AND DREAMLINE SHOWER SEATS ARE NOT INTENDED FOR COMMERCIAL USE AND THERE IS NO WARRANTY EXTENDED FOR THESE PRODUCTS FOR COMMERCIAL USE.

DreamLine hereby disclaims all warranties for products sold as dealer or store displays. DreamLine hereby disclaims all warranties for products used outside of the United States or Canada whether expressed or implied, including but not limited to the implied warranties of merchantability and fitness for a particular purpose.

WARRANTY TERMS

DreamLine will, at its election, repair or replace the product found by DreamLine in its sole judgment, to be defective within the warranty period under normal residential use and maintenance. The replacement of a product is limited to supplying a replacement product or part (same as existing or if not available, comparable product). DreamLine warranty obligation shall be discharged upon tender of parts, replacement or repair of the product. Purchaser's refusal to accept the tender terminates all warranty obligations and **VOIDS THE WARRANTY**. Cost of freight for returning products to DreamLine for repairs or replacement under this limited warranty are the responsibility of the customer. Cost of freight associated with shipping of replacement product or parts to the customer may be charged to customer. Any product replaced or repaired during the warranty period will be covered only for the remaining period of the original warranty. In no event will DreamLine be liable for costs of repair or replacement of any installation material, including but not limited to tiles, marble, etc.

DREAMLINE IS NOT RESPONSIBLE FOR INSTALLATION, REMOVAL OR REINSTALLATION COSTS OF ANY PRODUCT REQUIRING WARRANTY SERVICES.

Any modification or alteration of any DreamLine products will void the warranty. DreamLine product installations and repairs must be performed by either a DreamLine authorized agent or a licensed, insured and experienced professional contractor - installation or repairs performed by any other party shall void the warranty. This warranty shall not apply to breakage or damages caused by normal wear and tear, fault, carelessness, abuse, misuse, misapplication, improper maintenance, alteration or modification of the unit, as well as chemical or natural corrosion, accident, fire, flood, act of God or any other casualty. Improper care and cleaning will void the warranty. Use of cleaners containing abrasive cleansers, ammonia, bleach, acids, waxes, alcohol, solvents or other products not recommended for chrome or similar finish, glass or acrylic will void the warranty. For additional product maintenance instructions please refer to product installation manual. DreamLine is not responsible for any issues arising in connection with errors or omissions in information provided on DreamLine's websites. The warranty does not extend to any non-DreamLine plumbing or components installed by installers, end users or by any party other than DreamLine.

THE FOREGOING WARRANTIES ARE IN LIEU OF ALL OTHER WARRANTIES, EXPRESSED OR IMPLIED, INCLUDING BUT NOT LIMITED TO THE IMPLIED WARRANTIES OF MERCHANTABILITY AND FITNESS FOR A PARTICULAR PURPOSE. BATH AUTHORITY LLC ("DREAMLINE") AND/OR SELLER DISCLAIMS ALL LIABILITY FOR SPECIAL, INCIDENTAL OR CONSEQUENTIAL DAMAGES. DREAMLINE IS NOT LIABLE FOR PERSONAL INJURIES OR DEATH TO ANY PERSON OR FOR ANY DIRECT, SPECIAL, INCIDENTAL OR CONSEQUENTIAL DAMAGE, LOSS OF USE, LOSS OF TIME, LOSS OF PROFITS, INCONVENIENCE, INCIDENTAL EXPENSES, LABOR OR MATERIAL CHARGES, OR ANY OTHER COSTS RESULTING FROM THE USE OF ITS PRODUCTS OR PERTAINING TO THE APPLICATION OF THE PRESENT WARRANTY, OR RESULTING FROM THE REMOVAL OR REPLACEMENT OF ANY PRODUCT OR ELEMENT OR PART COVERED BY THIS WARRANTY.

PRODUCT WARRANTY PERIODS

DreamLine is not responsible for product code compliance or for verifying building code restrictions on installation or use and any such compliance is excluded from this warranty. DreamLine reserves the right to modify this warranty at any time - such warranty modifications will not alter the warranty applicable at the time of sale of the products in question. The warranty terms for specific products for consumer (non-industrial, non-commercial, non-business use only) are:

SHOWER BACKWALL, SHOWER CABINS (JETTED & STEAM)

DreamLine warrants shower backwalls and shower cabins to be free from defects in workmanship for a period of one (1) year from initial date of purchase by the owner/end-user, contractor or builder from an authorized dealer.

SHOWER & TUB DOORS, SHOWER ENCLOSURES

DreamLine warrants shower doors, tub doors and shower enclosures to be free from defects in workmanship and materials under normal residential use for a period of five (5) years from the initial date of purchase by the owner/end-user, contractor or builder from an authorized dealer. Warranty for plastic strips shall be limited to one (1) year. Warranty for any part in Oil Rubbed Bronze finish shall be limited to one (1) year.

SHOWER BASES

DreamLine warrants shower bases to be free from defects in workmanship and materials under normal residential use for as long as the original consumer purchaser owns their home in which their product is installed.

SHOWER COLUMNS

DreamLine warrants shower columns to be free from defects in workmanship and materials under normal residential use for a period of one (1) year from the initial date of purchase by the owner/end-user, contractor or builder from an authorized dealer.

SHOWER SEATS

DreamLine warrants shower seats to be free from defects in workmanship and materials under normal residential use for a period of one (1) year from the initial date of purchase by the owner/end-user, contractor or builder from an authorized dealer. Warranty shall be VOID if the shower seat is not professionally installed on a properly reinforced wall.

VANITIES AND VESSEL SINKS

DreamLine warrants bathroom vanities and vessel sinks to be free from defects in workmanship and materials under normal residential use for a period of one (1) year from the initial date of purchase by the owner/end-user, contractor or builder from an authorized dealer.

STATE LAWS AND THIS WARRANTY

Some states/provinces do not allow limitations on how long an implied warranty lasts, or the exclusion or limitation of special, incidental or consequential damages, so these limitations and exclusions may not apply to you. This warranty gives you specific legal rights. You may also have other rights, which vary from state/province to state/province.

WARRANTY SERVICE

The following information will be required for you to file a Warranty claim:

1. Your name, address and telephone number
2. Product model number
3. Brief description of problem (please note that additional information such as photos may be required to fully process your warranty claim)
4. Proof of purchase

You may submit this information by e-mail, mail or fax to:

DreamLine
Warranty Service Center
75 Hawk Road
Warminster, PA 18974
F:1-866-857-3638
T:1-866-731-2244
Warranty@bathauthority.com



TEL: [866-731-2244](tel:866-731-2244)

FAX: [866-227-1533](tel:866-227-1533)

WWW.BATHAUTHORITY.COM

For more information on [DreamLine™ Shower Door](http://www.BathAuthority.com) please visit www.BathAuthority.com