

**NEW
PRODUCT**

CG-1 & CG-2 Mini-Groover Walk Behind Machines

From:



**CG-1 Uses 12" Blades
on a 5" Bladeshift**

Specifications made to fit your application



CG-2 unit
not shown

CG-1
Weight: 800 lbs.

**Affordable and Compact Grinding, Grooving
and Texturing Machine**

CG-1 & CG-2 Features:

- **CG-1 - 10" wide grinding head capacity**
- **CG-2 - 16" wide grinding head capacity**
- **Available with various power choices**
- **Hydrostatic transmission**
- **Maneuverable in hard to reach areas**
- **Power raise/lower system**

Useful for Creating Textured Anti-Slip Areas for Improved Traction

Model #	Description	Part #	Cat #
CG-1G24	20.5 Honda GX670, 10" Grinding Head	5803003	08005
CG-1GE15	15HP Electric, 10" Grinding Head	5803005	08009
CG-2D49	49HP Deutz Diesel, 16" Grinding Head	5803006	08771
CG-2E30	30HP Lincoln Electric, 16" Grinding Head	5803007	08985

Diagram #	CG-1 Dimensions	CG-2 Dimensions
A	38.875"	49.375"
B	42"	65.75"
C	88"	120.5"
D	18"	38"
E	24.375"	26.75"
F	27"	64.25"
G	38"	34"
H	27"	13.5"
I	22"	29.375"
J	22"	21.28"

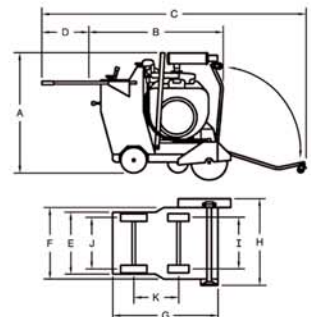

333 Prospect Street - Elyria, Ohio 44035
Local: 440-323-4616 Fax: 800-634-4035

