



LED BLACK OUTDOOR WALL LIGHT ASSEMBLY/INSTALLATION INSTRUCTIONS

Item # 589564: OAK CREEK DOWNLGT WALL LIGHT DUSK TO DAWN

Please read carefully and save these instructions, as you may need them at a later date.

CAUTION

WARNING: Risk of Fire. Min 90°C supply conductors. Consult a qualified electrician to ensure correct branch circuit conductor.

Turn off the main power at the circuit breaker before installing the fixture, in order to prevent possible shock.

GENERAL

All electrical connections must be in accordance with local and National Electrical Code (N.E.C.) standards. If you are unfamiliar with proper electrical wiring connections obtain the services of a qualified electrician.

Remove the fixture and the mounting package from the box and make sure that no parts are missing by referencing the illustrations on the installation instructions.

ASSEMBLY AND INSTALLATION

Turn off the power at fuse or circuit breaker.

1. Gently take all parts out of the package and lay them on a smooth surface. Remove screws from top of back plate and remove mounting plate. Attach the mounting plate to the Junction box using two junction box screw.
2. Install the decoration on the lamp body..
3. Make wire connections with wire connectors:
 - A- Connect the black wire from the fixture to the black supply wires.
 - B- Connect the white wire from the fixture to the white supply wires.
 - C- Attach the fixture ground wire to the mounting plate with the green ground screw. Connect it to the supply ground wire with the wire connector. Carefully tuck wires back into The junction box .
4. Pass the rivet below the fixture through the two holes below the mounting plate, and install it to the mounting plate through the screw hole above the fixture using the mounting screws. Wet-position lamps are constructed to prevent water accumulation on live parts, electrical parts, or conductors that are not intended to come into contact with water.
5. Install light bulb.

Turn on the power at fuse or circuit breaker

NOTE: After securing fixture to the wall it is recommended that the gap between the wall and the fixture backplate be sealed on the top and both sides, with a good quality waterproof caulk or silicone sealant (not included).

ASSEMBLY AND INSTALLATION (CONT.)

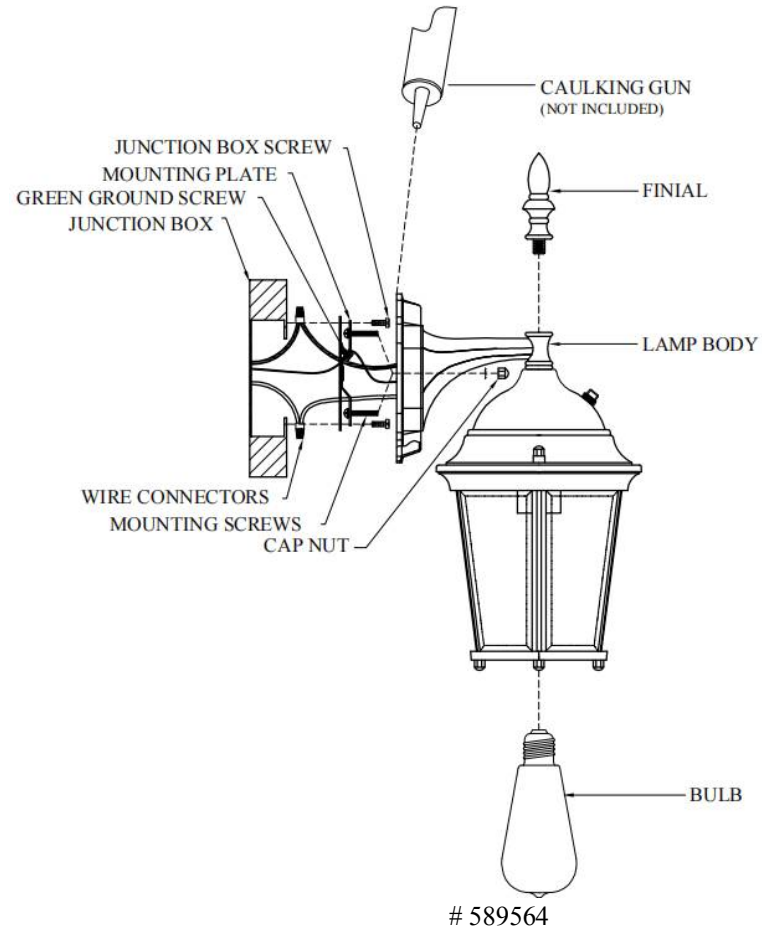

**IF IN DOUBT ABOUT ELECTRICAL INSTALLATION,
CONSULT A LICENSED ELECTRICIAN.**

Customer Service 1-800-558-8700