

75305

Submitted Model No.: \_\_\_\_\_

Specific Features: \_\_\_\_\_

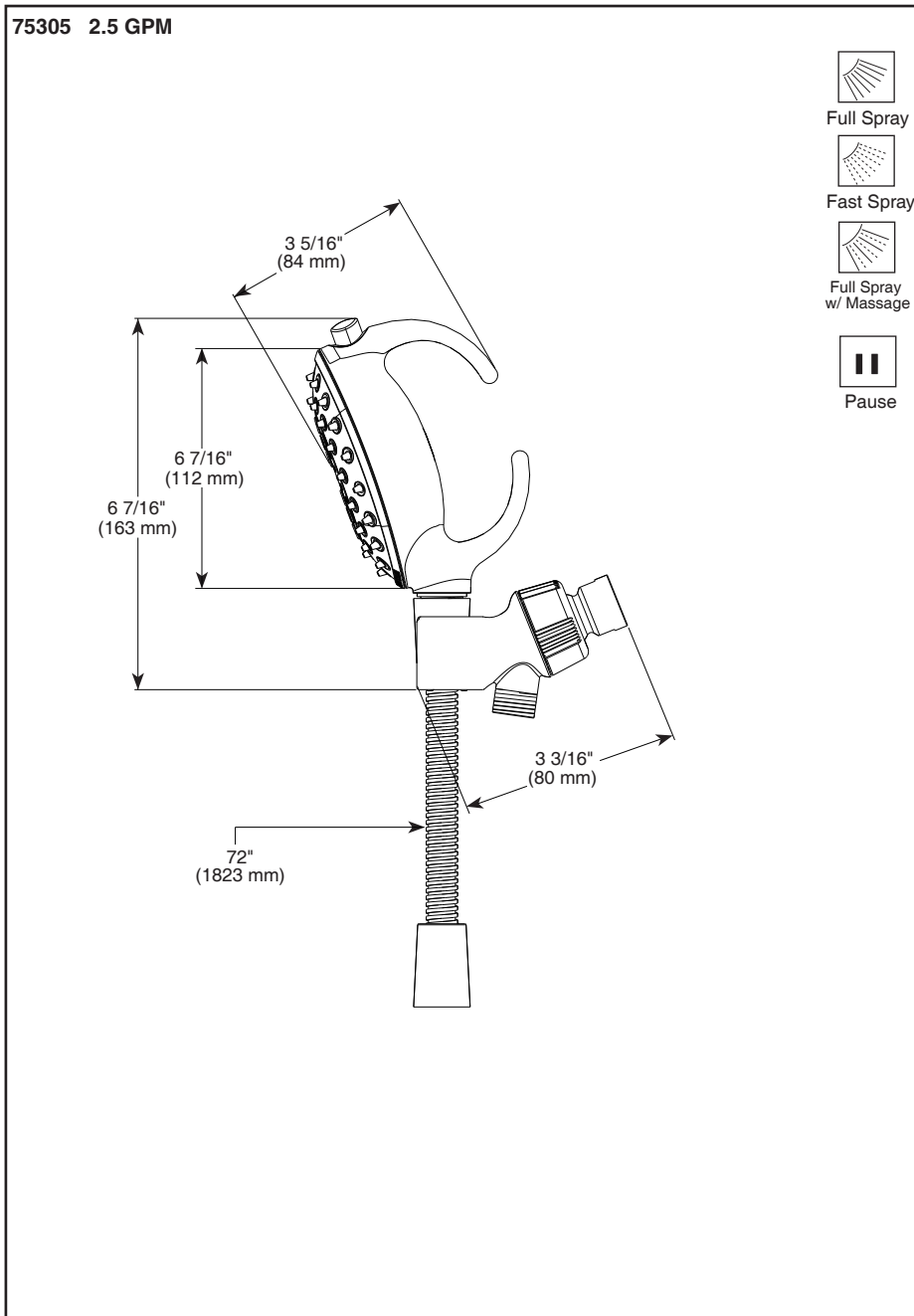

# HANDSHOWER

- 4-Spray settings handshower
- Palm® shower
- Touch-Clean® nozzles
- Push button selection

## STANDARD SPECIFICATIONS:

- Fixed showerhead and palm shower all in one.
- Change spray modes with push button.
- Soft touch handle.
- Adjustable shower arm mount allows for hands-free showering
- 72" (1823mm) stainless steel hose.
- Maximum water consumption 2.5 gpm (9.5 L/min) @ 80 psi.

## WARRANTY

- Lifetime limited warranty on parts (other than electronic parts and batteries) and finishes; or for commercial users, for 5 years from the date of purchase.
- 5 year limited warranty on electronic parts (other than batteries); or for commercial users, for 1 year from the date of purchase. No warranty is provided on batteries.



## COMPLIES WITH

- ASME A112.18.1/CSA B125.1

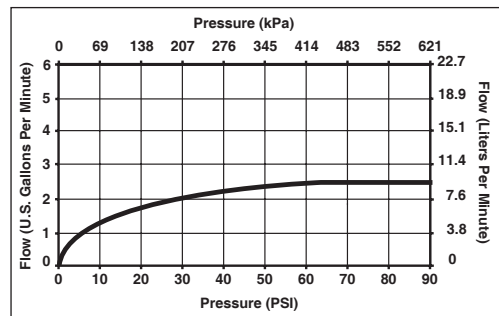

55 E. 111th Street, Indianapolis, Indiana 46280  
 350 South Edgeware Road, St. Thomas, Ontario Canada N5P 4L1  
 © 2013 Masco Corporation of Indiana