

# Cub Cadet®

## Operator's Manual

### 51cc 2-Cycle Chain Saw CS511

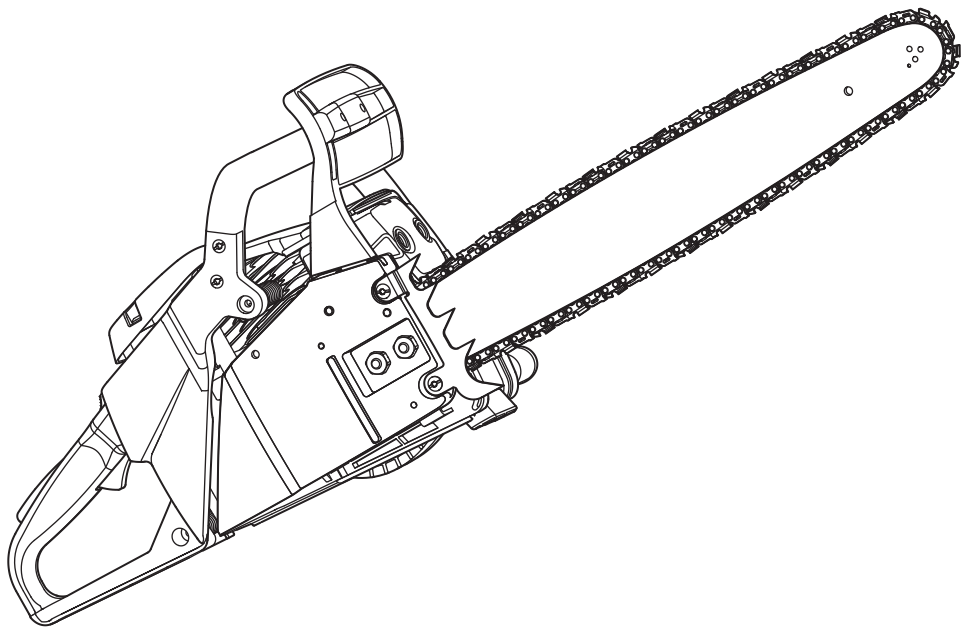

#### TABLE OF CONTENTS

Service Information .....	1
Safety Information .....	1
Know Your Unit .....	3
Assembly Instructions .....	3
Oil and Fuel Information .....	4
Starting and Stopping Instructions .....	4
Operating Instructions .....	5
Maintenance and Repair Instructions .....	6
Cleaning and Storage .....	8
Troubleshooting .....	8
Specifications .....	8
Warranty Information .....	24

All information, illustrations and specifications in this manual are based on the latest product information available at the time of printing. We reserve the right to make changes at any time without notice.  
Copyright© 2011 MTD SOUTHWEST INC, All Rights Reserved.

## SAVE THESE INSTRUCTIONS

#### SERVICE INFORMATION

**DO NOT RETURN THIS UNIT TO THE RETAILER. PROOF OF PURCHASE WILL BE REQUIRED FOR WARRANTY SERVICE.**

For assistance regarding the assembly, controls, operation or maintenance of the unit, please call the Customer Support Department at **1-877-282-8684** in the United States or **1-800-668-1238** in Canada. Additional information about the unit can be found on our website at [www.cubcadet.com](http://www.cubcadet.com) or [www.cubcadet.ca](http://www.cubcadet.ca).

For service, please call the Customer Support Department to obtain a list of authorized service dealers near you. Service on this unit, both within and after the warranty period, should only be performed by an authorized and approved service dealer. When servicing, use only identical replacement parts.

#### SPARK ARRESTOR NOTE

**NOTE: For users on U.S. Forest Land and in the states of California, Maine, Oregon and Washington.** All U.S. Forest Land and the state of California (Public Resources Codes 4442 and 4443), Oregon and Washington require, by law that certain internal combustion engines operated on forest brush and/or grass-covered areas be equipped with a spark arrestor, maintained in effective working order, or the engine be constructed, equipped and maintained for the prevention of fire. Check with your state or local authorities for regulations pertaining to these requirements. Failure to follow these requirements could subject you to liability or a fine. **This unit is factory equipped with a spark arrestor.** If it requires replacement, ask your LOCAL SERVICE DEALER to install the **Accessory Part #753-06268 Muffler.**

#### SAFETY INFORMATION

##### • SAFETY ALERT SYMBOLS •

Safety alert symbols are used to draw your attention to possible dangers. These symbols, and their explanations, deserve your careful attention and understanding. The safety warnings do not by themselves eliminate any danger. The instructions or warnings they give are not substitutes for proper accident prevention measures. These safety instructions are not meant to cover every possible condition that may occur. If questions arise, please call the Customer Support Department at **1-877-282-8684** (U.S.) or **1-800-668-1238** (Canada).

SYMBOL	MEANING
	<b>DANGER:</b> Signals an EXTREME hazard. Failure to obey a safety <b>DANGER</b> signal <b>WILL</b> result in serious injury or death to yourself or to others.
	<b>WARNING:</b> Signals a SERIOUS hazard. Failure to obey a safety <b>WARNING</b> signal <b>CAN</b> result in serious injury to yourself or to others.
	<b>CAUTION:</b> Signals a MODERATE hazard. Failure to obey a safety <b>CAUTION</b> signal <b>MAY</b> result in property damage or injury to yourself or to others.

**IMPORTANT!** Signals special mechanical information.  
**NOTE:** Signals additional important general information.

## • IMPORTANT SAFETY INSTRUCTIONS •

#### READ ALL INSTRUCTIONS BEFORE OPERATING

	<b>WARNING:</b> When using this unit, basic safety precautions should always be followed to reduce the risk of property damage and personal injury, including the following:
	<b>WARNING:</b> Engine exhaust, some of its constituents and certain finished components contain or emit chemicals known to the State of California to cause cancer and birth defects or other reproductive harm. Wash hands after handling.

#### BASIC SAFETY PRECAUTIONS

- **DO NOT** rely exclusively upon the safety devices built into the unit.
- **DO NOT** allow the unit to be used as a toy.
- Please read the entire operator's manual carefully before attempting to assemble, operate or maintain the unit.
- Follow all safety instructions. Failure to do so can result in property damage or serious injury to yourself and/or others.
- Be thoroughly familiar with the controls and the proper use of the unit. Know how to stop the unit and disengage the controls quickly.
- Stay alert! Do not operate the unit when tired, ill or under the influence of alcohol, drugs or medication.
- Never allow children to operate the unit. Never allow adults to operate the unit without proper instruction.
- Make sure that all guards and safety attachments are properly installed before operating the unit.
- Keep these instructions. Refer to them often and use them to instruct other users. If loaning someone this unit, also loan them these instructions.
- Keep bystanders, especially children and pets, at least 50 feet (15 m) away. If anyone enters the work area, stop the unit!
- Keep the work area clean. Cluttered areas invite injuries. Do not start cutting until the work area is clear and free from obstructions, there is secure footing and a planned retreat path from falling branches.
- Always wear appropriate eye and ear/hearing protection when operating this unit. Wear safety goggles, or safety glasses with side shields, that are marked as meeting ANSI Z87.1-1989 standards. Failure to do so could result in serious eye injury caused by thrown or falling objects. If the operation is dusty, wear a face mask or dust mask. Use a hard hat or other type of safety helmet.
- Dress appropriately, wear heavy, snug-fitting clothes (long pants and a long sleeve shirt), non-slip protective gloves and steel-toed safety boots. Do not wear loose clothing, jewelry, short pants, sandals or go barefoot. Secure hair above shoulder level to prevent entanglement in moving parts.
- Only use the unit in daylight or good artificial light.
- Only use the unit for its intended purpose: to cut wood. Only use the unit as described in this manual. Only use the manufacturer's recommended attachments with this unit.

#### UNDERSTANDING KICKBACK

	<b>DANGER:</b> Kickback may occur when the nose or tip of the guide bar touches an object, or when the wood closes in and pinches the saw chain in the cut. In some cases, tip contact may cause a lightning-fast reverse action, kicking the guide bar rapidly back towards the operator. Pinching the saw chain along the top of the guide bar may push the guide bar rapidly back towards the operator. Either of these reactions may cause a loss of control over the saw, which could result in serious injury to the user. Contact with foreign objects within the wood can also induce a loss of chain saw control.
--	--

- **Rotational Kickback** can happen when the upper tip of the guide bar contacts an object while the chain is moving (Fig. 1 & 2). This can cause the chain to dig into the object and momentarily stop moving. The guide bar is then kicked up and back toward the operator in a lightning-fast reverse reaction.
- **Pinch Kickback** can happen when the wood on either side of a cut closes in and pinches the moving saw chain along the top of the guide bar. This can cause the chain to instantly stop. The chain force is then reversed, causing the saw to move in the opposite direction, sending the saw straight back toward the operator.
- **Pull-In** can happen when the moving chain on the bottom of the guide bar hits a foreign object inside the wood. This can cause the chain to suddenly stop. The saw is then pulled forward and away from the operator, which could potentially result in the loss of control of the saw.

#### KICKBACK SAFETY PRECAUTIONS

- **DO NOT** over reach.
- **DO NOT** cut above shoulder height.
- **DO NOT** make cuts with the tip of the guide bar (Fig. 1).
- **DO NOT** let the tip of the guide bar contact any object, such as a log, branch, ground or other obstruction. Remove or avoid any obstructions that might impact the tip of the guide bar while cutting (Fig. 3).
- **DO NOT** cut more than one log or branch at a time.
- **DO NOT** twist the saw when removing the guide bar from an undercut while bucking.
- **DO NOT** operate the unit with one hand! Serious injury to the operator, helpers or bystanders may result from one-handed operation. This unit is intended for two-handed use. Always grip the unit firmly with both hands when the engine is running. Keep the left hand on the front handle and the right hand on the rear handle. Use a firm grip with thumbs and fingers encircling the handles. A firm grip will help maintain control of the unit and reduce kickback. Do not let go! Stand slightly to the left of the unit to avoid being in the direct line of the saw chain. Follow all the *Proper Grip on Handles* instructions in the *Operating Instructions* section.

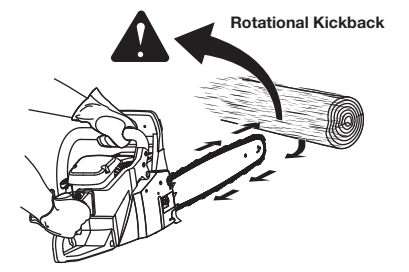

Fig. 1

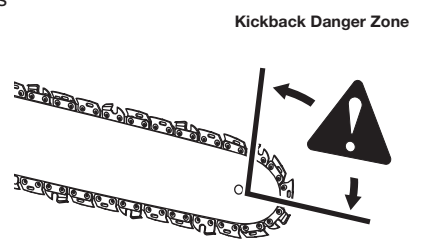

Fig. 2

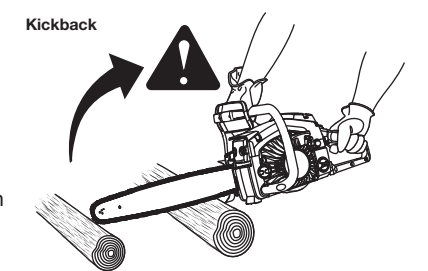

Fig. 3

## SAFETY INFORMATION

- **DO NOT** install a bow guide on this unit. Bow guides have a larger kickback zone, which increases the chance of kickback and serious injury. This increased risk is not significantly reduced by using a low kickback saw chain. Using a bow guide on this unit is extremely dangerous.
- Never start the saw when the guide bar is inside an existing cut. Be extremely careful when re-entering a cut.
- Keep proper footing and balance at all times.
- Always begin a cut with the engine running at full speed. Fully squeeze the throttle control trigger and maintain a steady cutting speed. Slower speeds increase the chance of kickback. Keep the saw housing pressed firmly against the wood.
- Watch for shifting logs, branches, or other objects that might pinch, or fall onto, the chain while cutting.
- If using wedges, only use wedges made of plastic or wood. Do not use metal to hold a cut open.
- Follow the manufacturer's sharpening and maintenance instructions for the saw chain.
- Only use replacement guide bars and chains specified by the manufacturer or the equivalent. These are available from authorized service dealers. Use of any unauthorized parts or accessories could lead to serious injury to the operator or damage to the unit and will void the warranty.
- Use devices, such as low-kickback chains, guide bar nose guards, chain brakes and special guide bars, which reduce the risks associated with kickback. There are no other replacement components for achieving kickback protection in accordance with CSA Z62.3.
- Low-kickback saw chain is chain that has met the kickback performance requirements of ANSI B175.1-1991 and is in accordance with CSA Z62.3. Do not use a replacement chain unless it has met these requirements for the specific model. As saw chains are sharpened, some of the low kickback qualities are lost and extra caution should be used.

### GENERAL SAFETY PRECAUTIONS

- **DO NOT** handle the unit with wet hands.
- **DO NOT** operate a chain saw in a tree or on a ladder unless specifically trained to do so.
- **DO NOT** use the unit in the presence of flammable liquids or gases.
- **DO NOT** operate a unit that is damaged, improperly adjusted or not completely and securely assembled. Be sure that the saw chain stops moving when the throttle control trigger is released. Do not use the unit if the stop switch does not turn the unit on and off properly or if the lockout switch does not work. Have defective switches replaced by an authorized service center.
- **DO NOT** attempt operations beyond the operator's capacity or experience.
- **DO NOT** cut near electrical cables or power lines.
- **DO NOT** force the chain saw, especially near the end of a cut. It will do a better, safer job when used at the intended rate.
- **DO NOT** touch the engine or muffler. These parts can become extremely hot during operation and remain hot for a short time after the unit is turned off.
- To reduce the risk of fire, keep the engine and muffler free from debris, excessive grease and carbon build up.
- Before cutting, always inspect wood for foreign objects that could cause injury to the operator or damage to the unit. Never cut through nails, metal rods, railroad ties or pallets. If a foreign object is struck, stop the unit and inspect it for damage.
- Keep all body parts away from the saw chain when the engine is running. Before starting the saw, make sure the saw chain is not contacting anything.
- Always stop the engine when operation is delayed, before setting down the unit or when walking from one location to another. Make sure the chain comes to a complete stop. Do not leave the unit unattended while the engine is running. Always stop the engine when not in use.
- To avoid accidental starting, never carry the unit with fingers on the throttle control trigger. Only pull the starter rope when in the starting position. The operator and unit must be in a stable position while starting the engine. Refer to *Starting and Stopping Instructions*.
- Always carry the chain saw by the front handle with the engine off, finger off the throttle control trigger, the muffler positioned away from the body and the guide bar and saw chain sheathed in the scabbard and positioned to the rear.
- Always make sure the stop switch is in the proper position before starting or stopping the engine.
- When cutting a limb that is under tension, be alert for spring back, which may cause the operator to be struck when the tension of the wood fibers is released.
- Use extreme caution when cutting small-sized brush and saplings, as slender material may catch the saw chain and be whipped toward the operator or pull the operator off balance.
- This saw is classified by UL as a Class 1C saw in accordance with CSA Z62.1-03. It is intended for infrequent use by homeowners, cottagers and campers, and for general applications such as clearing, pruning, cutting firewood, etc. It is not intended for prolonged use. If the intended use involves prolonged periods of operation, this may cause circulatory problems in the user's hands due to vibration.

### GASOLINE SAFETY

	<b>WARNING:</b> Use caution when handling fuel. Gasoline is highly flammable, and its vapors can explode if ignited. Take the following precautions:
--	--

- **DO NOT** smoke while handling fuel or while operating the unit.
- Always keep a fire extinguisher nearby while operating the unit.
- Store fuel only in containers specifically designed and approved for the storage of such materials.
- Always stop the engine and allow it to cool before filling the fuel tank. Never remove the fuel tank cap or add fuel when the engine is hot. Always loosen the fuel tank cap slowly to relieve any pressure in the tank before fueling. Do not smoke.
- Always mix and add fuel in a clean, well-ventilated outdoor area where there are no sparks or flames. Do not smoke.
- Never operate the unit without the fuel cap securely in place.
- Avoid creating a source of ignition for spilled fuel. Wipe up any spilled fuel from the unit immediately before starting the unit. Move the unit at least 30 feet (9.1 m) from the fueling source and site before starting the engine. Do not smoke.
- Never start or run the unit inside a closed room or building. Breathing exhaust fumes can kill. Operate this unit only in a well-ventilated outdoor area.
- Always store the unit and fuel in a cool, dry and well-ventilated space where fuel vapors cannot reach sparks or open flames from water heaters, electric motors or switches, furnaces, etc. Never store the unit, with fuel in the tank, inside a building where fumes may reach an open flame or spark.

### MAINTENANCE AND STORAGE SAFETY

- If the unit is not working as it should, has been dropped, damaged, left outdoors or dropped into water, do not use the unit. Have the unit serviced by an authorized service center.
- All service, other than the maintenance procedures described in this manual, should be performed by an authorized service center.
- Follow all maintenance instructions in this manual.
- Before inspecting, servicing, cleaning, storing, transporting or replacing any parts on the unit:
  1. Stop the engine. Make sure the stop switch is in the STOP position and the throttle control trigger is released.
  2. Make sure all moving parts have stopped.
  3. Allow the unit to cool.
  4. Make sure the chain brake is disengaged.
- Never remove, modify or make inoperative any safety device furnished with the unit.
- For safer, more effective performance, make sure the guide bar and chain are properly cleaned, lubricated, tightened and sharpened. Check the guide bar and chain at frequent intervals for proper adjustment.
- Frequently inspect the unit for damage. Before further use, any damaged part should be carefully checked to determine that it will operate properly and perform its intended function. Check for alignment of moving parts, binding of moving parts, breakage of parts, fuel leaks and any other conditions that may affect its operation. Damaged parts should be properly repaired or replaced by an authorized service center, unless otherwise indicated in this manual.
- Use only original manufacturer replacement parts and accessories, which are designed specifically to enhance the performance and maximize the safe operation of the product. Failure to do so may cause poor performance and possible injury. Use only the chain and guide bar supplied with this product.
- Be sure to secure the unit while transporting.
- Always use the scabbard on the guide bar and saw chain during transportation and storage.
- When not in use, store the unit in a locked-up and dry, or high and dry, place to prevent unauthorized use or damage. Keep out of the reach of children.
- Keep the handles dry, clean and free from debris, oil, fuel and grease. Clean the unit after each use. Never douse or spray the unit with water or any other liquid. Do not use solvents or strong detergents.

### • SAFETY AND INTERNATIONAL SYMBOLS •

This operator's manual describes safety and international symbols and pictographs that may appear on this product. Read the operator's manual for complete safety, assembly, operating, maintenance and repair information.

SYMBOL	MEANING
	<ul style="list-style-type: none"> <li>• <b>SAFETY ALERT SYMBOL</b> Indicates danger, warning or caution. May be used in conjunction with other symbols or pictographs.</li> </ul>
	<ul style="list-style-type: none"> <li>• <b>READ OPERATOR'S MANUAL</b> <b>WARNING:</b> Read the operator's manual(s) and follow all warnings and safety instructions. Failure to do so can result in serious injury to the operator and/or bystanders.</li> </ul>
	<ul style="list-style-type: none"> <li>• <b>WEAR HEAD, EYE AND HEARING PROTECTION</b> <b>WARNING:</b> Thrown objects and loud noise can cause severe eye injury and hearing loss. Wear eye protection meeting ANSI Z87.1-1989 standards and ear protection when operating this unit. Wear head protection when operating this unit; falling objects can cause severe head injury. Use a full face shield when needed.</li> </ul>
	<ul style="list-style-type: none"> <li>• <b>KEEP BYSTANDERS AWAY</b> <b>WARNING:</b> Keep all bystanders, especially children and pets, at least 50 feet (15 m) from the operating area. If anyone enters the work area, stop the unit!</li> </ul>
	<ul style="list-style-type: none"> <li>• <b>WEAR SAFETY GLOVES</b> Wear non-slip, heavy-duty protective gloves when handling the unit.</li> </ul>
	<ul style="list-style-type: none"> <li>• <b>WEAR SAFETY FOOTWEAR</b> Wear non-slip safety footwear when using this equipment.</li> </ul>
	<ul style="list-style-type: none"> <li>• <b>USE BOTH HANDS</b> Always use both hands while operating the chain saw. Never use only one hand to operate the unit.</li> </ul>
	<ul style="list-style-type: none"> <li>• <b>KICKBACK WARNING</b> Contact of the guide bar tip with any object should be avoided. Tip contact may cause the guide bar to move suddenly upward and backward, which may cause serious injury.</li> </ul>
	<ul style="list-style-type: none"> <li>• <b>UNLEADED FUEL</b> Always use clean, fresh unleaded fuel</li> </ul>
	<ul style="list-style-type: none"> <li>• <b>DO NOT USE E85 FUEL IN THIS UNIT</b> <b>WARNING:</b> It has been proven that fuel containing greater than 10% ethanol will likely damage this engine and void the warranty.</li> </ul>
	<ul style="list-style-type: none"> <li>• <b>OIL</b> Refer to operator's manual for the proper type of oil.</li> </ul>
	<ul style="list-style-type: none"> <li>• <b>ON/OFF STOP CONTROL</b> ON / START / RUN</li> </ul>
	<ul style="list-style-type: none"> <li>• <b>ON/OFF STOP CONTROL</b> OFF or STOP</li> </ul>
	<ul style="list-style-type: none"> <li>• <b>PRIMER BULB</b> Push primer bulb, fully and slowly, 10 times.</li> </ul>
	<ul style="list-style-type: none"> <li>• <b>CHOKE CONTROL</b> <ol style="list-style-type: none"> <li>1. • <b>FULL</b> choke position</li> <li>2. • <b>RUN</b> position</li> </ol> </li> </ul>

## SAVE THESE INSTRUCTIONS

## KNOW YOUR UNIT

### APPLICATIONS

This unit may be used for the purposes listed below:

- Basic limbing, felling and woodcutting
- Removing buttress roots

### TOOLS REQUIRED:

- Damp Cloth
- Small Flathead Screwdriver
- Multi-purpose Tool (included)

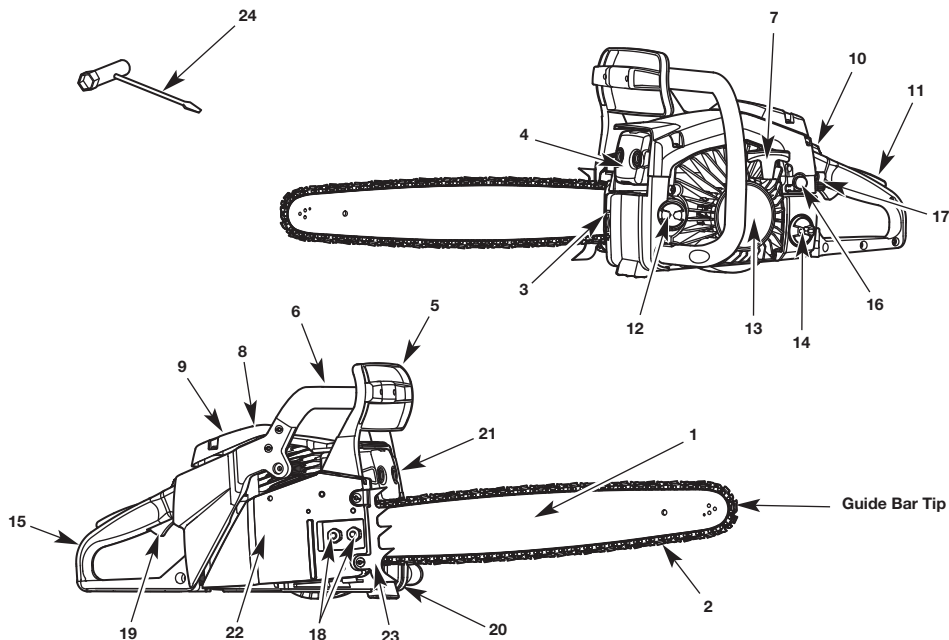

### CHAIN SAW COMPONENTS

- |   |                                   |
|---|-----------------------------------|
| 1. GUIDE BAR                            | 13. STARTER COVER                 |
| 2. LOW KICKBACK SAW CHAIN               | 14. FUEL TANK CAP                 |
| 3. CHAIN-TENSIONING SCREW               | 15. REAR HANDLE / BOOT LOOP       |
| 4. SPARK ARRESTER SCREEN                | 16. PRIMER BULB                   |
| 5. CHAIN BRAKE LEVER / FRONT HAND GUARD | 17. CHOKE LEVER                   |
| 6. FRONT HANDLE                         | 18. BAR-RETAINING NUTS            |
| 7. STARTER HANDLE                       | 19. THROTTLE CONTROL TRIGGER      |
| 8. SPARK PLUG                           | 20. CHAIN CATCHER                 |
| 9. AIR FILTER COVER                     | 21. MUFFLER SHIELD                |
| 10. STOP SWITCH                         | 22. GUIDE BAR COVER               |
| 11. SAFETY LATCH                        | 23. SPIKED BUMPER / BUCKING SPIKE |
| 12. BAR LUBE RESERVOIR CAP              | 24. MULTI-PURPOSE TOOL            |

### SAFETY FEATURES

Numbers preceding the descriptions correspond with the numbers above to help you locate the safety feature.

2. LOW KICKBACK SAW CHAIN helps significantly reduce kickback, or the intensity of kickback, due to specially designed depth gauges and guard links.
4. SPARK ARRESTER SCREEN retains carbon and other flammable particles over 0.023 inches (0.6mm) in size from engine exhaust flow. Compliance with local, state and federal laws and/or regulations governing the use of a spark arrester screen is the user's responsibility. See *Safety Information* for additional information.
5. CHAIN BRAKE LEVER / FRONT HAND GUARD helps protect the operator's left hand in the event it slips off the front handle while the unit is running.  
CHAIN BRAKE is designed to reduce the possibility of injury due to kickback by stopping a moving saw chain in milliseconds. It is activated when pressure is applied to the chain brake lever, as in the event of the operator's hand striking the lever during kickback.
10. STOP SWITCH immediately stops the engine when moved to the STOP position. The stop switch must be pushed to the RUN position to start or restart the engine.
11. SAFETY LATCH prevents accidental acceleration of the engine. The throttle control trigger (20) cannot be squeezed unless the safety latch is depressed.
20. CHAIN CATCHER reduces the danger of injury in the event the saw chain breaks or derails during operation. The chain catcher is designed to intercept a whipping chain.

## ASSEMBLY INSTRUCTIONS

This unit requires assembly.

### UNPACKING

- Carefully remove the product and any accessories from the box.
- Inspect the product carefully to make sure no breakage or damage occurred during shipping.
- Do not discard the packing material until you have carefully inspected and satisfactorily operated the product.
- If any parts are damaged or missing, please call 1-877-282-8684 (U.S.) or 1-800-668-1238 (Canada) for assistance.



**WARNING:** Make sure the stop switch is in the STOP position before inspecting, adjusting, fueling or performing maintenance on any part of the unit. Failure to do so can result in serious personal injury. Refer to *Starting and Stopping Instructions*.

### ASSEMBLING THE GUIDE BAR AND SAW CHAIN

Refer to *Removing/Replacing the Guide Bar and Chain* in the *Maintenance and Repair Instructions* section.

### ADDING BAR AND CHAIN LUBRICANT

The guide bar and saw chain require lubrication to minimize friction. Never starve the guide bar and chain of lubricating oil. Running the unit without enough oil will decrease cutting efficiency, shorten the life of the saw chain, cause rapid dulling of the saw chain and excessive wear to the guide bar from overheating. An insufficient amount of lubricating oil is evidenced by smoke, guide bar discoloration or pitch build-up.



**WARNING:** Make sure the bar lube reservoir is always filled. Failure to fill the bar lube reservoir will cause irreparable damage to the unit.

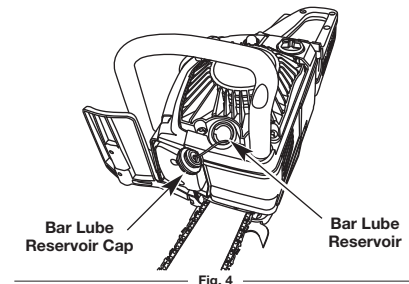

Fill the bar lube reservoir each time the fuel tank is filled. Only use bar and chain oil that is formulated to perform over a wide range of temperatures with no diluting required in the bar lube reservoir. Do not use motor oil or any other petroleum-based oil.

**NOTE:** This chain saw comes from the factory with the bar lube reservoir empty. Use the bottle of bar and chain oil that is included with the unit.

**NOTE:** Always clean the bar lube reservoir cap and surrounding area before adding bar and chain lubricant. Use a damp cloth. This helps prevent debris from entering the bar lube reservoir.

1. Remove the bar lube reservoir cap (Fig. 4).
2. Carefully pour the bar and chain oil into the bar lube reservoir.
3. Replace the bar lube reservoir cap and tighten securely.
4. Wipe off excess oil.

**NOTE:** Bar lube reservoirs are designed to keep oil slowly flowing onto the chain. This unit will use approximately one tank of bar and chain oil for every tank of fuel. If the oil flow to the guide bar and chain is too much or too little, refer to *Adjusting the Automatic Oiler* in the *Maintenance and Repair Instructions* section.

**NOTE:** Do not use dirty, used or otherwise contaminated oils. Damage may occur to the guide bar or chain.

**IMPORTANT!** Please dispose of oil properly. Consult your local waste authority for information regarding available disposal options.

### FUELING THE ENGINE

This unit is designed to operate on a mixture of unleaded gasoline and 2-cycle engine oil. Refer to *Oil and Fuel Information* for complete mixing instructions and detailed fuel requirements.

**NOTE:** Always clean the fuel tank cap and surrounding area before fueling the unit. Use a damp cloth. This helps prevent debris from entering the fuel tank.

1. Turn the unit on its side so that the fuel tank is facing up (Fig. 5).
2. Slowly unscrew and remove the fuel tank cap by turning it counterclockwise.
3. Slowly pour the proper fuel/oil mixture into the fuel tank until the tank is full.
4. Replace the fuel tank cap and turn it clockwise to secure it tightly.
5. Wipe off any spilled fuel.

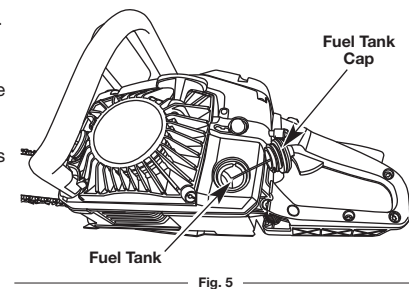

### TESTING THE CHAIN BRAKE



**WARNING:** When activating the chain brake, do so slowly and deliberately. Keep the saw chain from touching anything; don't let the saw tip forward.

Always test the chain brake before using the unit and periodically during operation. Follow these instructions to make sure the chain brake is working correctly:

1. Place the unit on a clear, firm and flat surface.
2. Pull the chain brake lever back to disengage the chain brake.
3. Start the unit. Refer to *Starting and Stopping Instructions*. Be sure to maintain a proper grip. Refer to *Proper Grip on Handles* in the *Operating Instructions* section.
4. While the unit is running, squeeze the throttle control trigger to 1/3 throttle and then engage the chain brake by pushing the chain brake lever forward with the left hand (Fig. 6).

The chain should stop moving abruptly. If it does, immediately release the throttle control trigger, turn off the engine and return the chain brake to the disengaged position. Refer to *Starting and Stopping Instructions*.

If the chain does not stop when the chain brake is engaged, release the throttle control trigger, stop the engine and have the unit serviced by an authorized service center.

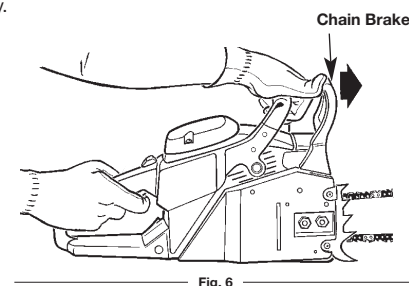

**WARNING:** The chain must not move when the engine runs at idle speed. If it does move at idle speed, refer to the *Carburetor Adjustment* instructions in the *Maintenance and Repair Instructions* section. Avoid contact with the muffler. A hot muffler can cause serious burns.

## OIL AND FUEL INFORMATION

**CAUTION:** For proper engine operation and maximum reliability, pay strict attention to the oil and fuel mixing instructions on the 2-cycle oil container. Using improperly mixed fuel can severely damage the engine.

**WARNING:** Gasoline is extremely flammable. Ignited vapors may explode. Always stop the engine and allow it to cool before filling the fuel tank. Do not smoke while filling the tank. Keep sparks and open flames at a distance from the area.

**WARNING:** Remove the fuel cap slowly to avoid injury from fuel spray. Never operate the unit without the fuel cap securely in place.

**WARNING:** Add fuel in a clean, well-ventilated outdoor area. Wipe up any spilled fuel immediately. Avoid creating a source of ignition for spilled fuel. Do not start the engine until fuel vapors dissipate.

### OIL AND FUEL MIXING INSTRUCTIONS

Old fuel and improperly mixed fuel are the two main reasons why the unit may not run properly. Be sure to use fresh, clean unleaded gasoline and quality synthetic 2-cycle air-cooled engine oil. Do not use automotive oil or boat oil; these oils will damage the engine.

#### Obtaining the Correct Fuel/Oil Mixture

Thoroughly mix the proper amount of 2-cycle engine oil with unleaded gasoline in a separate fuel container (do not mix them directly in the engine fuel tank). Use a 40:1 fuel/oil ratio. See the table for specific gas and oil mixing ratios.

**NOTE:** One gallon (3.8 liters) of unleaded gasoline mixed with one 3.2 oz. (95 ml) bottle of 2-cycle oil makes a 40:1 fuel/oil ratio.

When mixing fuel, follow the instructions printed on the oil container. Always read and follow the safety rules relating to fuel before fueling the unit.

**NOTE:** Dispose of any old fuel/oil mix in accordance with federal, state and local regulations.

#### Using Blended Fuels

**WARNING: DO NOT USE E85 FUEL IN THIS UNIT.** It has been proven that fuel containing greater than 10% ethanol will likely damage this engine and void the warranty.

Today's fuels are often a blend of gasoline and oxygenates such as ethanol, methanol or MTBE (ether). These alcohol-blended fuels absorb water. As little as 1% water in the fuel can make fuel and oil separate, which leads to the formation of acids during storage.

If you choose to use a blended fuel, or its use is unavoidable, follow these precautions:



- Always use fresh fuel (less than 30 days old)
- Mix the fresh unleaded fuel with 2-cycle engine oil, as directed above
- Use the fuel additive STA-BIL® or an equivalent
- Always agitate the fuel mix before fueling the unit
- Drain the fuel tank and run the engine dry before storing the unit

#### Using Fuel Additives

The bottle of 2-cycle oil that came with this unit contains a fuel additive that will help inhibit corrosion and minimize the formation of gum deposits. Using the 2-cycle oil included with this unit is recommended.

If unavailable, use a good 2-cycle oil designed for air-cooled engines along with a fuel additive, such as STA-BIL® Gas Stabilizer or an equivalent. Add 0.8 oz. (23 ml) of fuel additive per gallon of fuel according to the instructions on the container. NEVER add fuel additives directly to the unit's fuel tank.

**NOTE:** Never use engine or carburetor cleaner products in the fuel tank or permanent damage can occur.

	
<b>UNLEADED GAS</b>	<b>2 CYCLE OIL</b>
<b>1 GALLON US (3.8 LITERS)</b>	<b>3.2 FL. OZ. (95 ml)</b>
<b>1 LITER</b>	<b>25 ml</b>

**MIXING RATIO - 40:1**

## STARTING AND STOPPING INSTRUCTIONS

**WARNING:** Only operate this unit in a well-ventilated outdoor area. Carbon monoxide exhaust fumes can be lethal in a confined area.

**WARNING:** Never operate the unit without the guide bar and saw chain properly installed.

### BEFORE STARTING THE ENGINE

- Make sure the chain tension is at the desired setting. Refer to *Adjusting the Chain Tension* in the *Maintenance and Repair* section.
- Make sure the bar-retaining nuts are tight to the guide bar cover.
- Make sure the fuel tank is filled with fresh fuel. Refer to *Oil and Fuel Information*. If the oil and fuel instructions are not understood, do not attempt to fuel the unit!
- Make sure the bar lube reservoir is filled with bar and chain oil. Refer to *Adding Bar and Chain Lubricant* in the *Assembly Instructions* section.
- Make sure the chain brake is disengaged by pulling the front hand guard / chain brake back toward the front handle as far as possible. Refer to *Testing the Chain Brake* in the *Assembly Instructions* section.
- Make sure the immediate area is clear of any objects or obstructions that could come in contact with the guide bar and chain.

### STARTING THE ENGINE

To help prevent accidental start-ups, this unit has a stop switch, safety latch and a throttle control trigger that must be used together to start the unit.

1. Move the stop switch down to the RUN position (Fig. 7).
2. Fully press and release the primer bulb 10 times, slowly (Fig. 7). Some amount of fuel should be visible in the primer bulb. If fuel cannot be seen in the bulb, press and release the bulb until fuel is visible.
3. Move the choke lever to **Position 1** (Fig. 8). This will lock the throttle into the wide open position.
4. **Do not touch the throttle control trigger.** Place the unit on a firm, flat surface. Crouch in the starting position and hold the unit firmly, as shown (Fig. 9). Grip the front handle with the left hand and put the right foot in the boot loop.

**NOTE:** This unit uses the AST starting system, which significantly reduces the effort required to start the engine. You must pull the starter rope out far enough to hear the engine attempt to start. There is no need to pull the rope briskly - there is no harsh resistance when pulling. Do not pull the rope to its limit, as this may cause the rope to break. Do not let the rope snap back. Hold the handle and let the rope rewind slowly. Be aware that this starting method is vastly different from (and much easier than) what you may be used to.

6. **Do not touch the throttle control trigger.** Move the choke lever to **Position 2** (Fig. 8).
7. **Do not touch the throttle control trigger.** Pull the starter rope **3-5** times in a controlled and steady motion to start the engine.
8. **Do not touch the throttle control trigger.** Allow the engine to warm up for 30-60 seconds.
9. Depress and release the throttle control trigger to idle the engine. The unit is now ready for use.

**IF...** The engine does not start, go back to step 2.

**IF...** The engine fails to start after a few attempts, move the choke lever to **Position 2** and squeeze the throttle control trigger. Pull the starter rope **3-8** times in a controlled and steady motion. The engine should start. If not, repeat.

**IF...** The unit idles roughly, use a Phillips or standard screwdriver to turn the idle adjustment screw (Fig. 10) 1/4 to 1/2 turn clockwise or until the unit idles smoothly.

**IF...** The saw chain turns while the unit is idling, use a Phillips or standard screwdriver to turn the idle adjustment screw (Fig. 10) counterclockwise until the saw chain stops and the unit continues to idle.

**IF...** The engine starts and idles smoothly, begin the chain brake test. Refer to *Testing the Chain Brake* in the *Assembly Instructions* section.

**IF WARM...** If the engine is already warm, perform steps 6 - 9 to start the unit.

### STOPPING THE ENGINE

1. Release the throttle control trigger and allow the engine to return to idle speed.
2. Move the stop switch up to the STOP position (Fig. 7).

**NOTE:** It is normal for the chain to coast to a stop once the stop switch is in the STOP position.

**NOTE:** For emergency stopping, push the chain brake lever / hand guard forward to engage the chain brake and then move the stop switch up to the STOP position.

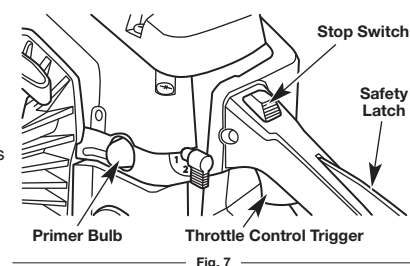

Fig. 7

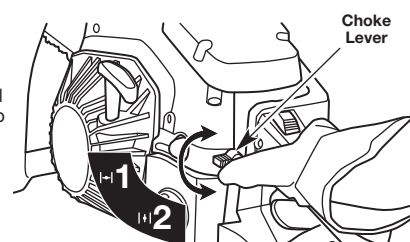

Fig. 8

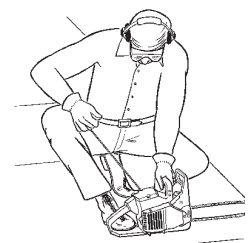

Fig. 9

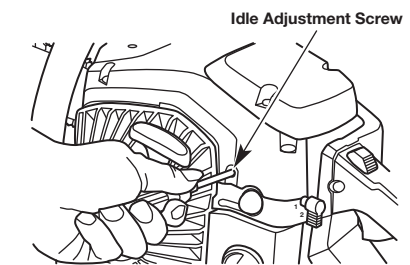

Fig. 10

# OPERATING INSTRUCTIONS

**WARNING:** Do not allow familiarity with this unit to promote carelessness. Remember that a careless fraction of a second is enough to inflict serious injury.

**WARNING:** If any parts are damaged or missing, do not operate the unit until the parts are replaced. Failure to heed this warning could result in serious personal injury.

**WARNING:** Always wear appropriate eye and ear/hearing protection when operating this unit. Wear safety goggles, or safety glasses with side shields, that are marked as meeting ANSI Z87.1-1989 standards. Failure to do so could result in serious eye injury caused by thrown objects. If the operation is dusty, wear a face mask or dust mask. Use a hard hat or other type of safety helmet.

**WARNING:** Wear non-slip gloves for maximum grip and protection. Refer to the *Safety Information* section for appropriate safety equipment.

## PROPER GRIP ON HANDLES

- Hold the saw firmly with both hands. Always keep the left hand on the front handle and the right hand on the rear handle so that the operator's body is to the left of the chain line (Fig. 11). Use these hand placements even if the operator is left-handed.
- Maintain a proper grip on the saw whenever the engine is running. The fingers should encircle the handle and the thumb should wrap under the handle (Fig. 12). This grip is least likely to be broken by a kickback or other sudden reaction of the saw. Any grip in which the thumb and fingers are on the same side of the handle is dangerous because a slight kick of the saw can cause loss of control (Fig. 13).

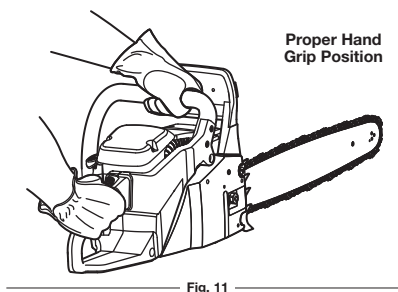

## PROPER CUTTING STANCE

**WARNING:** Do not operate the throttle control trigger with the left hand while holding the front handle with the right hand. Never allow any part of your body to be in the chain line while operating a saw (Fig. 14).

- Balance body weight securely, with both feet on solid ground.
- Keep the left arm locked in a "straight arm" position to withstand any kickback force (Fig. 15).
- Keep all body parts to the left of the chain line (Fig. 15).
- Make sure the proper grip is established on the front handle and rear handle.
- Do not cut above chest height as a saw held higher is difficult to control against kickback forces.

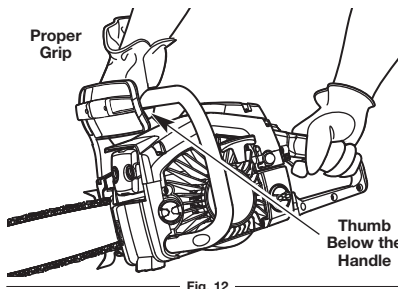

## BASIC OPERATING/CUTTING PROCEDURES

- This unit has a 18" guide bar and is designed to cut logs or trees with diameters of 14" or less. Cutting larger trees or logs is not recommended.
- Practice cutting a few small logs using the following technique to get the "feel" of using the saw before you begin a major sawing operation.
- Take the proper stance in front of the wood or tree to be cut.
- Start the engine and let the chain accelerate to full speed before starting the cut. Refer to *Starting and Stopping Instructions*.
- Begin cutting with the saw against the log.
- Keep the unit running the entire time while cutting, making sure to maintain a steady speed.
- Allow the chain to do the cutting; exert only light downward pressure. Forcing the cut could result in damage to the guide bar, chain or engine.
- Release the throttle control trigger as soon as the cut is completed. Allow the chain to come to a complete stop. Unnecessary wear may occur to the chain, guide bar and unit if the saw is run without a cutting load.
- Do not put pressure on the saw at the end of the cut.

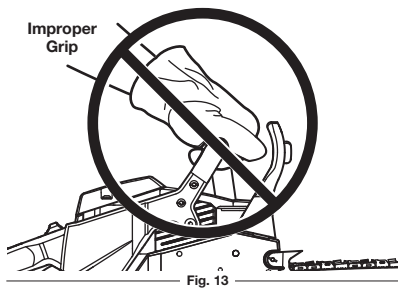

## WORK AREA PRECAUTIONS

- Cut only wood or materials made from wood. Do not attempt to cut sheet metal, plastics, masonry or non-wood building materials.
- Keep everyone – helpers, bystanders, children and animals – 50 feet (15 m) away from the cutting area. If anyone enters the work area, stop the unit! During felling operations, the safe distance should be at least twice the height of the largest trees in the felling area. During bucking operations, keep a minimum distance of 15 feet (4.6 m) between workers.
- Only operate the unit when visibility and light are adequate to see clearly.

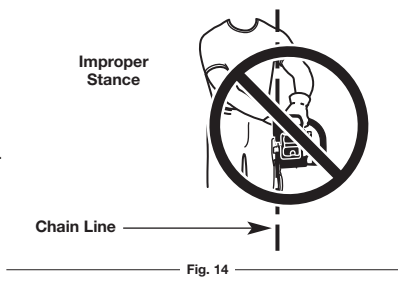

## REMOVING BUTTRESS ROOTS

A buttress root is a large root extending from the trunk of the tree above the ground. Remove large buttress roots prior to felling (Fig. 16).

- Make the horizontal cut into the buttress first, followed by the vertical cut.
- Remove the resulting loose section from the work area.
- Remove any remaining large buttress roots.

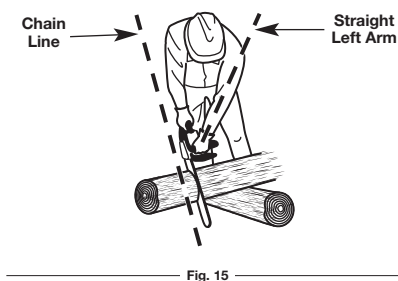

## FELLING

**WARNING:** Do not fell trees during periods of precipitation or high wind.

Felling is the term for cutting down a tree. When felling a tree, it is important to heed the following warnings to reduce the risk of serious injury:

- Do not cut down trees having an extreme lean or large trees with rotten limbs, loose bark or hollow trunks. Have these trees pushed or dragged down with heavy equipment, then cut them up.
- Do not cut trees near electrical wires or buildings. Leave this operation for professionals.
- Check the tree for damaged or dead branches that could fall and cause serious personal injury.
- Periodically glance at the top of the tree during the back cut to see if the tree is going to fall in the desired direction.
- If the tree starts to fall in the wrong direction, or the saw gets caught or hung up during the fall, leave the saw and evacuate the area immediately!
- When bucking and felling operations are being performed by two or more persons, at the same time, the felling operation should be separated from the bucking operation by a distance of at least twice the height of the tree being felled. Trees should not be felled in a manner that would endanger any person, strike any utility line or cause any property damage. If the tree does make contact with any utility line, the utility company should be notified immediately.
- The operator should keep on the uphill side of terrain, as the tree is likely to roll or slide after it is felled.
- Pick your escape route (or routes in case the intended route is blocked). Clear the immediate area around the tree and make sure there are no obstructions in your planned path of retreat. Clear the path of safe retreat approximately 135° from the planned line of fall (Fig. 17).
- Consider the force and direction of the wind, the lean and balance of the tree and the location of large limbs. These things influence the direction in which the tree will fall. Do not try to fell a tree along a line different from its natural line of fall.
- Remove dirt, stones, loose bark, nails, staples and wire from the tree where felling cuts are to be made.

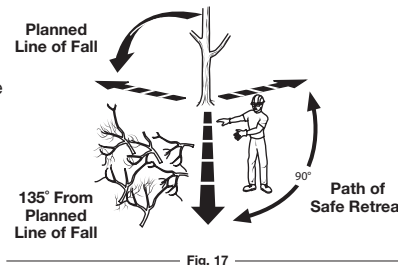
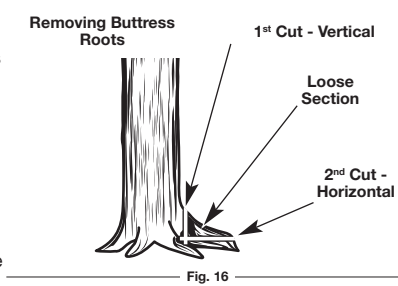

**WARNING:** Never walk in front of a tree that has been notched.

Small trees, up to 6-7 inches (15-18 cm) in diameter, are usually felled in a single cut. Larger trees require a process consisting of two main cutting operations: a notched undercut followed by a felling back cut.

- Notched Undercut.** This cut determines the direction that the tree will fall. It should be made on the side of the tree facing the felling direction. Cut a notch about 1/3 the diameter of the trunk in the side of the tree. Make the notch cuts so they intersect at a right angle to the line of fall. This notch should be cleaned out to leave a straight line. To keep the weight of the wood off the saw, always make the lower cut of the notch before the upper cut. (Fig. 18)
- Felling Back Cut.** This cut fells the tree. Make the back cut level and horizontal, and at a minimum of 2 inches (5 cm) above the horizontal cut of the notch (Fig. 18). If the diameter of the tree is greater than the length of the guide bar, make two cuts as shown (Fig. 19). When the felling cut gets close to the hinge, the tree should begin to fall (Fig. 20). If there is any chance the tree may not fall in the desired direction or if it may rock back and bind the saw chain, stop cutting before the felling cut is complete and use wedges of wood or plastic to open the cut and drop the tree along its desired line of fall (Fig. 21).

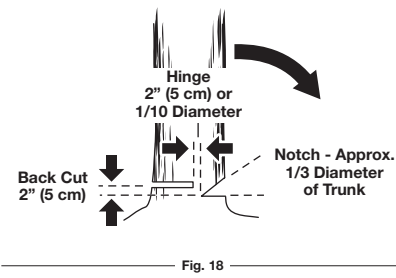

**WARNING:** Before making the final cut, always recheck the area for bystanders, animals and obstacles.

**NOTE:** On large diameter trees, stop the back cut before it is deep enough for the tree to either fall or settle back on the stump. Then insert soft wooden or plastic wedges into the cut so that they do not touch the chain. Drive wedges in, little by little, to help jack the tree over.

**WARNING:** Never cut through to the notch. Always leave a band of wood between the notch and back cut (approximately 2 inches (5 cm) or 1/10 the diameter of the tree). This is called "hinge" or "hingewood." It controls the fall of the tree and prevents slipping, twisting or shootback of the tree off the stump.

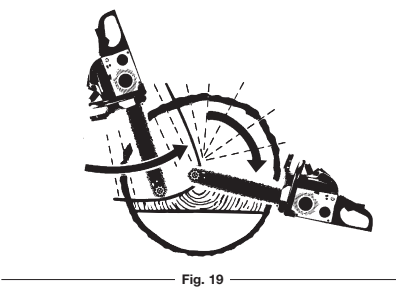

- As the tree starts to fall, remove the chain saw from the cut, stop the engine and put down the unit immediately. Retreat along the cleared path, but watch the action in case something falls along the retreat path.

## LIMBING

Limbing is the process of removing branches from a fallen tree (Fig. 22).

- Work slowly, while maintaining a proper grip and stance.
- Leave the larger support limbs under the tree to keep the tree off the ground while cutting.
- Limbs should be cut one at a time. Remove the cut limbs from the work area often to help keep the work area clean and safe.
- Branches under tension should be cut from the bottom up to avoid binding the chain saw.
- Keep the tree between you and the chain saw while limbing. Cut from the side of the tree opposite the branch that is being cut.

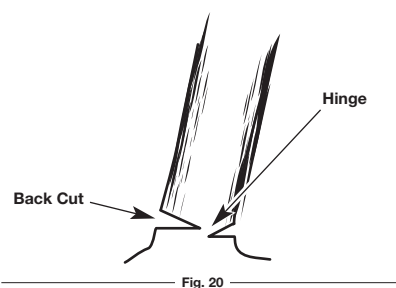

## BUCKING

Bucking is the process of cutting a fallen tree into desired log lengths.

- Work slowly, while maintaining a proper grip and stance.
- Cut only one log at a time.
- Keep a clear cutting area. Make sure that no objects can contact the guide bar nose and chain during cutting; this can cause kickback. Refer to *Understanding Kickback in the Safety Information* section.
- When bucking on a slope, always stand on the uphill side of the log. To maintain complete control of the chain saw when cutting through the log, release the cutting pressure near the end of the cut without relaxing the grip on the chain saw handles. Do not let the chain contact the ground. After completing the cut, wait for the saw chain to stop before moving the chain saw. Always stop the engine before moving from log to log.

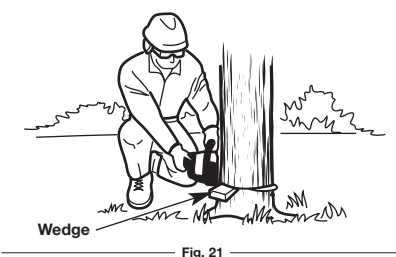

**NOTE:** If possible, the log should be supported so that the end to be cut off is not resting on the ground. The best way to hold a log while bucking is to use a sawhorse. When this is not possible, the log should be raised and supported by the limb stumps or by using supporting logs. Be sure the log being cut is securely supported.

## Bucking Logs Under Stress

Make the first bucking cut 1/3 of the way through the log and finish with a 2/3 cut on the opposite side. The log will tend to bend as it is being cut. The saw may become pinched or hung in the log if the first cut is deeper than 1/3 of the diameter of the log. Give special attention to logs under stress to prevent the guide bar and chain from pinching.

- When the log is supported on one end (Fig. 23): First, cut from the bottom (underbuck) 1/3 of the way through the log to avoid splintering. Second, cut from above (overbuck) to meet the first cut and avoid pinching.
- When the log is supported on both ends (Fig. 24): First, overbuck 1/3 of the way through the log to avoid splintering. Second, underbuck to meet the first cut and avoid pinching.

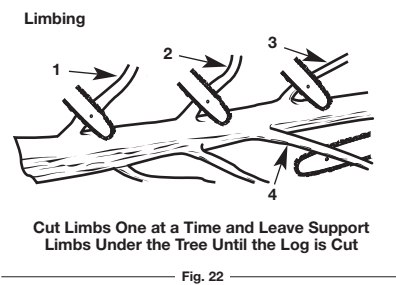

## Bucking Fully Supported Logs

When the log is supported along the entire length, cut from the top (overbuck), being careful to avoid cutting into the ground (Fig. 25).

## Overbuck

Begin on the top side of the log with the bottom of the saw against the log; exert light pressure downward. During overbucking, the saw will tend to pull away. Be prepared for this reaction and hold the saw firmly to maintain control. (Fig. 25)

## Underbuck

Begin on the under side of the log with the top of the saw against the log; exert light pressure upward. During underbucking, the saw will tend to push back. Be prepared for this reaction and hold the saw firmly to maintain control. (Fig. 26)

## Bucking with a Wedge

If the wood diameter is large enough to insert a soft wooden or plastic bucking wedge without touching the chain, one should be used to hold the cut open to prevent pinching. (Fig. 27)

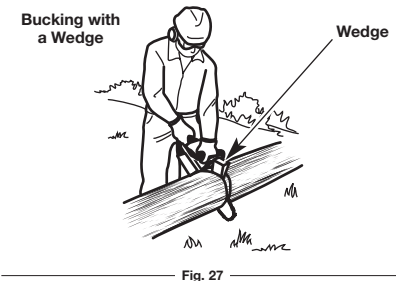
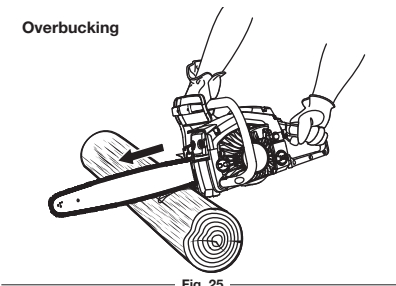
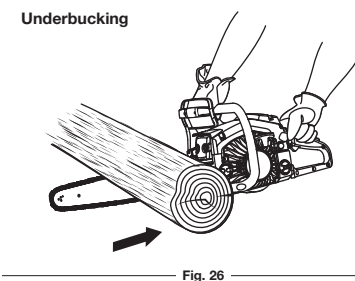
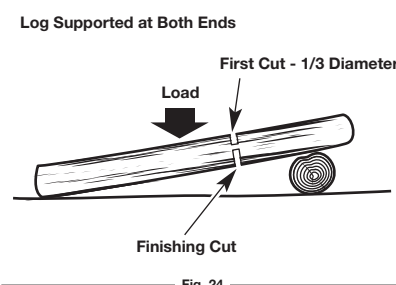
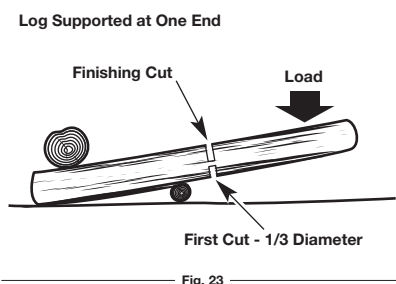

## OPERATING INSTRUCTIONS

### PRUNING

**WARNING:** If the limbs to be pruned are above chest height, hire a professional to perform the pruning.

**WARNING:** Use caution when pruning heavy branches. Falling branches can cause serious injury. Always wear head protection, plan a safe exit from the path of falling limbs and stay alert.

Pruning is the process of trimming limbs from a live tree (Fig. 28).

- Work slowly, while maintaining a proper grip and stance.
- Do not cut from a ladder; this is extremely dangerous. Leave this operation for professionals.
- Do not cut above chest height, as a saw held higher is difficult to control during kickback.
- When pruning trees it is important not to make the finishing cut next to the main limb or trunk until the limb is cut further out to reduce the weight. This prevents stripping the bark from the main member.

1. Underbuck the branch 1/3 through for the first cut.
2. The second cut should overbuck to drop the branch off.
3. Make the finishing cut smoothly and neatly against the main member so the bark will grow back to seal the wound.

### CUTTING SPRINGPOLES

**WARNING:** Watch for springpoles; these can strike the operator, causing serious personal injury.

A springpole is any log, branch, rooted stump, or sapling that is bent under tension by other wood so that it springs back if the wood holding it is cut or removed (Fig. 29). On a fallen tree, a rooted stump has a high potential of springing back to the upright position during the bucking cut to separate the log from the stump.

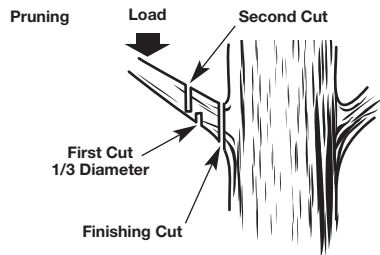

Fig. 28

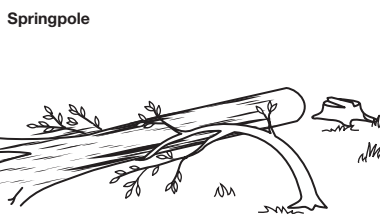

Fig. 29

## MAINTENANCE AND REPAIR INSTRUCTIONS

**WARNING:** Before inspecting, cleaning or servicing the unit, stop the engine, wait for all moving parts to stop, allow the unit to cool, disengage the chain brake and disconnect the spark plug wire to ensure that the unit cannot start. Failure to follow these instructions can result in serious personal injury or property damage.

### MAINTENANCE SCHEDULE

Perform these required maintenance procedures at the frequency stated in the table. These procedures should also be a part of any seasonal tune-up.

**NOTE:** Some maintenance procedures may require special tools or skills. If you are unsure about these procedures, take your unit to any non-road engine repair establishment, individual or authorized service dealer.

**NOTE:** Maintenance, replacement or repair of the emission control devices and system may be performed by any non-road engine repair establishment, individual or authorized service dealer.

**NOTE:** Please read the California/EPA statement that came with the unit for a complete listing of terms and coverage for the emissions control devices, such as the spark arrestor, muffler, carburetor, etc.

A good preventive maintenance program of regular inspection and care will increase the life and improve performance of the unit. This maintenance checklist is a guide for such a program.

Cleaning, adjusting and part replacement may be required, under certain conditions, at more frequent intervals than those indicated.

## CUSTOMER RESPONSIBILITY

MAINTENANCE CHECKLIST				
ACTION	BEFORE EACH USE	AFTER EACH USE	AFTER EVERY 10 HOURS OF OPERATION	AFTER EVERY 20 HOURS OF OPERATION
Check for loose screws/nuts/bolts and tighten as needed	✓			
Clean the air filter (replace when necessary)	✓			
Inspect and clean the spark plug (replace when necessary)			✓	
Inspect and clean the spark arrestor screen and muffler				✓
Check the bar lube reservoir level (refill frequently)	✓			
Inspect fuel hoses*	✓			
Inspect the chain brake components*	✓			
Clean the unit and inspect decals		✓		
Clean the guide bar groove and oil passages			✓	
Clean the cylinder fins			✓	
Check for damaged or worn parts	✓			
Check the chain tension (adjust as needed)	✓			
Check the sharpness of the chain	✓			
Lubricate the sprocket tip			✓	
Check the fuel mixture	✓			

\*If maintenance or replacement are required, have the unit serviced by an authorized service dealer.

## MAINTENANCE AND REPAIR INSTRUCTIONS

**WARNING:** To avoid possible serious injury, never touch or adjust the chain while the engine is running. The saw chain is very sharp; always wear protective gloves when performing maintenance on the chain.

**CAUTION:** A chain tensioned while warm, may be too tight upon cooling. Check the "cold tension" before next use.

### ADJUSTING THE CHAIN TENSION

The chain must be tensioned whenever the flats on the drive links hang out of the bar groove (Fig. 30). Check for proper chain tension before starting the unit and periodically during operation.

**NOTE:** A new chain tends to stretch. Check the chain tension frequently and tighten as required.

1. Stop the engine, wait for all moving parts to stop, allow the unit to cool, disconnect the spark plug wire and disengage the chain brake.
2. Slightly loosen the bar-retaining nuts (Fig. 31).
3. Hold the guide bar tip up and rotate the chain-tensioning screw (Fig. 32) clockwise with a standard screwdriver to tension the chain. The desired tension depends on the temperature of the chain:

- **Cold Chain Tensioning** - A cold chain is correctly tensioned when there is no sag on the underside of the guide bar and the chain seats snugly against the guide bar with the drive links in the bar groove.

- **Warm Chain Tensioning** - During normal operation, the temperature of the chain will increase. The drive links of a correctly tensioned warm chain will hang approximately 1/16 inch (1.3 mm) out of the bar groove (Fig. 33).

4. Once adjusted, lift the tip of the guide bar up to check for proper tension (Fig. 34). If the chain is still too loose, release the tip of the guide bar and turn the chain-tensioning screw 1/2 turn clockwise. Repeat this process until the desired tension is achieved.

**NOTE:** If the chain is too tight, it will not rotate. To loosen the chain, turn the chain-tensioning screw 1/4 turn counterclockwise. Ensure that the chain can be turned by hand without binding (Fig. 35). Also note that the chain will not rotate if the chain brake is engaged.

5. Hold the tip of the guide bar up and securely tighten the bar-retaining nuts.

### REMOVING/REPLACING THE GUIDE BAR AND CHAIN

Use only a low-kickback saw chain that has met kickback performance per ANSI B175.1 for this saw. This fast-cutting chain provides kickback reduction when properly maintained.

**NOTE:** When replacing the guide bar and chain, use only manufacturer suggested replacement parts. The use of any other parts may create a hazard or cause product damage and will VOID the warranty.

#### Removing the Old Guide Bar and Chain

1. Make sure the engine is off and the spark plug wire is disconnected. Disengage the chain brake.
2. Remove the bar-retaining nuts with the supplied multi-purpose tool. Remove the guide bar cover and guide bar plate by pulling them straight out (Fig. 31).
3. Remove the guide bar and chain from the mounting surface.
4. Remove the old chain from the guide bar.

#### Installing the New Guide Bar and Chain

1. Lay out the new saw chain in a loop and straighten any kinks. The cutters on the top of the guide bar should face toward the guide bar tip in the direction of chain rotation (Fig. 36). If they face backward, turn the loop over.

2. Place the chain drive links into the bar groove as shown (Fig. 37). **NOTE:** Make sure the chain is correctly installed and the cutters are facing in the correct direction (Fig. 36).

3. Position the chain so there is a loop at the back of the guide bar.
4. Hold the chain in position on the guide bar and place the loop around the drive sprocket.
5. Fit the guide bar flush against the mounting surface so that the two guide bar bolts are in the guide bar slot (Fig. 31).

**NOTE:** Make sure that the chain-tensioning pin is in the chain-tensioning pin hole (Fig. 38).

6. Replace the guide bar plate so that the bent edges (top and bottom) are directed away from the chain.
7. Replace the guide bar cover and bar-retaining nuts. Tighten the bar-retaining nuts hand tight.

**NOTE:** Do not over-tighten the bar-retaining nuts. The guide bar should still be free to move for chain tension adjustment.

8. Adjust the chain tension. Refer to the *Adjusting the Chain Tension* instructions above.

### ADJUSTING THE AUTOMATIC OILER

The oiler automatically delivers the proper amount of oil to the guide bar and saw chain. As the engine speed increases, so does the oil flow. The amount of oil flowing to the guide bar and saw chain may be changed by turning the adjustment screw with a small standard screwdriver. Turn the screw clockwise to decrease oil flow or turn the screw counterclockwise to increase oil flow (Fig. 39).

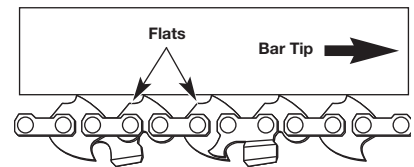

Fig. 30

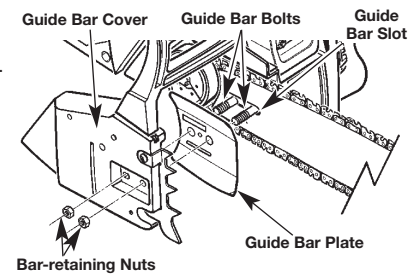

Fig. 31

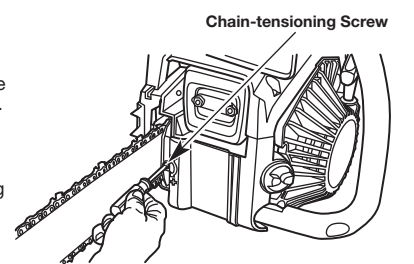

Fig. 32

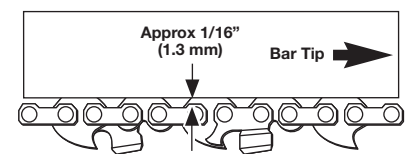

Fig. 33

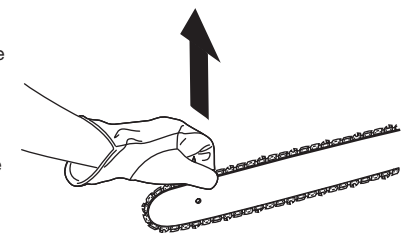

Fig. 34

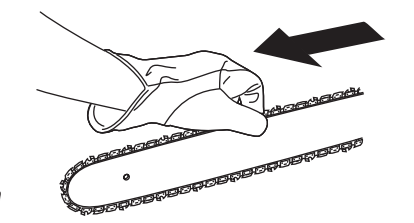

Fig. 35

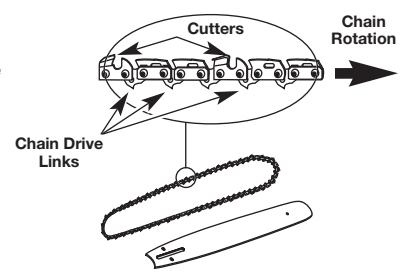

Fig. 36

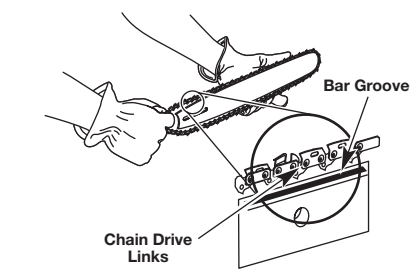

Fig. 37

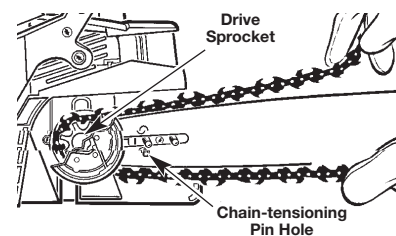

Fig. 38

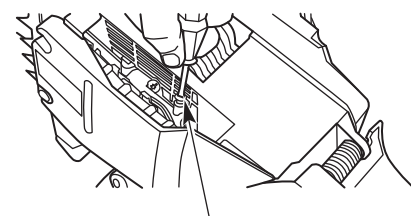

Fig. 39

**CHAIN MAINTENANCE**

For smooth and fast cutting, the chain needs to be maintained properly. The following conditions indicate that the chain requires sharpening:

- Wood chips are small and powdery.
- The chain must be forced through the wood during cutting.
- The chain cuts to one side.

During maintenance of the chain, consider the following:

- The depth gauge (or raker clearance) setting determines the height at which the cutter enters the wood and the size of the wood chip that is removed (Fig. 40). Too much clearance increases the potential for kickback. Too little clearance decreases the size of the wood chip, thus decreasing the chain's cutting ability.
- If the cutter teeth have hit hard objects, such as nails and stones, or were abraded by mud or sand on the wood, have a service dealer sharpen the chain.

**NOTE:** Inspect the drive sprocket for wear or damage when replacing the chain. If signs of wear or damage are present in the areas indicated, have the drive sprocket replaced by an authorized service center.

**NOTE:** If you do not fully understand the correct procedure for sharpening the cutters after reading the instructions that follow, have the saw chain sharpened by an authorized service center or replace the chain with a recommended low-kickback chain.

**SHARPENING THE CUTTERS**

**WARNING:** A dull or improperly sharpened chain can cause excessive engine speed during cutting, which may result in severe engine damage.

**WARNING:** Improper chain sharpening increases the potential of kickback. Failure to replace or repair a damaged chain can cause serious injury.

Be careful to file all cutters to the specified angles and to the same length. Fast cutting can be obtained only when all cutters are uniform.

- Tighten the chain tension enough so that the chain does not wobble. Do all of the filing at the midpoint of the guide bar. Wear gloves for protection.
- Use a 3/16" round file and holder.
- Keep the file level with the top plate of the tooth (Fig. 41). Do not let the file dip or rock (Fig. 42).
- Using light but firm pressure, stroke towards the front corner of the tooth (Fig. 42). Lift the file away from the cutter before returning the file to the beginning of the sharpening stroke.
- Put a few firm strokes on every tooth. File all left hand cutters in one direction (Fig. 43). Then move to the other side and file the right hand cutters in the opposite direction (Fig. 43). Occasionally remove filings from the file with a wire brush.

**Top Plate Filing Angle**

- **CORRECT (30°)** – File holders are marked with guide marks to align the file properly and produce the correct top plate angle (Fig. 44).
- **INCORRECT (LESS THAN 30°)** – For cross cutting (Fig. 45).
- **INCORRECT (MORE THAN 30°)** – This creates a feathered edge that dulls quickly.

**Side Plate Filing Angle**

- **CORRECT (80°)** – This is produced automatically if the correct diameter file is used in the file holder (Fig. 44).
- **INCORRECT (HOOK)** – This causes the chain to "grab" and dull quickly, increasing the potential for kickback. A hook is caused by using a file with too small a diameter or a file held too low (Fig. 45).
- **INCORRECT (BACKWARD SLOPE)** – This causes a need for too much feed pressure, producing excessive wear to the guide bar and chain. A backward slope is caused by using a file with too large a diameter or a file held too high.

**MAINTAINING DEPTH GAUGE CLEARANCE**

- Maintain the depth gauge at a clearance of 1/32" (0.6 mm). Use a depth gauge tool for checking the depth gauge clearances. (Fig. 40)
- Every time the chain is filed, check the depth gauge clearance.
- Use a flat file and a depth gauge jointer to lower all gauges uniformly (Fig. 46). Use a 1/32 inch (0.6 mm) depth gauge jointer. After lowering each depth gauge, restore the original shape by rounding the front (Fig. 47). Be careful not to damage adjoining drive links with the edge of the file.
- Depth gauges must be adjusted with the flat file in the same direction the adjoining cutter was filed with the round file.
- Use care not to contact the cutter face with the flat file when adjusting depth gauges.

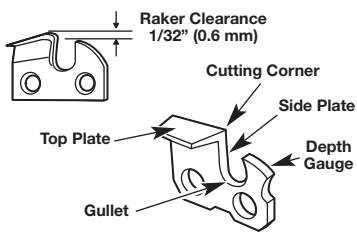

Fig. 40

**Filing Height**

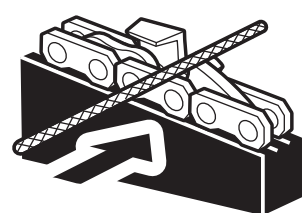

Fig. 41

**Filing Angle**

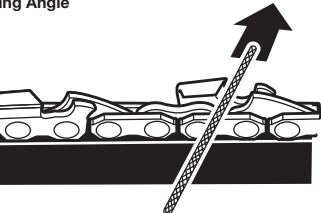

Fig. 42

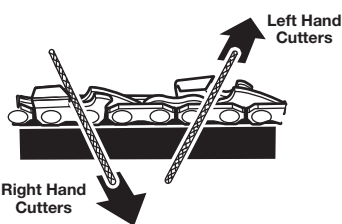

Fig. 43

**Correct Filing Angles**

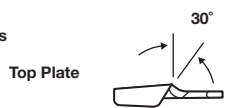

Fig. 44

**Incorrect Filing Angles**

Less Than 30°      More Than 30°

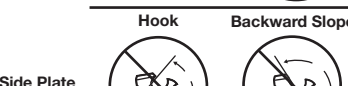

Fig. 45

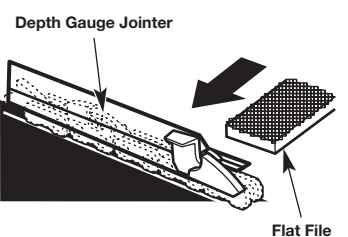

Fig. 46

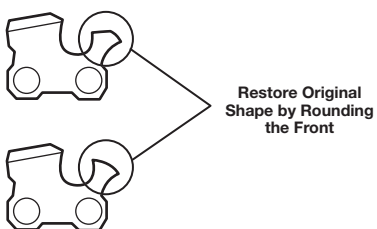

Fig. 47

**MAINTAINING THE GUIDE BAR**

To minimize guide bar wear, the following maintenance procedures are recommended:

- Rotate the guide bar frequently at regular intervals (for example, after every 5 hours of operation), to ensure even wear on the top and bottom of the guide bar (Fig. 48).
- Clean the guide bar groove and oil passages whenever the saw chain is removed, when the unit has been used heavily or when the saw chain appears dirty (Fig. 49). Oil passages can be cleaned with a soft wire small enough to insert into the oil discharge hole (Fig. 49).

**NOTE:** If the oil passages are clear, the saw chain will give off a spray of oil within seconds of starting the unit.

Frequently check the guide bar for damage. Feathering and burring of the guide bar rails (the ridges on either side of the bar groove) is a normal process of guide bar wear. Such faults should be smoothed with a file as soon as they occur.

A guide bar with the following faults should be replaced:

- Wear inside the guide bar rails that permits the chain to lay sideways.
- Bent guide bar.
- Cracked or broken rails.
- Spread rails.

**Lubricating the Guide Bar Sprocket Tip**

**CAUTION:** The guide bar sprocket tip was pre-lubricated at the factory. Lubrication of the guide bar sprocket tip is recommended after every 10 hours of operation or once per week, whichever comes first. Always thoroughly clean the guide bar sprocket tip before lubrication. Failure to lubricate the guide bar sprocket tip as explained below will result in poor performance and seizure, voiding the warranty.

**NOTE:** It is not necessary to remove the saw chain to lubricate the guide bar sprocket tip.

1. Clean the guide bar sprocket tip.
2. Insert the tip of the lube gun (not included) into the lubrication hole and inject grease until it appears at the outer edge of the guide bar sprocket tip (Fig. 50).

**NOTE:** The lube gun is recommended for applying grease to the guide bar sprocket tip. The lube gun is equipped with a needle nose tip, which is necessary for the efficient application of grease to the guide bar sprocket tip.

3. Rotate the saw chain by hand. Repeat the lubrication procedure until the entire guide bar sprocket tip is greased.

**CLEANING THE AIR FILTER**

**CAUTION:** Never operate the unit without the air filter. Dust and dirt will be drawn into the engine and damage it. Keep the air filter clean.

1. Remove the air filter cover by loosening the cover-retaining screws (Fig. 51). The cover will lift off.
2. Remove the air filter.
3. Wash the air filter in clean, warm, soapy water. Rinse the air filter in clean, cool water. Allow the filter to air dry completely.

**NOTE:** It is advisable to have a supply of spare air filters.

4. Install the air filter and replace the air filter cover. Make sure the air filter cover fits properly. Tighten the cover-retaining screws securely.

**CLEANING THE SPARK ARRESTOR SCREEN**

**NOTE:** A clogged spark arrestor screen will dramatically reduce engine performance.

1. Locate the muffler assembly at the front of the unit. Use a small flat-blade screwdriver to remove the two plugs from the muffler assembly.
2. Use a T27 Torx wrench to remove the two muffler-retaining screws (Fig. 52).
3. Remove the muffler assembly and gasket from the unit.
4. Use the multi-purpose tool or a #2 Phillips screwdriver to remove the deflector-retaining screw.
5. Remove the outer deflector and spark arrestor screen.
6. Use a small wire brush to remove debris from the spark arrestor screen.
7. Reconnect the spark arrestor screen and outer deflector to the muffler assembly. Make sure the two tabs on the outer deflector are inserted into the two slots on the muffler assembly. Tighten the deflector-retaining screw securely.
8. Insert the two muffler-retaining screws into the muffler assembly. Place the gasket behind the muffler assembly so that the two muffler-retaining screws pass through the two holes in the gasket. Make sure the narrow end of the gasket faces the bottom of the muffler assembly (Fig. 52). Insert the muffler assembly and gasket into the cavity at the front of the unit so that the screws align with the two screw holes in the front cavity. Tighten the muffler-retaining screws securely to a torque of 80-90 in.lbs. If necessary, hold the gasket from the side with a pair of needle-nose pliers while tightening the screws. If assistance is required for achieving the proper torque, have the unit serviced by an authorized service dealer.
9. Insert the two plugs into the muffler assembly. With a blunt tool, lightly tap the plugs firmly into place.

**NOTE:** Do not operate the unit without the plugs securely installed.

**INSPECTING/ADJUSTING/REPLACING THE SPARK PLUG**

**NOTE:** For efficient operation, the spark plug must be kept clean and properly gapped.

**WARNING:** Do not sand blast, scrape or clean spark plug electrodes. Dislodged grit could damage the cylinder. Replace corroded spark plugs.

1. Push the stop switch up to the STOP position.
2. Use the multi-purpose tool to remove the two retaining screws from the top plate (Fig. 53). Remove the top plate.
3. Disconnect the wire connector from the spark plug by pulling and twisting at the same time (Fig. 53).
4. Remove the spark plug with a spark plug socket wrench. **DO NOT USE ANY OTHER TOOL.**
5. Check the electrode gaps with a wire feeler gauge. The gap should be set to 0.025 in. (0.635 mm). Adjust the gaps if necessary.
6. Reinstall the correctly gapped spark plug or, if needed, install a new spark plug (Champion® RDJ8J or equivalent).

**NOTE:** A resistor spark plug must be used for replacement (part number 753-06269 or Champion® RDJ8J).

**CARBURETOR ADJUSTMENT**

The carburetor was pre-set at the factory for optimum performance. If further adjustments are necessary, please have the unit serviced by an authorized service dealer.

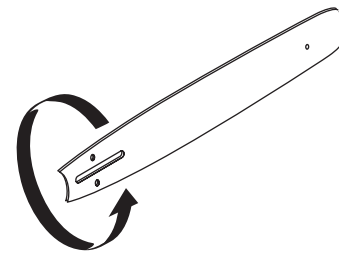

Fig. 48

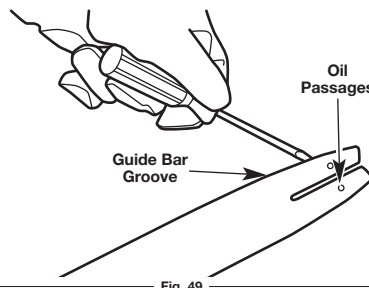

Fig. 49

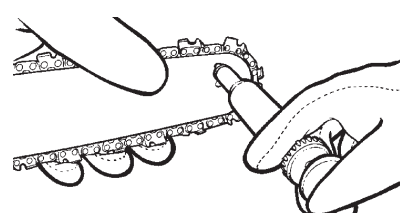

Fig. 50

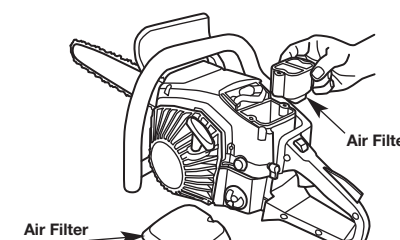

Fig. 51

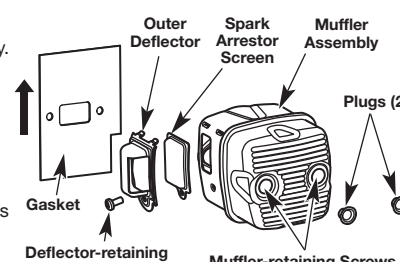

Fig. 52

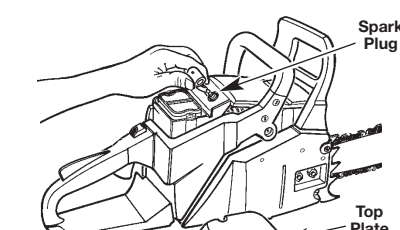

Fig. 53

## CLEANING AND STORAGE



**WARNING:** Do not let brake fluids, gasoline, petroleum-based products, penetrating oils, etc., come in contact with plastic parts. These chemicals may damage, weaken and destroy plastic, which may result in serious personal injury.

### CLEANING INSTRUCTIONS

1. Stop the engine and wait for all moving parts to stop.
2. Allow the unit to cool.
3. Slacken the chain if it was retensioned at operating temperature during cutting work. The chain contracts as it cools down. If it is not slackened, it may damage the gearbox and bearings.
4. Wipe the unit down with a damp cloth. Do not douse the unit with water. Do not use solvents or strong detergents. If preparing the unit for long-term storage (three months or more), remove the chain and guide bar, then clean the unit thoroughly with a damp cloth. A firm-bristled, non-wire, brush can be used to remove debris from the bar groove and assembly. When finished, reassemble the unit. Refer to *Removing/Replacing the Guide Bar and Chain*.

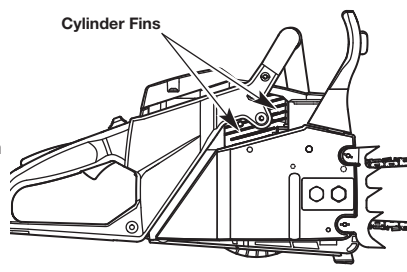

5. Debris must be removed from the cylinder fins on a regular basis to reduce the risk of damage to the unit and personal injury from fire. Use compressed air, at 40 PSI or lower, to blow debris from the cylinder fins (Fig. 54). Always wear safety goggles/glasses when cleaning the cylinder fins with compressed air. Use a small wire brush to dislodge stubborn debris. Do not use water or solvents on the cylinder fins. If there is a significant amount of debris that remains after cleaning, have the cylinder fins cleaned by an authorized service dealer.
6. Spray the guide bar and chain with corrosion inhibiting oil.

### STORAGE INSTRUCTIONS

**NOTE:** It is normal for oil to seep from the unit when it is not in use. Please take this into consideration when storing the unit.

1. Follow the *Cleaning Instructions* listed above.
2. Attach the scabbard to the guide bar and chain.
3. Store the unit in a dry, high and/or locked location, out of the reach of children and other unauthorized persons. Always store the unit and fuel in a cool, well-ventilated space where fuel vapors cannot reach sparks or open flames from water heaters, electric motors or switches, furnaces, etc. Never store the unit, with fuel in the tank, inside a building where fumes may reach an open flame or spark.

### Long-term Storage Instructions

In addition to the standard storage instructions described above, perform the following steps when storing the unit for 30 days or more:

1. Drain the fuel tank by running the unit dry. Alternatively, tip the engine housing/fuel tank over to pour the fuel mixture into a suitable container and then run the engine until it stops in order to remove fuel from the carburetor.
2. Allow the engine to cool.
3. Remove the spark plug. Refer to *Inspecting/Adjusting/Replacing the Spark Plug*.
4. Pour 1 teaspoon of clean 2-cycle oil into the combustion chamber (Fig. 55). Pull the starter rope slowly several times to coat the internal components.
5. Replace the spark plug.

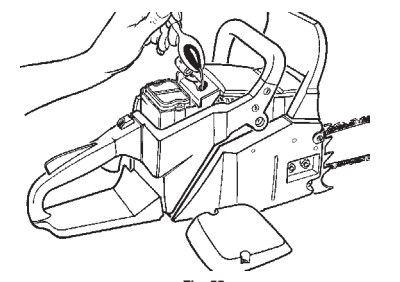

### Removing a Unit From Long-term Storage

1. Remove the spark plug.
2. Pull the starter rope briskly to clear excess oil from the combustion chamber.
3. Clean and gap, or replace, the spark plug.
4. Prepare the unit for operation.

## TROUBLESHOOTING

CAUSE	SOLUTION
<b>THE UNIT WILL NOT START OR STARTS BUT DOES NOT CONTINUE TO RUN</b>	
The unit was started incorrectly	Follow all <i>Starting and Stopping Instructions</i>
The carburetor mixture adjustment setting is incorrect	Have the carburetor adjusted by an authorized service center
The spark plug is fouled	Clean, gap or replace the spark plug
The fuel tank is empty	Fill the fuel tank with properly mixed fuel
The primer bulb was not pressed enough	Press the primer bulb fully and slowly 10 times
<b>THE UNIT STARTS, BUT THE ENGINE HAS LOW POWER</b>	
The fuel filter is plugged	Have the fuel filter cleaned or replaced by an authorized service center
The choke lever is in the wrong position	Move the choke lever to Position 2
The spark arrestor screen is dirty	Clean the spark arrestor screen
The air filter is dirty	Clean the air filter
The carburetor mixture adjustment setting is incorrect	Have the carburetor adjusted by an authorized service center
<b>THE ENGINE HESITATES</b>	
The carburetor mixture adjustment setting is incorrect	Have the carburetor adjusted by an authorized service center
The air filter is plugged	Clean or replace the air filter
The fuel is old and/or improperly mixed	Drain the fuel tank and add fresh, properly mixed fuel
<b>THERE IS NO POWER WHEN THE UNIT IS UNDER LOAD</b>	
The carburetor mixture adjustment setting is incorrect	Have the carburetor adjusted by an authorized service center
The fuel is old and/or improperly mixed	Drain the fuel tank and add fresh, properly mixed fuel
The air filter is plugged	Clean or replace the air filter
The spark plug is fouled	Clean, gap or replace the spark plug
<b>THE ENGINE RUNS ERRATICALLY</b>	
The spark plug is incorrectly gapped	Clean, gap or replace the spark plug
The spark arrestor screen is plugged	Clean the spark arrestor screen
The air filter is dirty	Clean or replace the air filter
<b>THE ENGINE SMOKES EXCESSIVELY</b>	
The carburetor mixture adjustment setting is incorrect	Have the carburetor adjusted by an authorized service center
The fuel mixture is incorrect	Drain the fuel tank and add fresh, properly mixed fuel
<b>THE GUIDE BAR AND CHAIN ARE RUNNING HOT AND SMOKING OR STUCK</b>	
The chain tension is too tight	Adjust the chain tension
The bar lube reservoir is empty	Refill the bar lube reservoir
The guide bar groove and/or oil passages are dirty	Clean the guide bar groove and oil passages
The oil flow from the automatic oiler is low	Increase the oil flow from the automatic oiler
<b>THE CHAIN DOES NOT ROTATE WHILE THE ENGINE IS RUNNING</b>	
The chain tension is too tight	Adjust the chain tension
The guide bar and chain are assembled incorrectly	Refer to <i>Removing/Replacing the Guide Bar and Chain</i>
The guide bar and chain are damaged	Inspect the guide bar and chain for damage
The drive assembly is damaged	Refer to <i>Service Information</i>
The chain brake is engaged	Disengage the chain brake
<b>THE CHAIN ROTATES, BUT DOES NOT CUT</b>	
The chain is dull	Sharpen the chain
The chain is on backwards	Reverse the direction of the chain

**NOTE:** For repairs beyond the minor adjustments listed above, locate your nearest authorized service center by calling the Customer Support Department at 1-877-282-8684 (U.S.) or 1-800-668-1238 (Canada).

## SPECIFICATIONS\*

Engine Type	Air-Cooled, 2-Cycle
Displacement	51 cc (3.11 cu in)
Idle Speed	2,800 rpm
Operating Speed	8,500 rpm
Ignition Type	Electronic
Ignition Switch	Slide Switch
Starter	AST Starting Auto Rewind
Throttle Control	Finger-Tip Trigger
Throttle	Manual Spring Return
Spark Plug Gap	0.025 in (0.635 mm)
Carburetor	Diaphragm, All-Position
Muffler	Baffled with Guard
Drive Sprocket	6-Tooth
Lubrication	Bar and Chain Oil
Bar Lube Reservoir Capacity	15 fl oz (443 ml)
Fuel/Oil Ratio	40:1
Fuel Tank Capacity	18 fl oz (532 ml)
Cutting Diameter	36 in (91.4 cm)
Bar Length	18 in (45.7 cm)
Chain Pitch	.325 in (8.2 mm)
Chain Gauge	0.05 in (1.27 mm)
Approximate Unit Weight (no fuel)	17.5 lbs (7.9 kg)

\* All specifications are based on the latest product information available at the time of printing. We reserve the right to make changes at any time without notice.

### REPLACEMENT PARTS

Part #	Description
753-06265	18-inch Chain
753-06264	18-inch Guide Bar
753-06270	Bar Lube Reservoir Cap
753-06271	Bar-retaining Nuts
753-06272	8 oz Bar and Chain Oil