

Model 60 Alton Optimum 5.0 Series



- Social/Prep Sink
- Undermount
- Includes Mounting Clips and Template
- Requires Deck Mount Faucet

20" x 20" x 8"

508mm x 508mm x 203.2mm

Cutout dimensions: Due to variations in desired reveal, it is highly recommended that the actual sink be provided to the countertop fabricator prior to making any cuts.

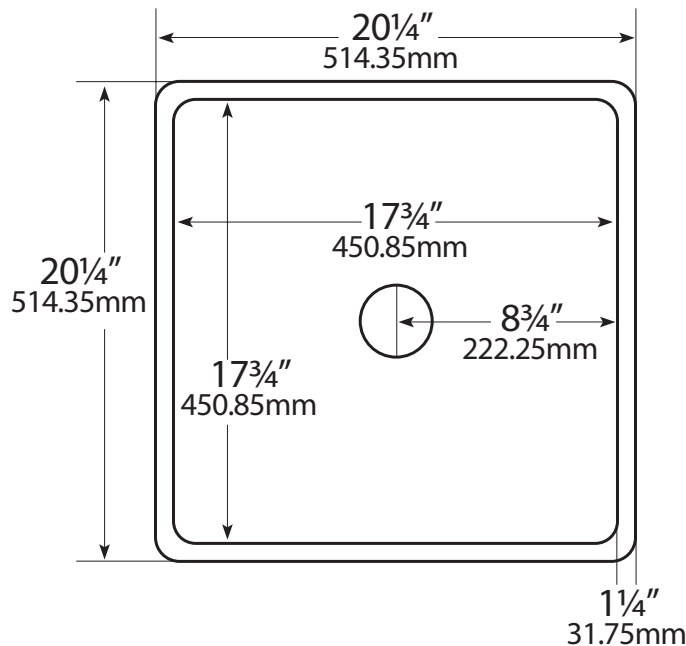

Drains not included.



Certified by: National Association of Homebuilders
(NAHB) Research Center and CSA International

Meets or Exceeds:

CSA B45.0-02 ANSI Z 124.3 - 1995
CSA B45.5-02 ANSI Z 124.6 - 1997

All designs and specifications
subject to change without notice
All dimensions are $\pm 1/4$ " (6.35 mm)

United States Patents US437,035, US441,853, US442,679, US453,554, US457,944 and other Patents Pending may apply.

900051 © 2009 CorStone, Inc.