

TECHNICAL SPECIFICATIONS

Rough: 4 Pc. Roman Tub – 3/4" valves

289 745

Rough# | 289 745 999

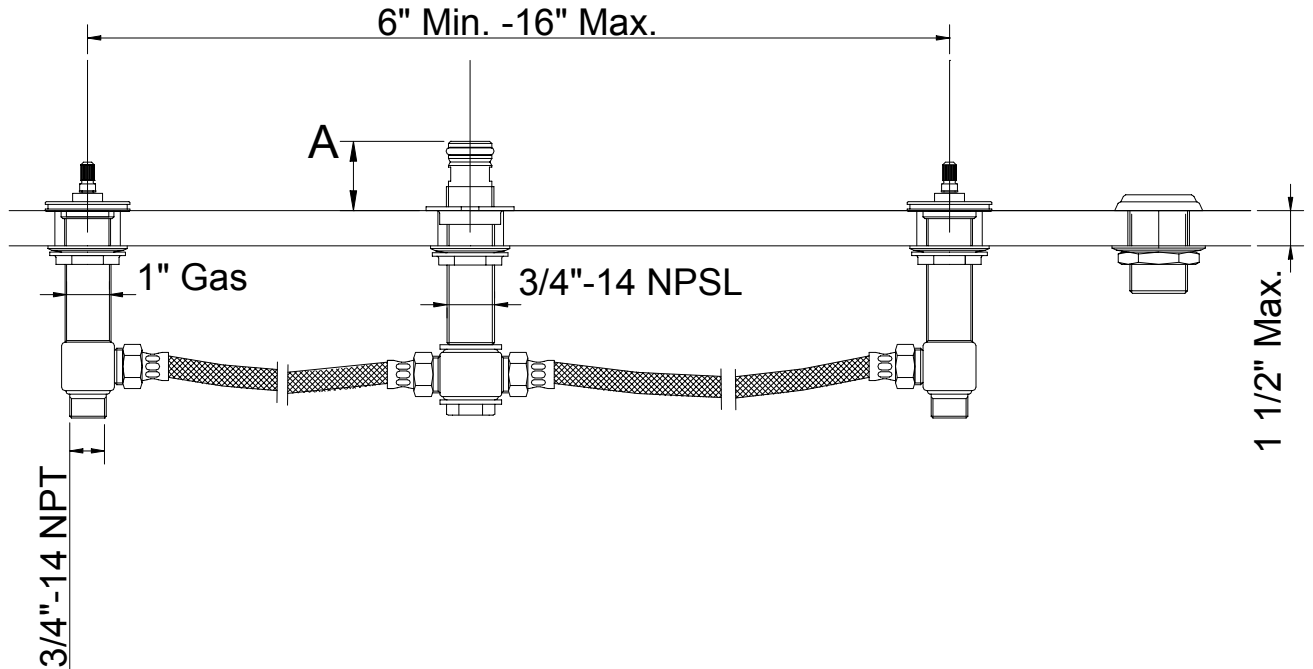

Recommended Hole Diameters: Nipple – 1 1/4"
Valves – 1 1/2"
Handshower – 1 1/2"

Valve: 3/4" Ceramic disc valve cartridge. 1,000,000 Tested cycles.
1/4 Turn positive on/off.
Non-rising spindle

Pressure: Maximum (tested); 200 psi (14.1kg/cm²).
Recommended (flowing); 15-75 psi (1.1-5.3 kg/cm²).

Trim & Rough sold separately

Attention Installer:

To ensure a proper seal, the top of the brass spout nipple must be installed at the following dimension above the finish deck, based on trim set to be used (see table)
If finish deck thickness is unknown at rough-in, leave access to valves and tee to allow adjustments.

Flow rates: 30 gpm @ 60 psi

Maximum Deck Thickness: 1 1/2"

Inlets: 3/4" NPT

	Rough in dimensions (from top of finished deck)
	A
Asbury Trim	1 1/8" (± 1/16")
Countryside Trim	1 1/8" (± 1/16")
Envision Trim	1 5/16" (± 1/16")

2935 Amwiler Road
Atlanta, GA 30360-6001



Phone: 800.528.4904
Fax: 800.528.1969

TECHNICAL SPECIFICATIONS

Rough: 4 Pc. Roman Tub – 3/4" valves

289 745

Service Parts

Rough# | 289 745 999

1	Nipple assembly	
1.1	O-ring 20x3.53	
1.2	Nipple	
1.3	Spider nut 3/4" NPSL	
1.4	Rubber washer 45x33x1	
1.5	Washer	
1.6	Mounting nut 3/4" NPSL	
2	Tee assembly	
2.1	Washer	
2.2	O-ring 22x5	
2.3	Tee	
2.4	Locknut	
3	Washer	
4	Locknut 1"	
5	Complete 3/4" x 1/4" turn side valve	
5.1	Valve body	
5.2	3/4" Nut	
5.3	Washer	
5.4	3/4"x1/4" turn ceramic cartridge	
5.5	O-ring 40x2	
5.6	3/4" Locknut	
6	3/4" Female x 3/4" female flexible hose	
7	3/4" Self position locknut	
8	Bracket assembly	
8.1	Bracket	
8.2	Rubber washer	
8.3	Locknut	

