

CAL-ROYAL

INSTRUCTIONS FOR INSTALLING SL SERIES LEVER HANDLE SETS.

PRODUCTS, INC.
* THRU BOLTS ARE PROVIDED AND RECOMMENDED FOR USE ON HIGH FREQUENCY DOORS.

SL SERIES ARE PACKED UNASSEMBLED INSIDE BOX FOR CONVENIENCE & QUICK INSTALLATION.

Must use #10-32UNF x 9/32" if thru bolts not installed. Must use #10-32UNF x 1 1/8" (packed with convertible thru bolt) in installing convertible thru bolt.

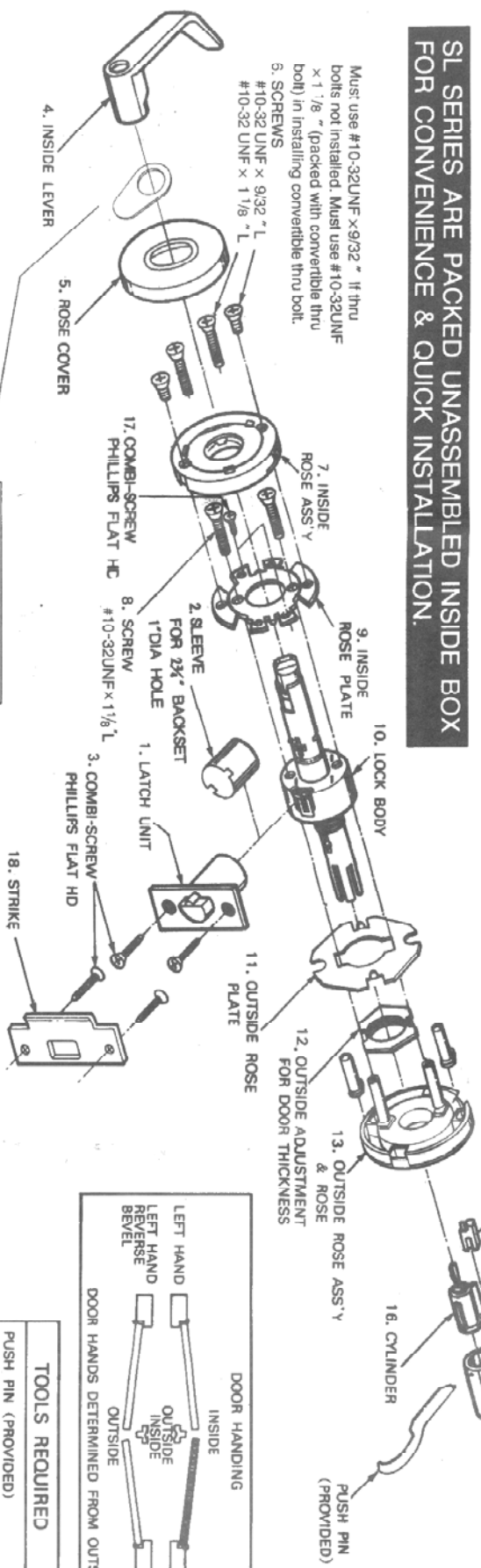

The anti-sagging mechanism of handle in SL lever handle set has a patent pending in the U.S. and foreign countries. (U.S. Patent No. 5265924)

REMOVE WHITE PAPER SPACER BEFORE INSTALLING INSIDE LEVER.

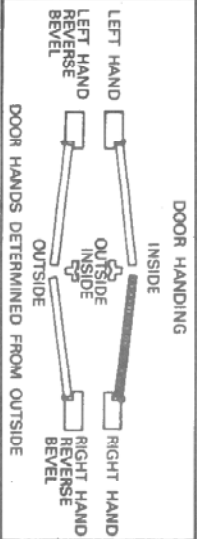

- TOOLS REQUIRED**
- PUSH PIN (PROVIDED)
 - NO. 2 PHILLIPS SCREWDRIVER
 - 1/8-INCH DRILL BIT
 - 5/16-INCH DRILL BIT

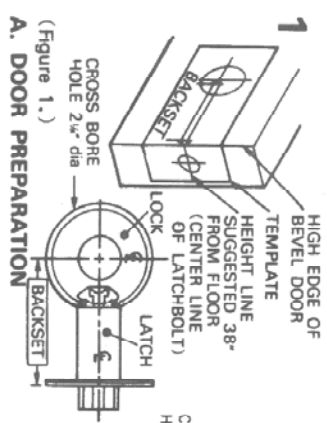

A. DOOR PREPARATION
(Figure 1.)
1. Check lock for proper backset and body outside stud bolt type before drilling.
2. Place paper template (supplied) on door and mark for holes. Drill the cross-bore hole, and then the latch hole.
NOTE
Put in notches on 2 1/4" cross-bore hole for seal door. (Refer to fig. 2.)

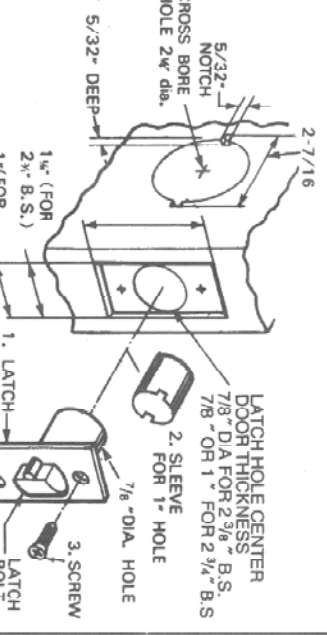

B. DOOR PREPARATION
(Figure 2.)
3. Mortise latch unit from 5/32" into door edge to dimensions shown in fig. 2.
4. Insert latch unit(1) with sleeve(2) if hole is 1" dia. or without sleeve into 7/8" dia.
5. Drill two 9/64" dia. holes and secure latch unit with combi-screws(3) supplied.

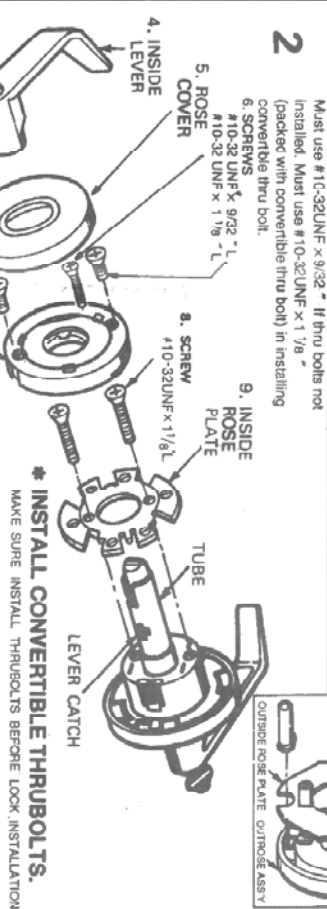

C. INSTALL CONVERTIBLE THRU BOLTS.
Must use #10-32UNF x 9/32" if thru bolts not installed. Must use #10-32UNF x 1 1/8" (packed with convertible thru bolt) in installing convertible thru bolt.
6 SCREWS
#10-32 UNF x 9/32" L
#10-32 UNF x 1 1/8" L
9. INSIDE ROSE PLATE
#10-32UNF x 1 1/8" L
TUBE
LEVER CATCH

*** INSTALL CONVERTIBLE THRU BOLTS.**
MAKE SURE INSTALL THRU BOLTS BEFORE LOCK INSTALLATION.

- Disassemble inside lever
- Disassemble inside rose ass'y
- Make clearance between outside rose plate and outside rose ass'y and insert the convertible thru bolts (provided 2 pcs additionally) into the cavities for convertible thru bolts in the outside rose ass'y
- Continue lock installation per instructions. Replace outside rose plate.

*** THRU BOLTS ARE PROVIDED AND RECOMMENDED FOR USE ON HIGH FREQUENCY DOORS.**

TEMPLATE FOR INSTALLING

MARK CENTER OF DOOR THICKNESS FOR 1" DIA. HOLE

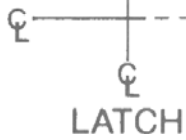

DETACH HERE

HIGH BEVEL

LOW BEVEL

FLAT NO BEVEL

HIGH BEVEL

LOW BEVEL

MARK CENTER FOR 5/16" HOLES

NOTE
DO NOT MAKE THE HOLES FOR LOCKS WITHOUT OUTSIDE STUD BOLT TYPE

MARK CENTER FOR 2 1/8" HOLE

"Notch for metal door only"

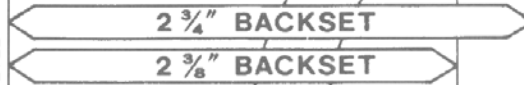

LATCH

IMPORTANT
FOR HIGHSIDE OF BEVEL PLACE OUTSIDE LINE AT EDGE OF DOOR
FOR FLAT DOORS PLACE CENTER LINE AT EDGE OF DOOR
FOR LOWSIDE OF BEVEL PLACE INSIDE LINE AT EDGE OF DOOR

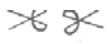
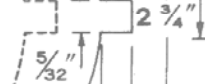

3

C. LOCK BODY ALIGNMENT & CENTERING

The lock body must engage the latch unit (1) prongs as shown. The lock body must be centered in the door jamb. Door must be opened when installing lockset with guarded latch unit.

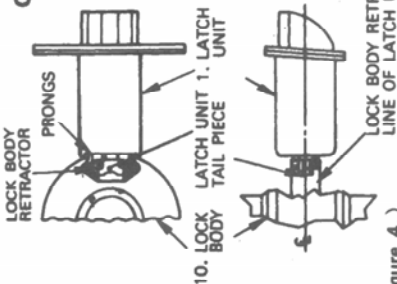

10. LOCK BODY RETRACTOR ON CENTER LINE OF LATCH UNIT TAIL PIECE (Figure 4.)

NOTE:

Be sure latch unit tail piece is centered within lock body retractor. Adjust it if necessary by outside plate (11) as shown in fig 10 and fig 11.

4

TUBE
VIEW FOR FIG. 4

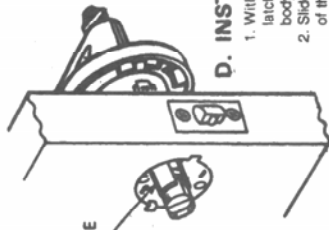

D. INSTALLATION OF LOCK UNIT

1. With finger, depress the latch, extending the latch unit tail piece to aid in engaging the lock body retractor (see fig 4)
2. Slide lock body into cross-bore hole from exterior of the door if necessary, move tail piece slightly to engage retractor as shown in fig. 4.

(Figure 5.)

5

9. INSIDE ROSE

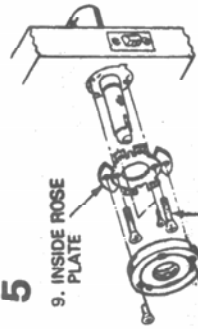

8. #10-32UNF x 1 1/8"

(Figure 6.)

E. SECURING THE LOCKSET UNIT TO DOOR.

1. Place the inside rose plate (9). Tighten it to lock body with two #10-32UNF x 1 1/8" screws (8).
2. Drill two 9/64" dia. holes and secure the rose with two combi-screws (11).

THIS MUST BE DONE TO FIRMLY ANCHOR LOCK TO DOOR

6

F. ATTACHING INSIDE ROSE ASS'Y

1. Position the inside rose ass'y's screw holes vertically with wider notch at inside diameter in line with lever catch. Then slide with tube extending into hole with #10-32UNF x 9/32" screw (6).
2. Secure inside rose ass'y to inside rose plate with two #10-32UNF x 9/32" screws (6).

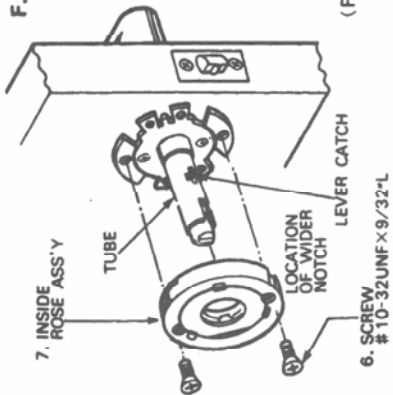

(Figure 8.)

8

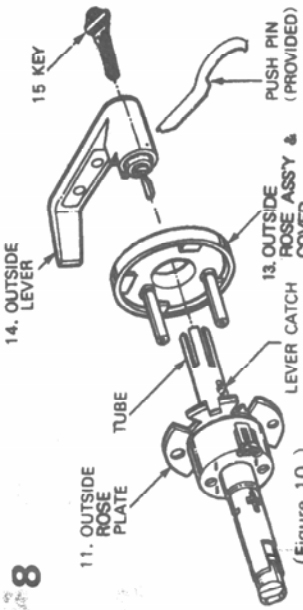

(Figure 10.)

H. TO REMOVE OUTSIDE LEVER & ROSE

1. To remove outside lever (14) insert key (15) and turn 45 clockwise. Insert push pin into hole on lever to depress lever catch. Slide the lever (14) from tube.
 2. Remove outside rose ass'y & rose (13).
- NOTE: This step must be done if you have to make adjustments for door thickness (See note in fig. 4 & fig 11.)

9

ADJUST TO 9/64" FOR 1-3/8" THICKNESS OF DOOR

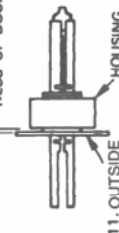

ADJUST TO 11/32" FOR 1-3/4" THICKNESS OF DOOR

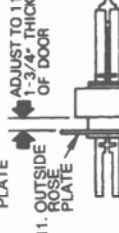

(Figure 11.)

I. ADJUSTMENT FOR DOOR THICKNESS

- It can be adjusted for door thickness range from 1 1/4" to 1 3/4". For adjustment of door thickness, follow step 8, then:
1. Adjust outside adjustment nut for proper door thickness. The outside adjustment nut post holes must be in line with holes in lock body.
 2. Slide outside rose ass'y with rose cover (13) onto tube with the wider notch at inside diameter in line with lever catch. This screw hole holes are holes for aligned between rose plate and lock body.
 3. 10. Install outside lever by reversing procedure shown in fig.

SL SERIES IS PRESET FOR 1 3/4" DOOR AT FACTORY

OUTSIDE ADJUSTMENT NUT FOR DOOR THICKNESS

10

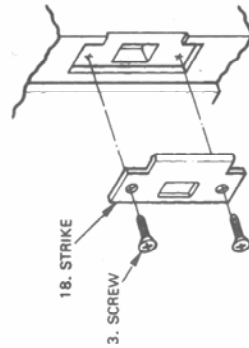

(Figure 12.)

J. INSTALLING STRIKE

When strike box (19) is not used, recess in door jamb must be deep enough to allow latch bolt to extend to its full free length.

11

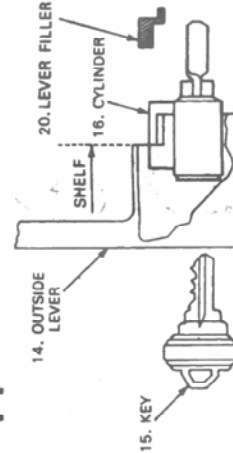

(Figure 13.)

K. CYLINDER REMOVAL & REASSEMBLY

1. Remove outside lever (14) and cylinder (16) as described in fig. 10
2. To reassemble, put a cylinder and key in lever. Push cylinder further in until it engages retractor. Turn key 90° clockwise and hold a key. Depress lever catch and push lever (not key) until it clicks. Then release a key.

HDP-0710/92

WARNING

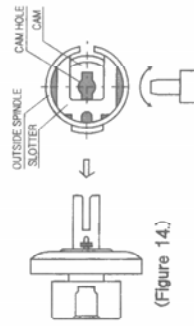

(Figure 15.)

MAKE SURE TO TURN CAM ANTI-CLOCKWISE BY DRIVER AS FAR AS IT WILL GO BEFORE REASSEMBLING OF CYLINDER TO PREVENT MIS-POSITIONING OF CAM FOR CLASSROOM FUNCTION (SEE Fig 14, Fig 15.)