

Step 2

- Remove power feed cap (J) push power feed body (K) onto track.
- Screw power feed cap (J) onto the power feed body (K).
- Insert screw driver into power feed through hole (L) on the contact screws (M) and tighten only until they make full contact.
- Each contact screw (M) must be equally offset on both sides of the track.
- Make a final turn on each contact screw (M) until the through holes are in a vertical position.

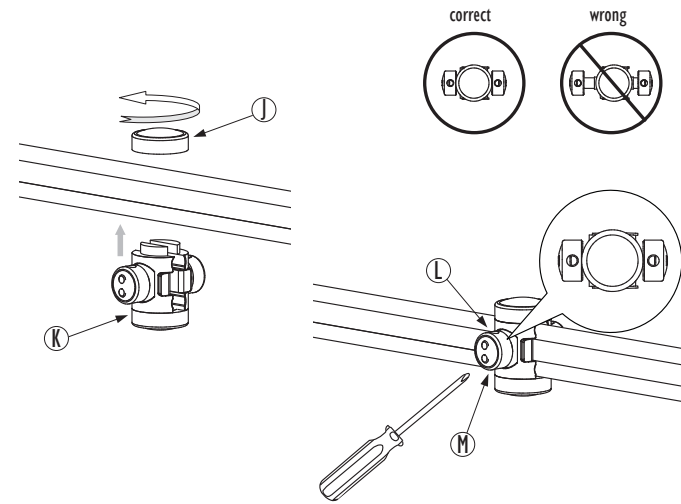

Step 3

- Insert power feed (N) into the power rods (H) and tighten the two set screws (O) on each side firmly.

CAUTION: OVERTIGHTING WILL STRIP THE THREADS ON THE POWER FEED AND CAUSE POOR CONTACT RESULTING IN OVERHEATING AND FAILURE OF SYSTEM.

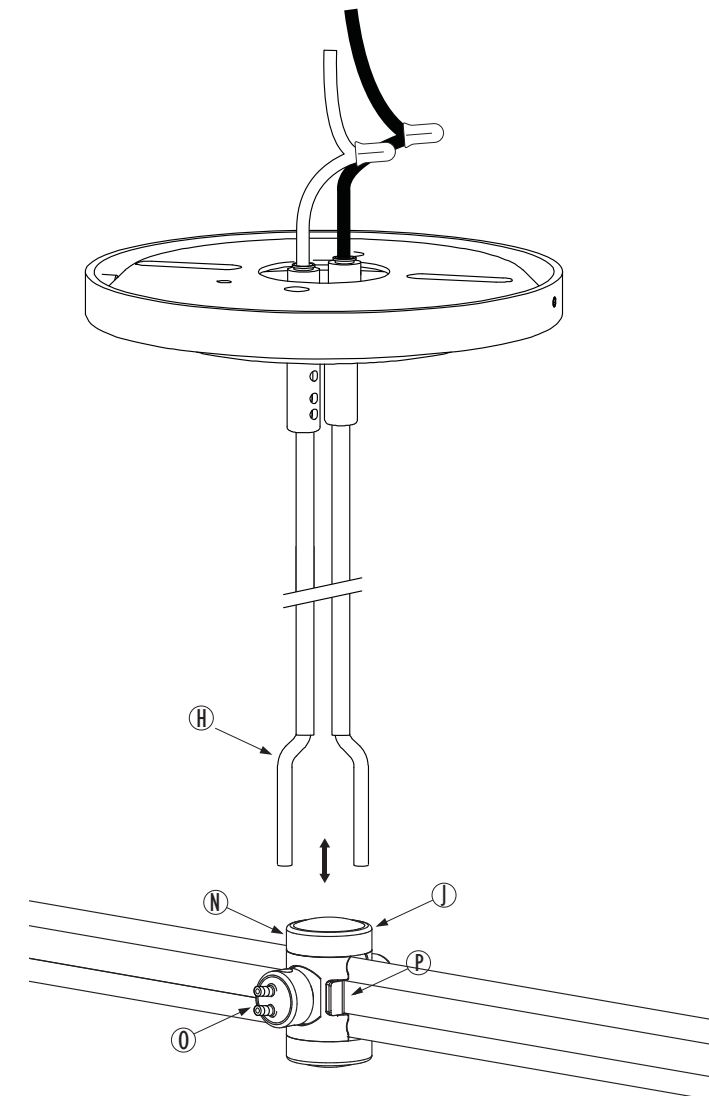

Remove Track from Power Feed

- Turn off all power.
- Loosen the set screws (O) and remove the power rods.
- Loosen the contact screws (L) on both sides
- With a flat tool, push back the contact plates (P) until it clears the track.
- Unscrew the power feed cap (J) and remove the power feed.

ENZIS

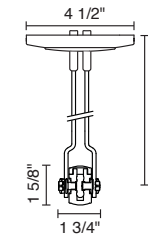

IMPORTANT SAFETY INSTRUCTIONS

1. THIS PRODUCT MUST BE INSTALLED BY A PERSON FAMILIAR WITH THE CONSTRUCTION AND OPERATION OF THE PRODUCT AND THE HAZARDS INVOLVED, IN ACCORDANCE WITH LOCAL NEC CODE.
2. FOR USE WITH ENZIS RAIL NETWORK ONLY.
3. The Enzis rail system is not intended for use with a power supply cord or convenience receptacle adaptor. This rail system is to be supplied by Bruck Lighting.
4. Do not install this rail in damp or wet locations.
5. Do not install any part of a rail system less than 5 feet above the floor.
6. Do not install any fixture assembly closer than 6 inches from any curtain, or similar combustible material.
7. Disconnect electrical power before adding to or changing the configuration of the rail.
8. Do not attempt to energize anything other than lighting rail fixtures on the rail. To reduce the risk of fire and electric shock, do not attempt to connect power tools, extension cords, appliances, and the like to the rail.
9. This track system MUST BE HARD WIRED. For all the wire connections, use Listed Wire Nuts.
10. Do not connect a rail to more than one circuit unless the rail is constructed so that it can be used with more than one circuit. Check with a qualified electrician. Although the rail lighting system may seem to operate acceptably, a dangerous overload of the neutral may occur and result in a risk of fire.
11. Secondary connections must be clean and tight to avoid arcing and overheating!
12. Power Feed must be 3 inches away from any support
13. Warranty is void in case of unauthorized modifications and/ or improper use.

READ ALL OF THESE INSTALLATION INSTRUCTIONS BEFORE INSTALLING

ENZIS CANOPY PART NUMBER

- 140 306bz bronze
- 140 306mc matte chrome

INSTALLATION INSTRUCTIONS

Step 1

- Run the power cables (A) from the transformer to the wire leads on the mounting base. Use wire nuts to connect the cable. Mount the base with screws (C).
- Place the canopy cover (D) over the mounting base (B) and secure with the two side screws (F).
- Cut the two rods (G) to the desired length. Cut off an additional 1/2" of insulation (H) on the rod so that the ends are exposed. Insert the rods into the connectors (E) and tighten all allen screws (I) securely.

