

INSTRUCTIONS

Step 1 : Installing connectors (fig. 1)

The track ends have pre-drilled holes where a connector can be installed. Star washers must be inserted to ensure conductivity between tracks.

fig. 1

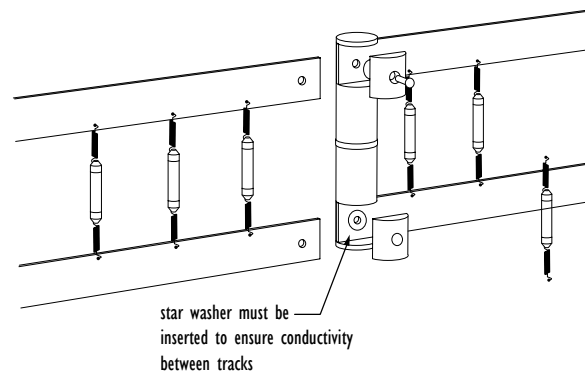

Step 2 : Mounting (fig. 2)

The supports should be spaced evenly along the ring; approximately every three feet along the track. A wood block must be used when mounting to tiled ceilings.

fig. 2

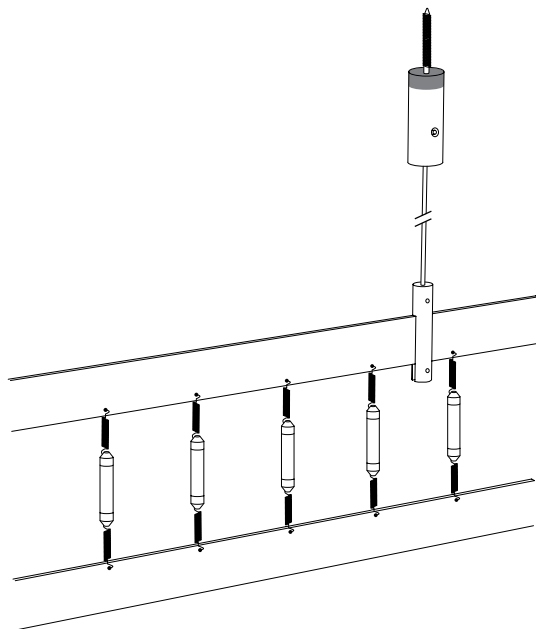

INSTRUCTIONS

Step 4 : Power Supply (fig. 3)

All Connections Must Be Tight and Clean to prevent arcing and overheating; **DAMAGE TO THE SYSTEM** will result if ignored! Transformer should be mounted no more than 15 ft. from the Flight power feeds for optimal performance*.

When turning on the system for the first time, turn off the system after 15 minutes and check ALL track and power connections for any heat. A proper connection will NOT feel significantly higher than body temperature. If connection feels warmer, re-tighten and re-check until remedied. **CAUTION** - lamps will be hot!

*TQ transformers may increase the optimal distance at which transformers can be placed; please see the documentation included with your transformer for details.

fig. 3

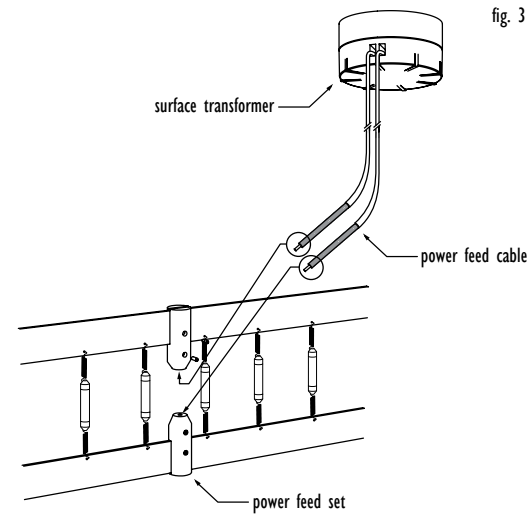

Notes : festoon lamp replacement (fig. 4)

WARNING! Turn of power prior to any work on the systems. Each 6' 6" track section draws 50W of power. The festoon lamps are held to the track with two springs. To replace the lamp unhook the festoon from the springs.

fig. 4

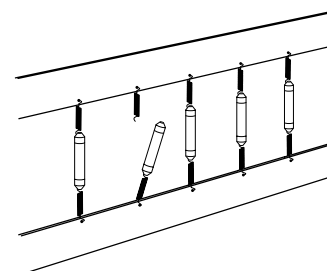

BILL OF MATERIALS

The FLIGHT RING consists of the following Bruck parts; please check for each of these items before installation. PLEASE READ all installation instructions included with the parts prior to installation.

FLIGHT TRACK
Qty. 2 x 225001

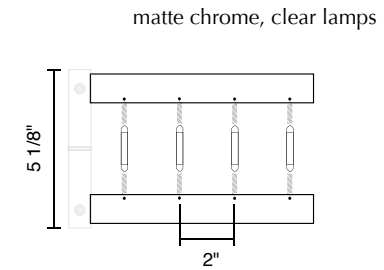

FLIGHT CONNECTOR
Qty. 2 x 225040

matte chrome, conductive

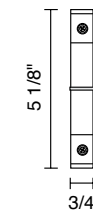

FLIGHT SUSPENSION SUPPORT V
Qty. 4 x 225020

matte chrome, vertical



FLIGHT POWER FEED
Qty. 1 x 225030

matte chrome

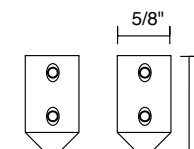

FLIGHT RING

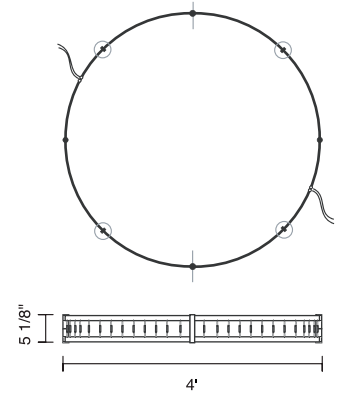

IMPORTANT SAFETY INSTRUCTIONS



1. SAVE THESE INSTRUCTIONS AND REFER TO THEM WHEN ADDITIONS TO OR CHANGES IN THE TRACK CONFIGURATION ARE MADE.
2. THIS PRODUCT MUST BE INSTALLED BY A PERSON FAMILIAR WITH THE CONSTRUCTION AND OPERATION OF THE PRODUCT AND THE HAZARDS INVOLVED, IN ACCORDANCE WITH LOCAL AND NATIONAL CODE.
3. Do not install this track in damp or wet locations.
4. Do not install any part of the track less than 7 feet above the floor.
5. Do not install any fixture assembly closer than 6 inches from any curtain, or similar combustible material.
6. Turn off power prior to any work on the systems.
7. Do not attempt to energize anything other than lighting track fixtures specified for use with the FLIGHT system.
8. To reduce the risk of fire and electric shock, do not attempt to connect power tools, extension cords, appliances, and the like to the track.
9. This track system **MUST BE HARD WIRED**. For all the wire connections, use Listed Wire Nuts.
10. No circuit is to exceed 300W or transformer capacity.
11. Secondary connections must be clean and tight to avoid arcing and overheating!
12. Warranty is void in case of unauthorized modifications and/or improper use.

READ ALL OF THESE INSTALLATION INSTRUCTIONS BEFORE INSTALLING THE SYSTEM

PART NUMBER

225090mc	matte chrome, 4' diameter
225090g	gold, 4' diameter

MATERIALS

- A. Flight Power Feed
- B. Flight Suspension Support
- C. Flight Connector
- D. Flight Track

