

ROOF MOUNT REMOTE SOLAR POWERED ATTIC VENTILATOR

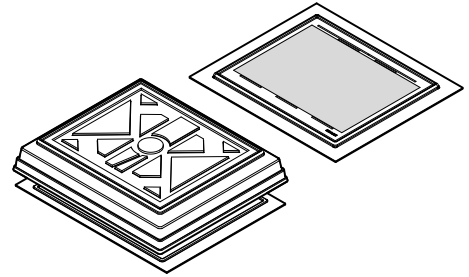

Powerful and easy to install, these ventilators supplement air conditioning by automatically removing the blanket of hot, trapped air from attics without the need of AC power.

FEATURES

- High efficiency 20 watt multicrystalline solar panel with high transmission tempered glass withstands up to 1" diameter hail and operates from dawn to dusk even in hazy conditions.
- Remote mount solar panel includes 15' of wire. For installations requiring a longer length of wire, an additional 50' of 14 AWG (minimum) UL listed or recognized copper wire may be used (purchase separately).
- Precision balanced 12" diameter, one piece, aluminum, 5 blade fan with optimum pitch for maximum air flow and minimum sound.
- 0.100" thick acrylic capped ABS plastic dome and base provide ultraviolet protection and superior durability. Available in black and brown.
- Heavy gauge corrosion resistant stainless steel screen with 0.125" square openings provide maximum protection from animals without impeding air flow.
- Whisper quiet, direct current, variable voltage (1-38 VDC) motor with permanently lubricated sealed ball bearings, hardened stainless steel shaft, zinc plated steel motor housing, dynamically balanced for superior performance.
- 16 AWG stainless steel brackets and stainless steel hardware provide sound construction and excellent corrosion resistance.
- Mounts easily between rafters.
- Can replace existing powered attic ventilators.

CONTROLS DESIGNED FOR USE WITH THESE PRODUCTS (purchase separately):

- Model CWT50 thermostat turns ventilator off when temperature falls below 50°F

TYPICAL SPECIFICATION

Roof Mount Remote Solar Powered Attic Ventilator shall be Broan Model 355RSOBK (355RSOBR).

Ventilator to be rated for attics up to 1600 square feet.

Ventilator shall mount easily between rafters or wall studs.

Solar panel to be rated at 20 watts and have high transmission, tempered glass.

Motor shall be direct current (DC), variable voltage, sealed, permanently lubricated, and corrosion resistant.

Fan blade to be metal, balanced, and corrosion resistant.

Dome and base must be constructed of ultraviolet resistant plastic.

Brackets, hardware and screen shall be corrosion resistant stainless steel.

SPECIFICATIONS

MODEL	COLOR	ATTIC MAX. SQ. FT.	MIN INLET AREA SQ. FT.
355RSOBK	BLACK	1600	4.25
355RSOBR	BROWN	1600	4.25

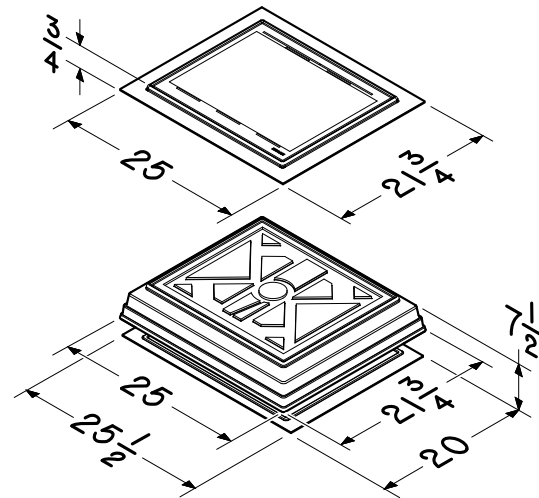

Broan-NuTone LLC Hartford, Wisconsin www.broan.com 800-558-1711

REFERENCE	QTY.	REMARKS	Project
			Location
			Architect
			Engineer
			Contractor
			Submitted by Date