

MODEL QTXE110150DCSL QT DC SERIES HUMIDITY SENSING FAN/LIGHT

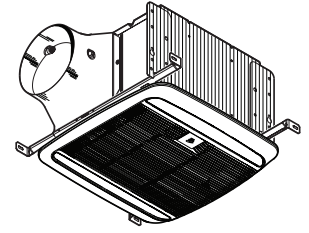

DESCRIPTION

BLOWER:

- Plug-in, permanently lubricated, brushless DC motor - engineered for continuous operation
- Dynamically balanced centrifugal blower wheel for quiet, efficient performance
- Low RPM for quiet operation
- Airflow-smoothing baffles reduce turbulence
- Selectable setting of 110, 130 or 150 CFM

HOUSING:

- Rugged, galvanized steel construction
- Metal, 6" round damper/duct connector with no metallic clatter
- 7-5/8" height allows for 2" x 8" ceiling installations
- Sturdy, easy, four-point mounting directly to joist
- Includes unique, patented spacer for mounting to engineered "I" joists
- Includes hanger bars to position housing anywhere between 16" to 24"-on-center joists

LIGHTING / GRILLE:

- Highly efficient, 18 Watt, integrated LED, dimmable
- LED lasts up to 25,000 hours
- Unique, low profile design for wide light pattern
- Even lens diffusion eliminates hotspots

TO OPERATE FAN AND LIGHT:

- Use only an ON/OFF or timer switch to operate the fan.
- Use only an ON/OFF switch, timer switch or relay-switch to operate the LED light.
- The LED light can be used with some dimmable switches (see below).
- Both the fan and LED light can be put on one switch.

DIMMING CONTROLS :

- May not be compatible with all dimmer controls
- Each application is unique and various factors such as load, common neutrals or other electrical products on the circuit can, in certain instances, cause variance in system performance.

- Dimmer model numbers vary slightly depending on color, packaging type, etc. such that variations of Model numbers may be suitable. Consult dimming system manufacturer for additional support in operation

* For a list of compatible controls, see broan.com.

HUMIDITY SENSING TECHNOLOGY:

- Detects humidity at the ceiling where it is greatest, which minimizes reaction time.
- Automatically turns fan on when either of these conditions is detected:
 - Rapid to moderate humidity increase;
 - Humidity above set point (50%-80% RH).
- Humidity level is set with easily accessible user adjustment.
- Can be used to comply with CALGreen standards.
- Two wire manual operation for odor control - Turns fan ON when power line through wall switch is cycled ON, OFF and back ON.
- After humidity has stabilized and is below set point or after turned on through power line cycling, fan remains on until user adjustable (5 to 60 minutes) time delay set point is reached.

U.L. Listed for use over bathtubs and showers when connected to a GFCI protected branch circuit (ceiling mount only).

U.L. Listed for use in insulated ceilings (Type IC).

3-Year Warranty



Broan Hartford, Wisconsin www.broan.com 800-558-1711

Venmar Ventilation ULC Drummondville (Quebec), Canada www.broan.ca 877-896-1119

| REFERENCE | QTY. | REMARKS | Project |
|-----------|------|---------|------------------------------------------------------|
| | | | Location |
| | | | Architect |
| | | | Engineer |
| | | | Contractor |
| | | | Submitted by Date |

PERFORMANCE RATINGS

MODEL QTXE110150DCSL QT DC SERIES HUMIDITY SENSING FAN/LIGHT

HVI PERFORMANCE

| Speed Setting | Static Pressure (In. H2O) | Airflow (CFM) | Sound (Sones) | Power (Watts) | Efficacy (CFM/W) |
|---------------|---------------------------|---------------|---------------|---------------|------------------|
| 110 | 0.1 | 110 | < 0.3 | 8.3 | 13.8 |
| | 0.25 | 91 | 0.9 | 12.0 | 7.9 |
| 130 | 0.1 | 130 | 0.4 | 10.3 | 12.8 |
| | 0.25 | 130 | 1.2 | 17.7 | 7.4 |
| 150 | 0.1 | 150 | 0.7 | 13.9 | 11.0 |
| | 0.25 | 144 | 1.4 | 21.1 | 6.9 |



HVI-2100 CERTIFIED RATINGS comply with new testing technologies and procedures prescribed by the Home Ventilating Institute, for off-the-shelf products, as they are available to consumers. Product performance is rated at 0.1 in. static pressure, based on tests conducted in a state-of-the-art test laboratory. Sones are a measure of humanly-perceived loudness, based on laboratory measurements.

AIR FLOW PERFORMANCE

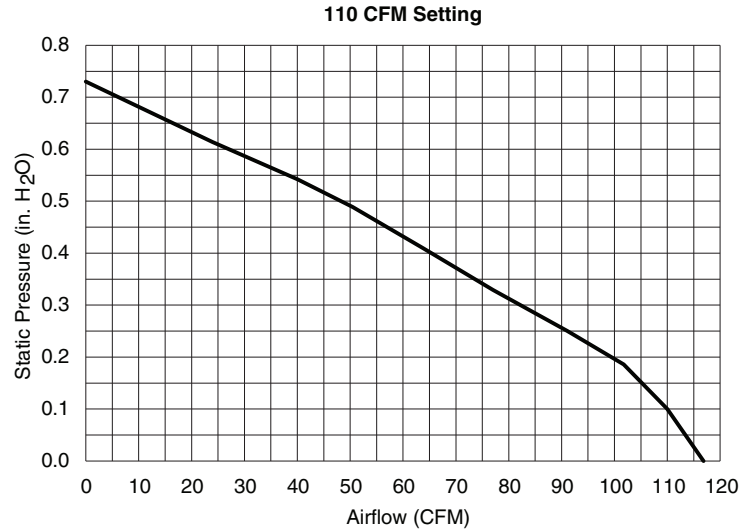

ELECTRICAL & WEIGHT

| Volts | Hz | Amps | Shipping Weight |
|-------|----|------|-----------------|
| 120 | 60 | 0.5 | 13.8 lbs. |

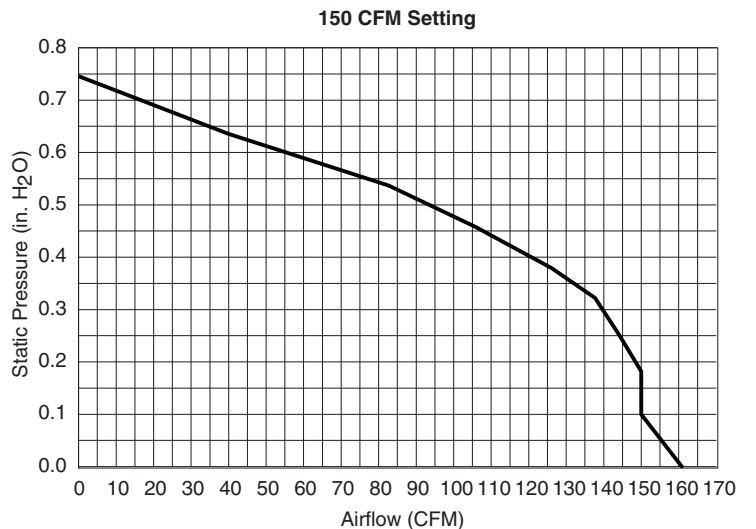
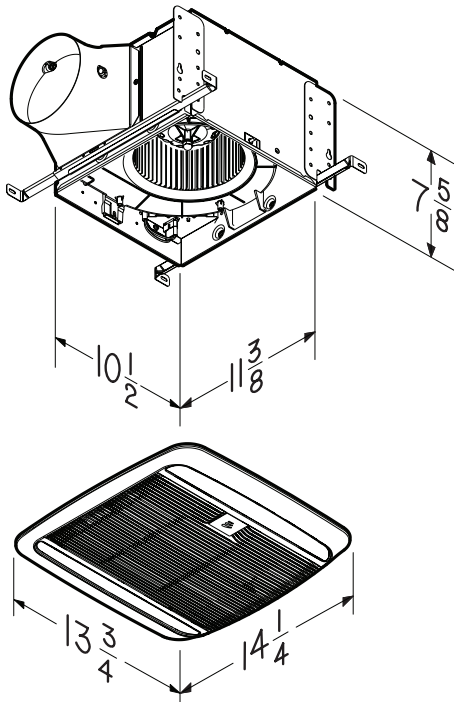
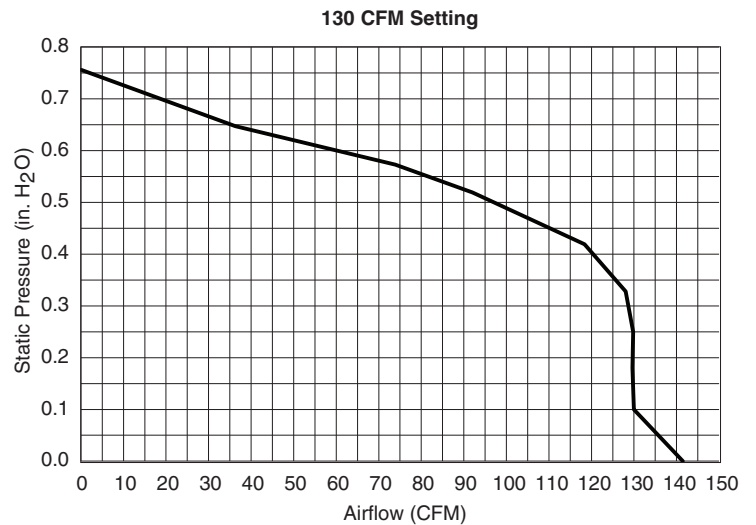

Broan Hartford, Wisconsin www.broan.com 800-558-1711
 Venmar Ventilation ULC Drummondville (Quebec), Canada www.broan.ca 877-896-1119