

30" Gas Cooktop 500 Series White NGM5024UC

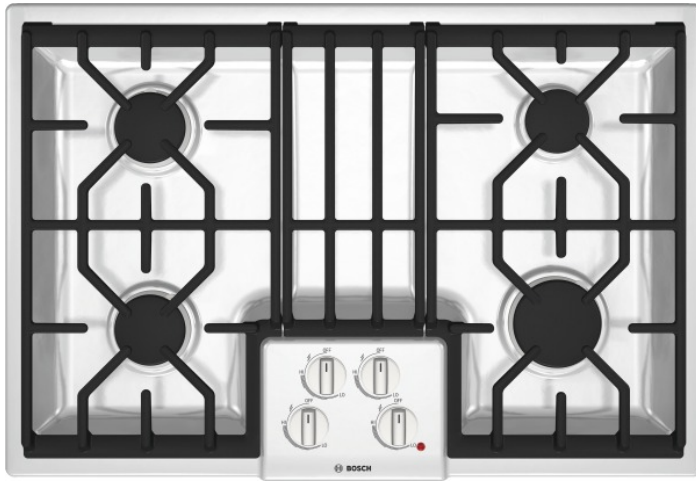

Features and Benefits

Key Features

- OptiSim® – Simmer Delicate Sauces without Scorching
- Centralized Controls for Easy Use and More Intuitive Operation of Cooktop.

Design

- High Quality Color Matched Knobs with a Stainless Bezel
- Cooktop Design Coordinates with Bosch Wall Ovens
- Low-Profile Design for a More Integrated Appearance

Performance

- Powerful 16,000 BTU Burner

Convenience

- Automatic Electronic Re-Ignition - in Case Flame Goes Out the Burner is Automatically Re-Ignited
- Continuous Grates - Effortlessly Move Pots and Pans. Easy to Clean
- Sealed Burners Prevent Spills From Entering the Burner Box

Notes: All height, width and depth dimensions are shown in inches. *Please refer to installation instructions prior to making cutout. BSH reserves the absolute and unrestricted right to change product materials and specifications, at any time, without notice. Consult the product's installation instructions for final dimensional data and other details. Applicable product warranty can be found in a accompanying product literature or you may contact your account manager for further details.

For more information on our entire line of products, go to boschappliances.com or call 1-800-944-2904.
Copyright ©2014 BSH Home Appliances Corporation. All rights reserved. Bosch is a registered trademark of Robert Bosch GmbH.

Litho Date: 01/2014

30" Gas Cooktop 500 Series White NGM5024UC

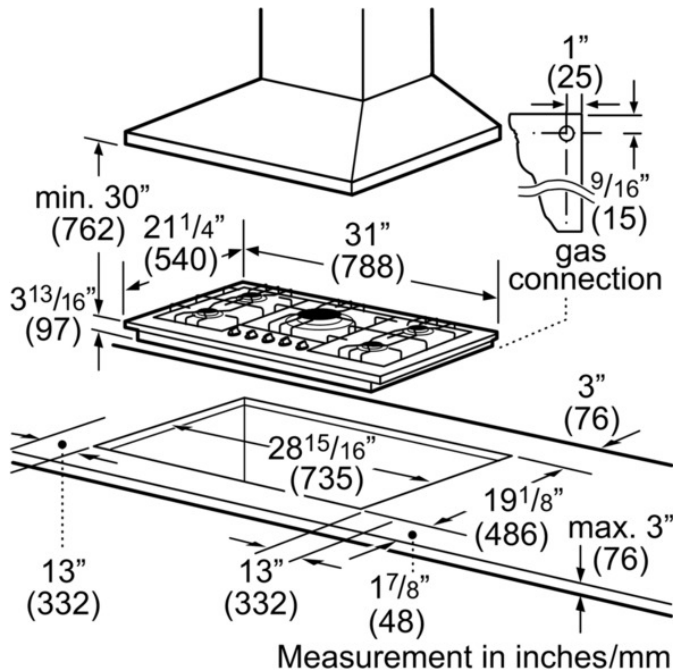

Features

Knob Material	Plastic
Sealed Burners	Yes
Burners with booster	
Type of grate	Cast iron
Total BTU load	41500
LP Gas Connection Rating (BTU)	38700
Power of 1st heating element (kW in boost)	
Dimension of 1st heating element (in)	
Power of 2nd heating element (kW in boost)	
Dimension of 2nd heating element (in)	
Power of 3rd heating element (kW in boost)	
Dimension of 3rd heating element (in)	
Power of 4th heating element (kW in boost)	
Dimension of 4th heating element (in)	
Power of 5th heating element (kW in boost)	
Dimension of 5th heating element (in)	
Power of 6th heating element (kW in boost)	
Dimension of 6th heating element (in)	

Technical Specification

UPC code	825225858355
Variant color	White
Energy source	Gas
Gas type	Natural gas 15 mbar (USA)
Alternative gas type	Liquid gas 27,5 mbar (USA)
Watts (W)	1800
Current (A)	15
Volts (V)	120
Frequency (Hz)	60
Approval certificates	CSA
Power Cord Length	60"
Plug type	120V-3 prong
Required cutout size (HxWxD) (in)	3 13/16" x 28 15/16" x 19 1/8"
Minimum distance from counter front (in)	1 7/8"
Minimum distance from rear wall (in)	3"
Overall appliance dimensions (HxWxD) (in)	+3 13/16" x 31" x 21 1/4"
Product packaging dimensions (HxWxD) (in)	8 3/8" x 37 1/8" x 24 3/4"
Net weight (lbs)	37
Gross weight (lbs)	45
Total number of cooktop burners	

Notes: All height, width and depth dimensions are shown in inches. *Please refer to installation instructions prior to making cutout. BSH reserves the absolute and unrestricted right to change product materials and specifications, at any time, without notice. Consult the product's installation instructions for final dimensional data and other details. Applicable product warranty can be found in a accompanying product literature or you may contact your account manager for further details.

For more information on our entire line of products, go to boschappliances.com or call 1-800-944-2904.

Copyright ©2014 BSH Home Appliances Corporation. All rights reserved. Bosch is a registered trademark of Robert Bosch GmbH.

Litho Date: 01/2014