

MINIPRESS M boring and insertion machine

Please keep a copy of the Operators' Manual accessible to machine operators.

Only those individuals who are properly trained and who have read and understood the Operators' Manual may set up, operate, or service this machine.

 **blum**[®]

BA-107/2EA M52.10XX

This machine has been manufactured using the highest quality materials to provide long lasting performance. Rigorous quality controls and a final inspection ensure that each machine is delivered in good working condition. These quality control measures enable Blum to offer this one year limited warranty on the machine, starting with the date of delivery.

Information is set forth below regarding a general description of the warranty on this machine. However, the specific warranty provisions are contained in the Blum terms of sale, and those provisions constitute the specific terms of the warranty provided for this machine.

Unless otherwise specifically agreed to in writing signed by a representative of Blum, THERE ARE NO OTHER WARRANTIES, EXPRESS OR IMPLIED, INCLUDING A WARRANTY AS TO MERCHANTABILITY OR FITNESS FOR A PARTICULAR PURPOSE. THERE ARE NO WARRANTIES WHICH EXTEND BEYOND THOSE SPECIFICALLY DESCRIBED IN THE TERMS OF SALE.

Should any defect be found in the machine, please submit to Blum, in writing, the reference number, the serial number, and the name of the distributor from whom the machine was purchased. Replacement parts included under this warranty will be furnished free of charge.

This warranty or guarantee only includes the replacement of components; however, it excludes assembly times, driving times, incidental or consequential damages, etc. For your own safety, you should only use Blum-approved replacement parts and accessories. Blum is not liable for any damages resulting from the use of unapproved products.

In no event shall Blum be liable for:

- damage in transportation (please file a claim immediately with the carrier)
- Blum is not responsible for any damage caused from misuse or improper equipment operation.
- lost production time
- loss of earnings
- lost or damaged materials
- parts which are subject to normal wear
- Drill bits
- damage caused by not observing the safety rules.

Dear valued Blum customer,

We would like to congratulate you on your decision to purchase the Blum boring and insertion machine. You are now the owner of a modern, high-quality machine that will give you years of productive use with the proper care and maintenance.

We realize that your time is valuable. However, you should carefully read these operating instructions before you set up and use the machine for the first time. In this way, you will best determine how to adjust the machine to your needs as well as protect yourself against injury. In addition, the operating instructions also contain important information about machine maintenance.

At the time of printing, these operating instructions contained up-to-date information for this model. This information is subject to change due to continual development of the machine design. These operating instructions are an important component to the machine and must be transferred to the new owner if the machine is sold.

For your own safety, you should only use Blum-approved replacement parts and accessories. Blum is not liable for any damages resulting from the use of unapproved products.

Blum GmbH retains the right to make changes to and/or cancel without replacement the technical design, equipment, technical information, color, materials, services provided and similar without prior notice and without explanation as well as the right to discontinue production of a specific model also without prior notice.

1. Machine information	
A - Limited warranty	3
B - Table of contents	4
C - How to use this manual	5
D - Safety information	6
D.1 - Safety decals	6
D.2 - Intended use	6
D.3 - Safety instructions	6
E - Orientation diagram	8
2 - Machine setup	10
2.1 - Unpacking and assembly	10
2.1.1) Machine space requirement	10
2.1.2) Unpacking machine and attaching to a suitable table	10
2.1.3) Positioning (2.2) base ruler	10
2.1.4) Attaching ruler stops	10
2.1.5) Attaching work table	11
2.3 - Electrical connection	11
2.3.1) Electrical connection	11
2.4 - Dust extraction	11
2.4.1) Connecting extraction system to the machine	11
3 - Motor start button	11
4 - Hinge installation	12
4.1 - Concealed hinge installation	12
4.1.1) Required parts	12
4.1.2) Setting drill bit length	12
4.1.3) Setting boring pattern	12
4.1.4) Inserting drill bits	12
4.1.5) Setting boring depth	12
4.1.7) Boring depth stop (4.11)	13
4.1.10) Setting the boring distance (2.4)	13
4.1.13) Setting ruler stops (2.7)	14
4.1.14) Placing door on the work table and pushing up against the stop	14
4.1.16) Attaching insertion ram to swing arm (4.8)	14
4.1.17) Clipping concealed hinge on to the insertion ram	14
4.1.18) Boring	15
4.1.19) Checking the tilt adjustment of the swing arm (4.8)	15
4.1.20) Inserting the concealed hinge	15
5 - Mounting plate installation	16
5.1 - Wing mounting plate installation	16
5.1.1) Required parts	16
5.1.2) Setting drill bit length (see point 4.1.2)	16
5.1.3) Setting boring pattern	16
5.1.4) Installing drill bits into the chuck	16
5.1.5) Checking boring depth setting	16
5.1.7) Setting the boring distance (2.4)	16
5.1.8) Setting the ruler stops (2.7)	16
5.1.9) Placing cabinet side on the work table and pushing up against the stop	16
5.1.10) Boring	16
6 - Other installation	17
6.1 - Boring hole groups	17
6.1.1) Required parts	17
6.1.2) Setting drill bit length	17
6.1.3) Setting boring pattern	17
6.1.4) Inserting drill bits into the chuck	17
6.1.5) Checking boring depth setting	17
6.1.7) Setting the boring distance (2.4)	17
6.1.8) Setting the ruler stops (2.7)	17
6.1.10) Placing cabinet side on the work table and pushing up against the stop	17
6.1.12) Boring	17
7 - Maintenance and service	18
7.1 - Maintenance	18
7.1.1) Maintenance	18
7.1.2) Damaged clutch	18

8 - Troubleshooting	19
8.1 - Error during boring	20
8.2 - Hardware insertion error	21
8.3 - Function errors	21
9 - User-supplied work table	22
10 - Electrical diagram	23
11 - Technical data	23

C - How to use this manual

- Please keep a copy of the Operators' Manual accessible to machine operators.
- We recommend that you use the orientation diagram for easier identification of the parts being described.
- Individual sections are indicated by capital letters which makes it easier to navigate the instructions.

**ATTENTION:**

This exclamation point indicates important safety information that must be followed.

**IMPORTANT:**

This exclamation point indicates an important comment. If this comment is not followed, then machine components as well as the work piece itself may be damaged or the machine may be rendered inoperable and/or the work piece unusable.

(3.1) Component description codes correspond to the section where the component and its function is described. For example, **(3.1)** is described in section 3.

D.1 - Safety decals

	<p>Before connecting your machine to a power source, be sure to read and understand ALL safety instructions, warning labels and the Operators' Manual!</p>
	<p>Wear safety glasses or full face shield when setting up, operating or servicing this machine.</p>
	<p>Keep unauthorized people away from the machine. Only one person at a time must operate this machine.</p>
	<p>Keep hands away from the drill bits or swing arm during the boring or insertion process. Do not remove safety devices - danger of injury.</p>

D.2 - Intended use

- This machine is designated for commercial and industrial applications and shall be used by fully trained professionals only. The machine is only intended for the boring and insertion of Blum hardware into panels of wood or laminated particle board. The machine should not be used for any other purpose.
- The machine is not explosion-proof. It should not be set up near a paint finishing system or any other environment where an explosion hazard exists
- Do not setup or use the machine in a wet environment or in an environment which may become wet..

D.3 - Safety instructions

- Read and understand this Operators' Manual before setting up, operating, or servicing the machine.
- Only licensed electricians should connect electrical power to this machine or perform maintenance or service operations on electrical components of this machine.
- To prevent electrical shock, do not operate the machine near wet areas or where the machine may become wet.
- To minimize fire risk, this machine must be connected to dust suppression system (see section 2.4).
- Machine is intended for one person operation only.
- Do not operate the machine with any cover or panel removed.
- Eye protection required at all times while setting up, operating, or servicing this machine.
- Keep all body parts clear of point of operation when machine power is on.
- Disconnect electrical power from the machine before removing any cover or panel.
- Disconnect electrical power from machine before performing maintenance and service operations.





- Maintenance and service must be performed by qualified and authorized personnel only.
- Operators and service personnel must follow all LOCKOUT / TAGOUT procedures established by management.
- Particular care must be taken when working on sections that extend out over the worktable. Attach a larger work table or use extensions.
- Secure the work piece during boring/insertion.
- You should always check that all safety devices and machine parts are functioning properly before use. Replace damaged parts with original Blum parts.
- Make sure that no other tools or objects are on the work table aside from your work piece before turning on the machine.
- After finishing work, disconnect the machine from the power supply. **(3.1)**
- CAUTION: For your own safety, use only those accessories which are recommended or indicated in the manual or Blum sales literature.
- **Do not make any alterations or modifications to the machine.**
- If there are any questions and/or problems, please contact the BLUM Customer Service Department at 1-800-438-6788 or www.blum.us
- **Failure to follow these instructions and the warnings provided on the machine may result in serious bodily injury or death.**
- For additional copies of the Operator's Manual or if there are questions with regard to the safe operation of this machine, contact BLUM USA at 1-800-438-6788.



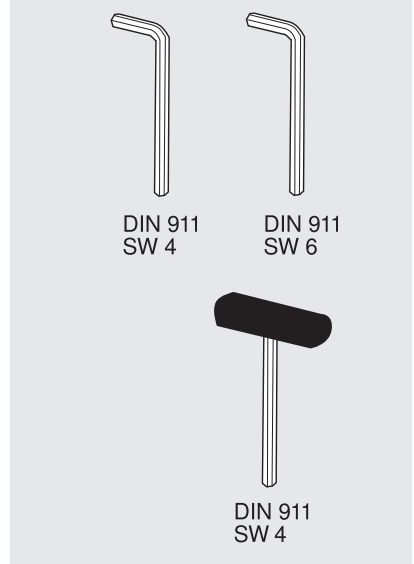
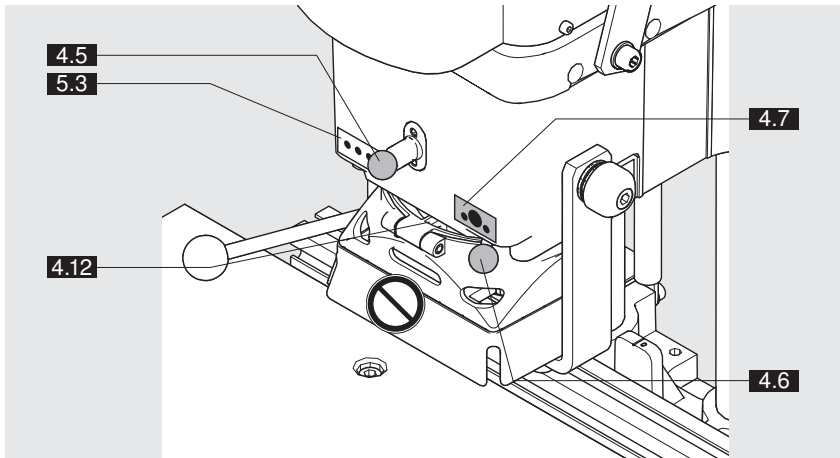
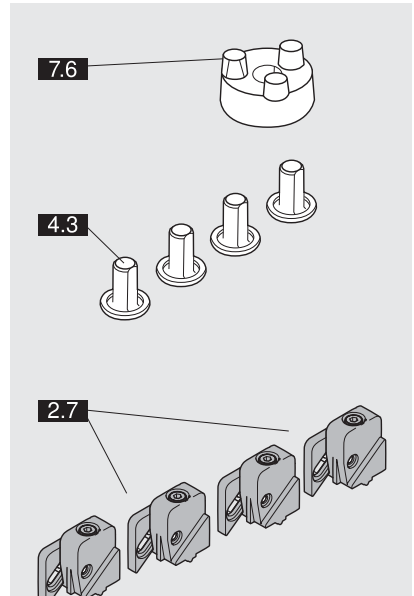
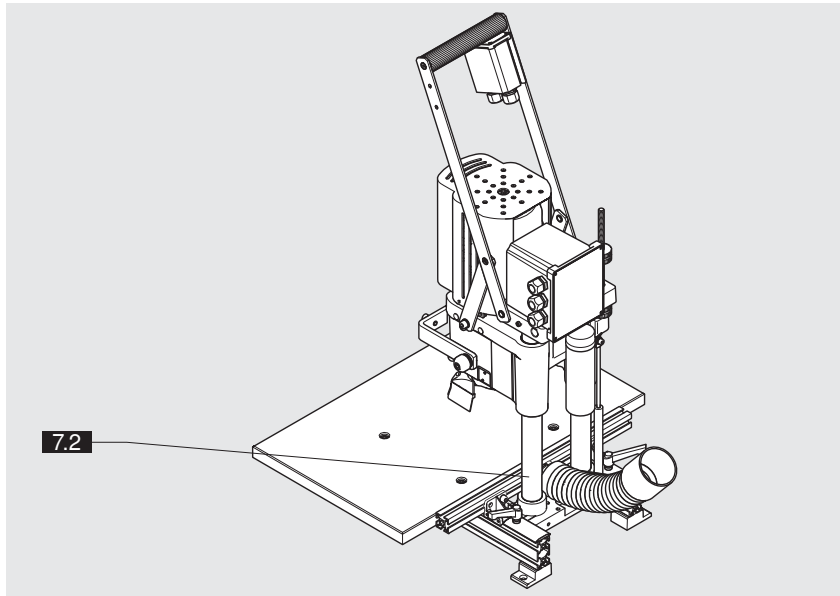
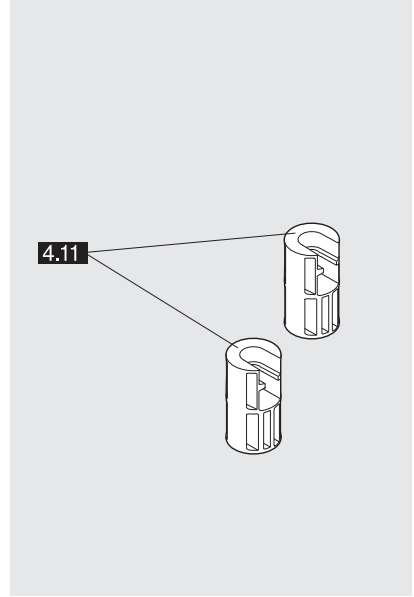
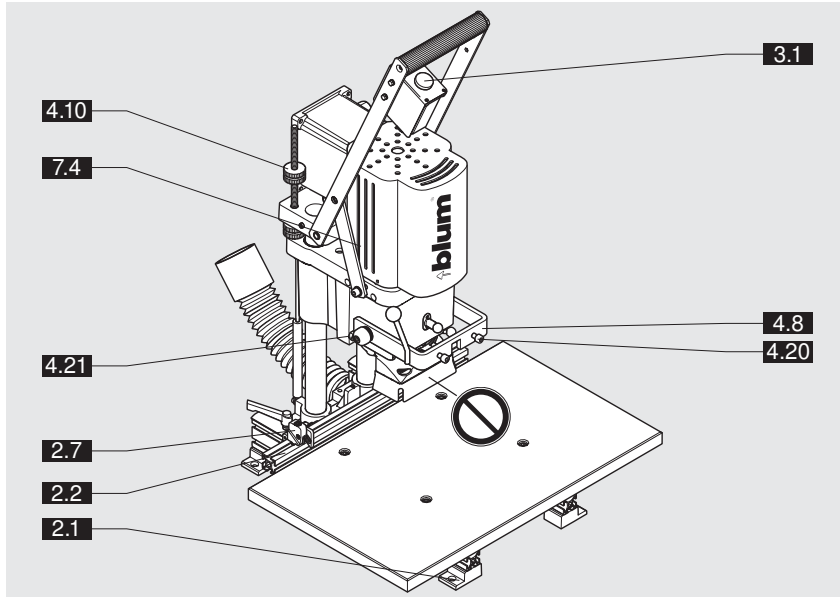

 Do not remove!

- | | | | |
|-------------|-------------------------------|------------|--------------------|
| 2.1 | Mounting foot | 5.3 | Hole group symbol |
| 2.2 | Base ruler | 7.2 | Columns |
| 2.7 | Ruler stop | 7.6 | Replacement clutch |
| 3.1 | Motor start button | | |
| 4.3 | Chuck cover cap | | |
| 4.5 | Boring head securing knob | | |
| 4.6 | Boring head rotating lever | | |
| 4.7 | Concealed hinge symbol | | |
| 4.8 | Swing arm | | |
| 4.10 | Boring depth adjustment wheel | | |
| 4.11 | Boring depth stop | | |
| 4.12 | Safety shield ring | | |
| 4.20 | Mounting screw | | |
| 4.21 | Swing arm adjustment screw | | |

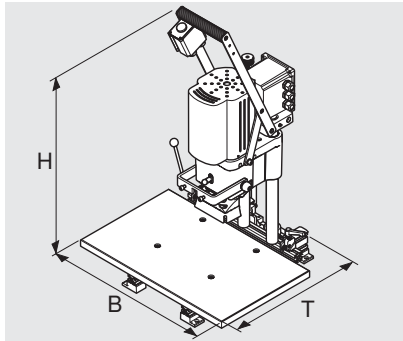

2.1 - Unpacking and assembly

2.1.1) Machine space requirement

Height (H) = 38" (965 mm)
 Width (W) = 24" (610 mm)
 Depth (D) = 24" (610 mm)

- Completely loosen bottom knurled hand wheels

Note:

This hand wheels may be positioned to adjust upper stop position of handle.

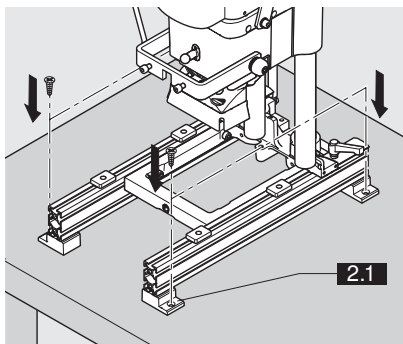
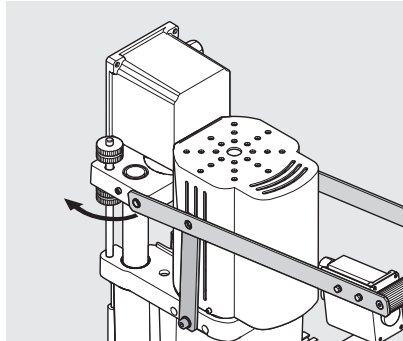

2.1.2) Unpacking machine and attaching to a suitable table

- Open box
- Use two people to lift the assembly machine onto the work table



ATTENTION:

The machine weighs approx. 82 lbs.

The table or stand must be of sufficient stability to accommodate this

- The machine should not be set up in a wet environment. The area must be dry.
- Pre-drill holes and then attach machine **[2.1]** using the proper screws/bolts.

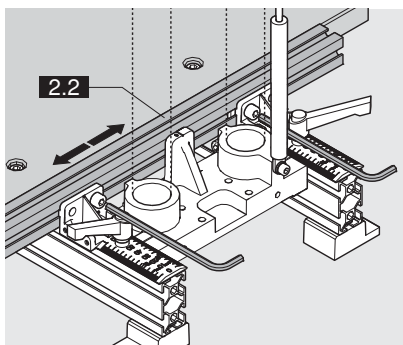

2.1.3) Positioning base ruler **[2.2]**

- Place ruler on mounting bracket
- Line up the "0" mark on the center ruler with the "0" mark on the machine base
- Clamp ruler

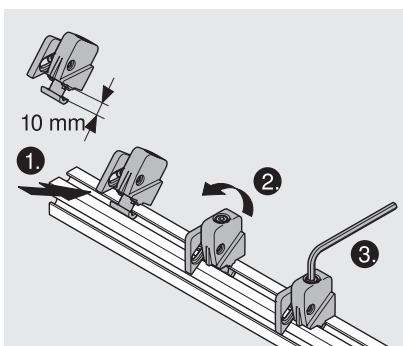

2.1.4) Attaching ruler stops

- Loosen clamping screw until the location plate protrudes 10 mm
- Attach stop to ruler at an angle and stand upright
- Tighten clamping screw

IMPORTANT:

This procedure can also be used to set a stop between two already positioned stops.

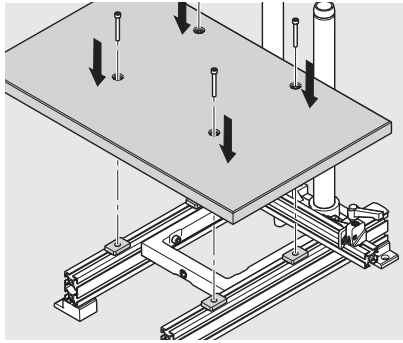

2.1.5) Attaching work table

- a) Accessory work table (Blum reference number MZA.5200)
 - Set work table on runner plate
 - Attach work table to runner plate
- b) For details of how to construct a work table, see Chapter 9 - Appendix

! **IMPORTANT:**
 With plastic spacers installed, the distance between the top of the ruler and the top of the worktable is 6.6 mm. Without the spacers the difference is 13.6 mm (for work pieces with a profile edge)

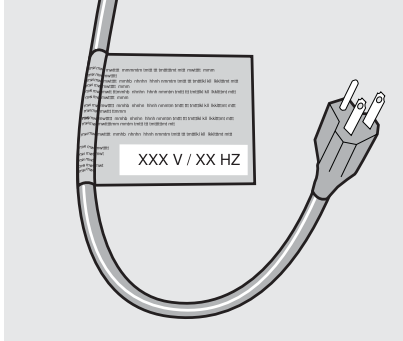

2.3 - Electrical connection

2.3.1) Electrical connection

- The machine comes with a connector.

! **ATTENTION:**
 The machine is designed for the voltage printed on the label of the connection cable.
 See National Electrical Code (NEC) for proper grounding. Receptical must be within sight of operator.

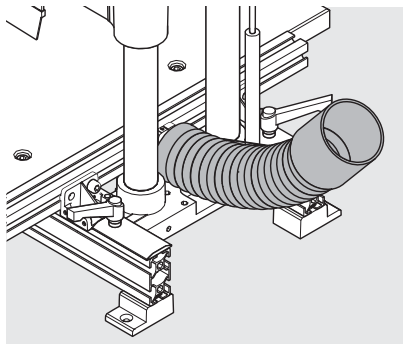

2.4 - Dust extraction

2.4.1) Connecting extraction system to the machine

! **ATTENTION:**
 To minimize the risk of fire this machine must be connected to a dust extraction system!

- Make sure that the average air velocity for the extraction system is at least 66 ft/sec.

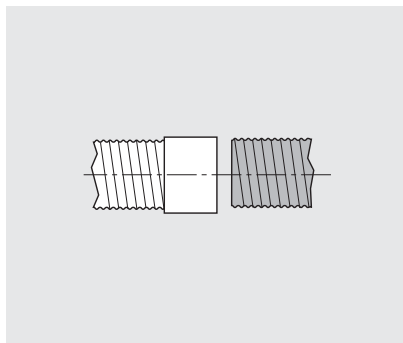

- Insert the spiral hose with an inside diameter of approx. 3.75 inches into the receiving tube and secure it.

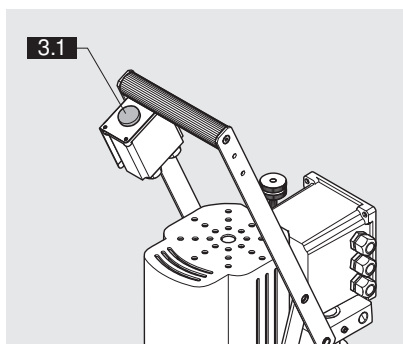

3 - Motor start button

3) Using the motor start button (3.1)

- Press and hold to activate the motor.

! **ATTENTION:**
 All items except for the work piece should be removed from the work area of the machine. Keep your hands out of work area .

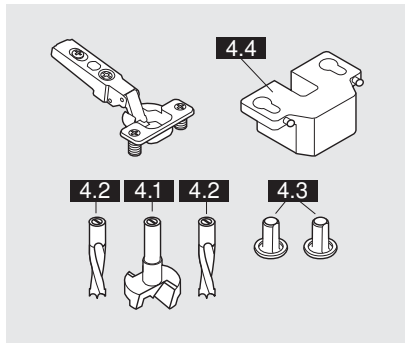

4.1 - Concealed hinge installation

4.1.1) Required parts

- Drill bits:
 - 1x \varnothing 35 mm clockwise (4.1) (marked in black)
 - 2x \varnothing 8 mm counterclockwise (4.2) (marked in orange)
- Cover caps (4.3)
- Insertion ram MZM.00XX (4.4) (see catalogue to determine the proper insertion ram for the respective concealed hinge)
- Concealed hinge

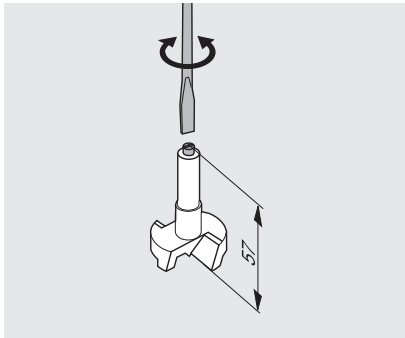

4.1.2) Setting drill bit length

- The total length of the drill bits (from bit-tip to adjustment screw) should be 57 mm
- To correct drill bit length, adjust screw accordingly using a screwdriver

! **IMPORTANT**
All drill bits must be the same length

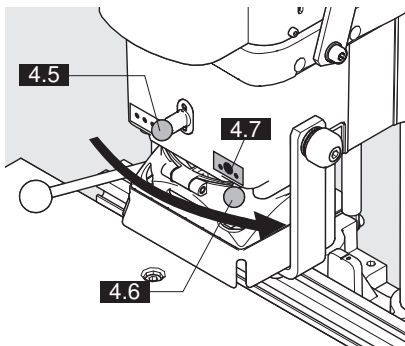

4.1.3) Setting boring pattern

- Pull spring loaded knob out (4.5)
- At the same time, move the lever (4.6) to the "Concealed hinge" symbol (4.7)
- Release knob back to original position (4.5)

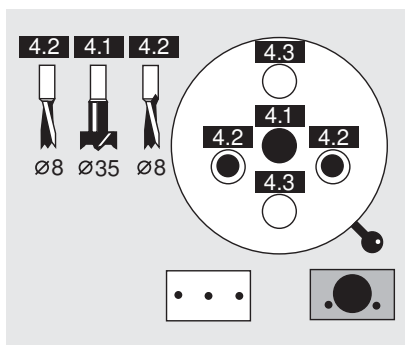

4.1.4) Inserting drill bits.

! **ATTENTION**
Disconnect machine from the power supply

- Push drill bits all the way into the chuck (The flat on the drill shank must be aligned with the set screw)
- Use a hex wrench to tighten the set screws
- Insert cover caps into the unused chucks (4.3). This will keep the chucks clean and prevent the set screws from shaking loose.

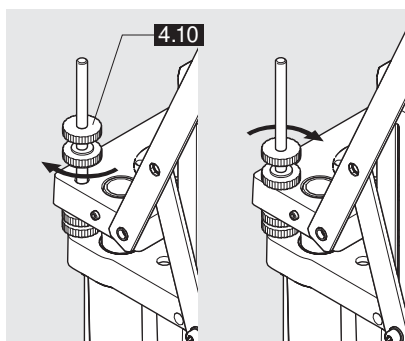

4.1.5) Setting boring depth

- Set boring depth using the bottom knurled hand wheel (4.10) (One turn equals 1.5 mm)
- Secure the bottom knurled hand wheel (4.10) (lock)

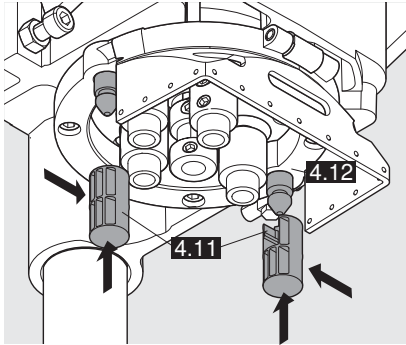

4.1.7) Boring depth stop (4.11)

Another option to maintain a constant boring depth is to install the boring depth stop. When the boring depth stop is installed, the boring depth is always 13 mm regardless of the thickness of the work piece. (see important note below)

Installing the boring depth stop:

- Disconnect machine from the power supply
- Remove drill bit
- Push boring depth stop into the locking holes of the retainer ring (4.12) until it engages and turn 90 degrees with force.
- Attach drill bit



IMPORTANT:

The drill bit length must be set to 57 mm. (See point 4.1.2). The knurled hand wheel should be adjusted so that it doesn't limit the boring depth. (See point 4.1.5)

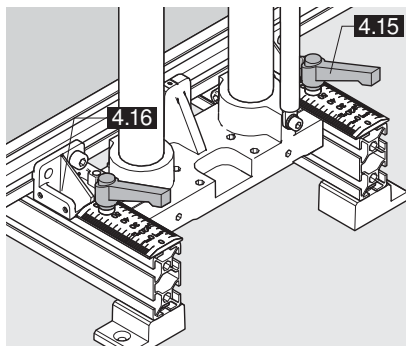

4.1.10) Setting the boring distance stop system

- Loosen the clamping lever (4.15)
- Remove locking pin (4.16) (optional) and set gauge (2.4) to position.
- Secure the clamping lever (4.15)

This setting provides the boring distance of 23.5 mm.

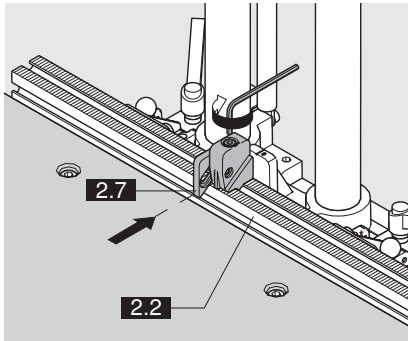

4.1.13) Setting ruler stops (2.7)

Set the ruler stops (2.7) to the desired dimension and clamp.

! **IMPORTANT:**
Indicator edge is on the inside of the sliding part.

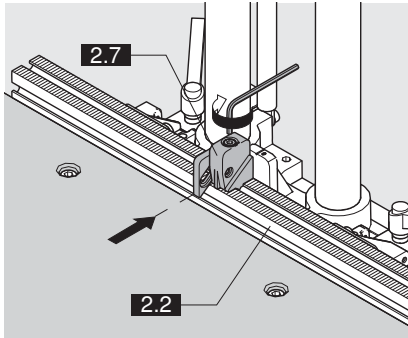

4.1.14) Placing door on the work table and pushing up against the stop

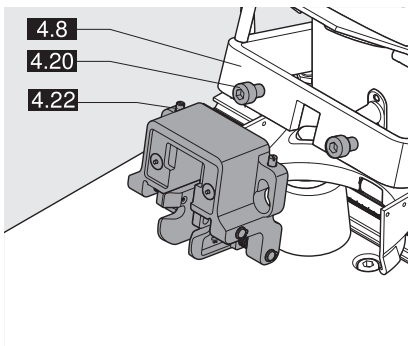

4.1.16) Attaching insertion ram to swing arm (4.8)

- Place insertion ram on to the two fixing screws (4.20) on the swing arm (4.8).
- Tighten the screws so that the insertion ram is secure.

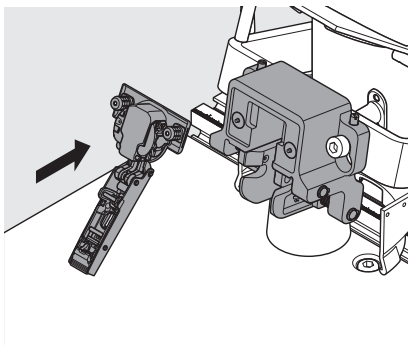

4.1.17) Clipping concealed hinge on to the insertion ram

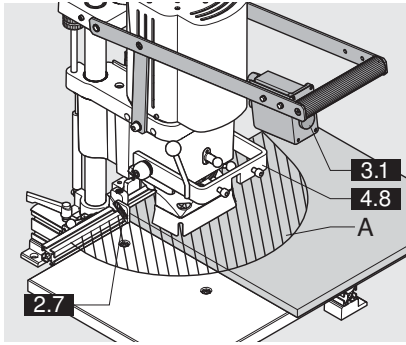

4.1.18) Boring



ATTENTION:

All items except for the work piece should be removed from the work area of the machine. Keep your hands out of work area (A).

- Swing arm (4.8) must be swivelled up.
- Hold down door outside of danger area (A) and press against the ruler stop (2.7).
- Pull handle down
- Press motor start button (3.1)
- Bore until the correct depth is reached
- Release motor start button (3.1)
- Push handle up

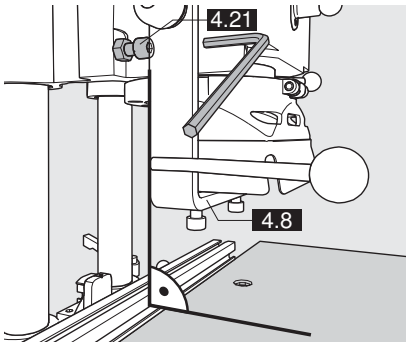

4.1.19) Checking the tilt adjustment of the swing arm (4.8)

- Swivel down swing arm (4.8) to the stop (4.21)
- Check whether or not the concealed hinge is aligned with the bored holes.
- If it is misaligned, this can be caused by two things:
 - a) Swivel arm (4.8) is not set vertical.
 - Use the screw to correct this setting (4.21)
 - b) Insertion ram is off-center.
 - Correct this setting using the adjustment screws (4.22) on the insertion ram.

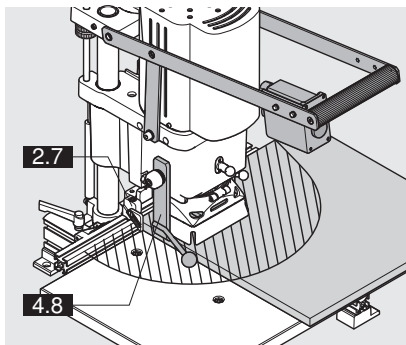

4.1.20) Inserting the concealed hinge



ATTENTION:

Keep your hands and other objects away from machine work area (A)

- Swivel down swing arm (4.8)
- Pull handle down to insert hinge into door.
- Swivel up swing arm (4.8)
- Remove door from the work table or push to the next stop (2.7)

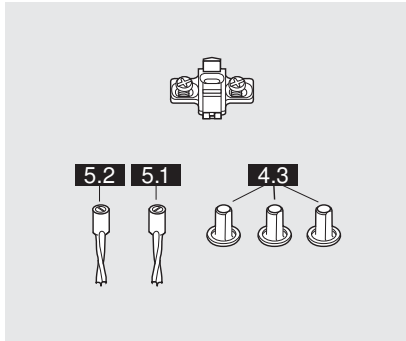

5.1 - Wing mounting plate installation

5.1.1) Required parts

- Drill bits:
 - 1 x $\varnothing 5$ mm clockwise (5.1) (marked in black)
 - 1 x $\varnothing 5$ mm counterclockwise (5.2) (marked in orange)
- Cover caps (4.3)
- Cabinet side
- Wing mounting plate with system screws

5.1.2) Setting drill bit length (57 mm) (see point 4.1.2)

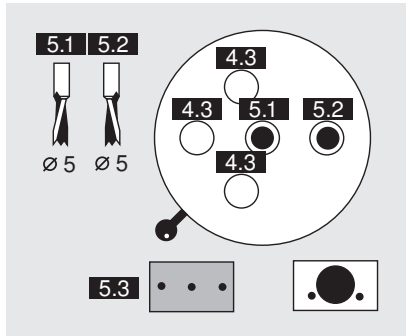

5.1.3) Setting boring pattern

- Pull spring loaded knob out (4.5)
- At the same time, move the lever (4.6) to the "Hole group" symbol (5.3)
- Release knob back to original position (4.5)

5.1.4) Installing drill bits into the chuck

(see point 4.1.4)

5.1.5) Checking boring depth setting

(see points 4.1.5 / 4.1.6 / 4.1.7)

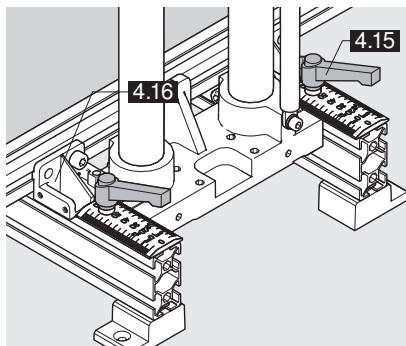

5.1.7) Setting the boring distance (2.4)

- Loosen the clamping lever (4.15).
- Remove locking pin (4.16) (optional) and set gauge (2.4) to SYS.
- Secure the clamping lever (4.15).

This setting provides the boring distance of 37 mm.

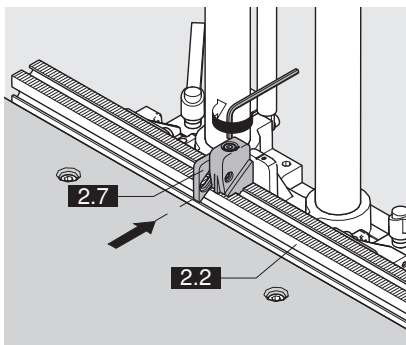

5.1.8) Setting ruler stops (2.7)

Set the ruler stops (2.7) to the desired dimension and clamp.

! **IMPORTANT:**
Indicator edge is on the inside of the sliding part.

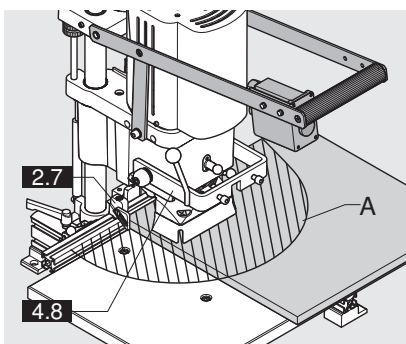

5.1.9) Placing cabinet side on the work table and pushing up against the stop (See point 4.1.14)

5.1.10) Boring

(See point 4.1.18)



ATTENTION:
Keep your hands and other objects away from machine work area (A)

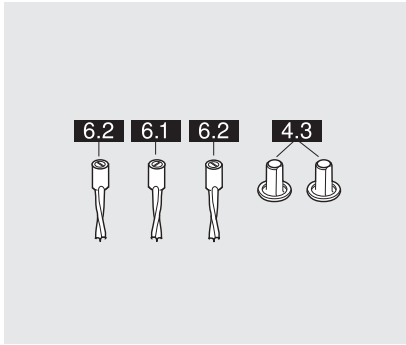

6.1 - Boring hole groups

6.1.1) Required parts

- Drill bits:
 - 1x \varnothing 5 mm clockwise (6.1) (marked in black)
 - 2x \varnothing 5 mm counterclockwise (6.2) (marked in orange)
- Cover caps (4.3)
- Cabinet side

6.1.2) Setting drill bit length

(See point 4.1.2)

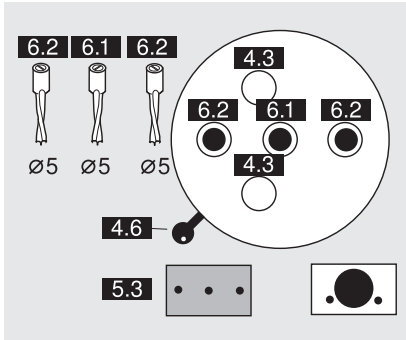

6.1.3) Setting boring pattern

- Pull spring loaded knob out (4.5)
- At the same time, move the lever (4.6) to symbol (5.3)
- Release knob back to original position (4.5)

6.1.4) Inserting drill bits into the chuck

(See point 4.1.4)

6.1.5) Checking boring depth setting

(see points 4.1.5 / 4.1.6 / 4.1.7)

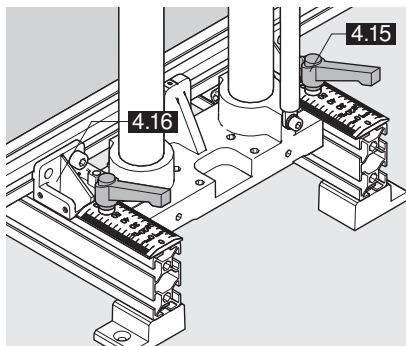

6.1.7) Setting the boring distance (2.4)

- Loosen the clamping lever (4.15).
- Remove locking pin (4.16) (optional) and set gauge (2.4) to SYS.
- Secure the clamping lever (4.15).

This setting provides the boring distance of 37 mm.

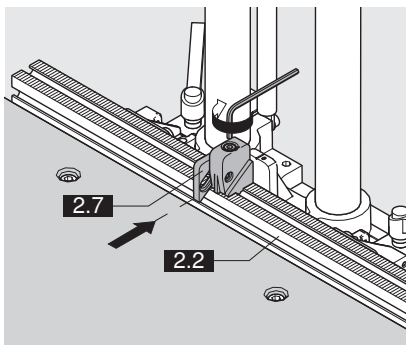

6.1.8) Setting ruler stops (2.7)

Set the ruler stops (2.7) to the desired dimension and clamp.

! IMPORTANT:
Indicator edge is on the inside of the sliding part.

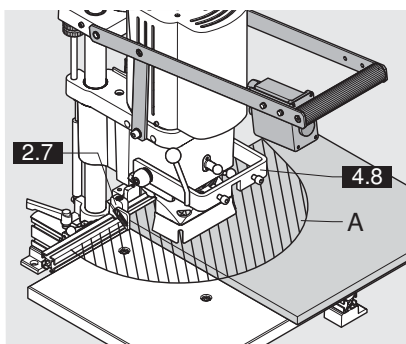

6.1.10) Placing cabinet side on the work table and pushing up against the stop

(See point 4.1.14)

6.1.12) Boring

(See point 4.1.18)



ATTENTION:
Keep your hands and other objects away from machine work area (A)

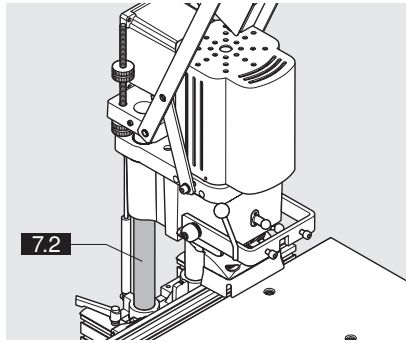

7.1 - Maintenance

7.1.1) Maintenance

- Dust chips should be removed from the machine on a regular basis
- Electrical lines should always be checked for damage before the machine is used
- The columns (7.2) are maintenance free and should not be oiled
- The columns (7.2) must be cleaned regularly with a dry cloth to remove dust. (Do not use cleaners or solvents)

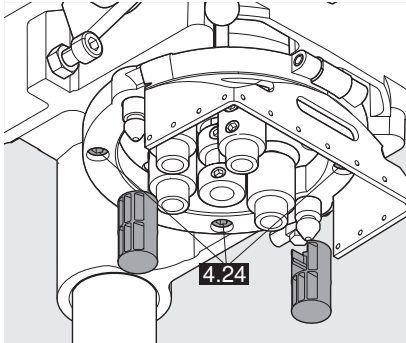

7.1.2) Damaged clutch

The clutch is damaged if:

- The bit is jammed in the work piece but the motor fan cooling continues (2.9) to turn.
- Disconnect electrical connection to the machine
- Remove drill bits
- Remove the 4 bolts that hold safety shield to gearbox housing (4.24)
- Move safety shield to one side then while holding internal gearbox, pull out boring head securing knob. (4.5) This will allow the internal gearbox to come down and out.
- Remove dampening ring (7.5)
- Remove old clutch (7.6)
- Attach replacement clutch (7.6) on to the spindle. (ensure correct positioning of clutch and spindle)
- Insert dampening ring (7.5)
- Preposition clutch base for alignment with motor
- Slide gear box up into housing
- Ensure clutch reengages
- Reinstall safety shield

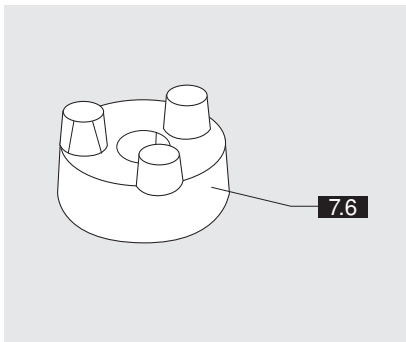
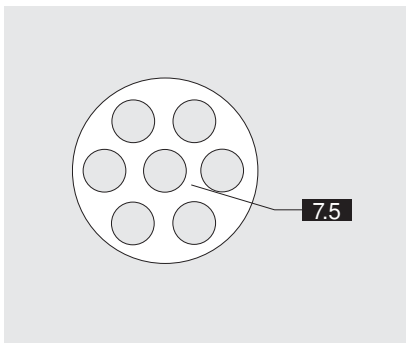

8.1 - Error during boring

Error	Cause	Solution	Comment
Bored holes too large, oval or ragged	Hole diameter is too large	Check bits	none
	Drill bits are warped or bent	Replace bits	none
	Boring speed is too high	Pull handle down slower	See point 4.1.18
	Boring through work pieces	Reset depth stop	none
	Drive shafts are bent, e.g. spindles are defective	Replace gearbox	none
Drill bit sticks or is jamming in wood	Improper material has been bored	Only use work pieces made from wood, particle board or MDF	none
	Boring speed is too high	Pull handle down slower	See point 4.1.18
	Clutch broken (motor runs, drill blockage in wood)	Replace defective Clutch	See point 7.1.2
	Bits are dull	Sharpen drill bits or replace	none
	Machine connected to the wrong voltage	Check supply voltage and compare with motor data. Have checked by licensed electrician	See chapter 10 - Diagrams
Drill bits cannot be inserted into the chucks	Chucks are full of chips	Clean drill chuck Use cover caps	none
	Drill bit shaft diameter too large or damaged	Repair drill bit shaft or replace	none

Error	Cause	Solution	Comment
Boring depth does not match	Boring depth set incorrectly	Correct boring depth setting	See point 4.1.5
	Drill bit length does not match	Drill bit length set to 57 mm	See point 4.1.2
	Drill bits not completely pushed into the chuck	Clean dirt from chuck and completely insert drill bit	See chapter 4
	Work piece thickness does not correspond to the given value (e.g. 15 mm instead of 16 mm)	Check work piece thickness, correct boring depth setting, use boring depth stop	See chapter 4
	Machine is contacting an object (e.g. ruler stop)	Remove object	none
	Motor start button was released before the boring depth was reached	Keep motor start button engaged until the boring depth has been reached	none
	Work table height (thickness)	Work table should be 24 mm thick	See chapter 9 - Appendix
Bored holes are off center or in the wrong position	The ruler stops are not set properly.	Check positions and stops and correct if necessary	none
	Ruler not set properly	Set ruler to the 0 point	See point 2.1.3
	Chips between the ruler and the work piece	Remove dirt and chips	none
	Extension ruler is not attached properly	Check ruler attachments and extension - check spacing of both rulers	none
	Spring loaded knob not set.	Allow index pin to engage	See point 4.1.3

8.2 - Hardware insertion error

Error	Cause	Solution	Comment
Hardware cannot be inserted or only with great difficulty	Insertion ram or swing arm is contacting an object (e.g. swivel stop)	Remove object	none
	The surface of the work piece is too hard	Chamfered holes	Use slip-on counter-sink
	Bored holes are not deep enough	See point "Boring depth not reached" Table spacers are missing	none See point 2.1.5
	The boring diameter is too small	Check drill bits and replace if necessary	none
	The insertion ram has shifted or turned	Set insertion ram	See point 4.1.16
	Chips are in the bored holes	Remove chips from holes	none
	Swing arm is not set properly	Check swing arm setting	See point 4.1.19

8.3 - Function errors

Error	Cause	Solution	Comment
Motor does not run	Machine is not connected to the power supply	Connect machine to the power supply	none
	Building circuit breaker has failed	Reset circuit breaker or replace	none
	Swing arm is in down position	Swivel swing arm up	See point 4.1.18
	Motor defective	Have motor replaced by an licensed electrician	none
Motor overheats	Machine connected to the wrong voltage	Check supply voltage and compare with motor data. Have checked by licensed electrician	See electrical diagram
	Boring in hard wood with too high a speed	Pull handle down slower	none
	Motor hood is dirty or covered by something	Remove objects and chips in the area of the motor hood	none
Gearbox defective	Support, spindles or gears are damaged	Replace gearbox	none

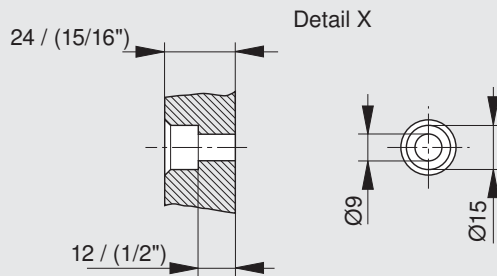
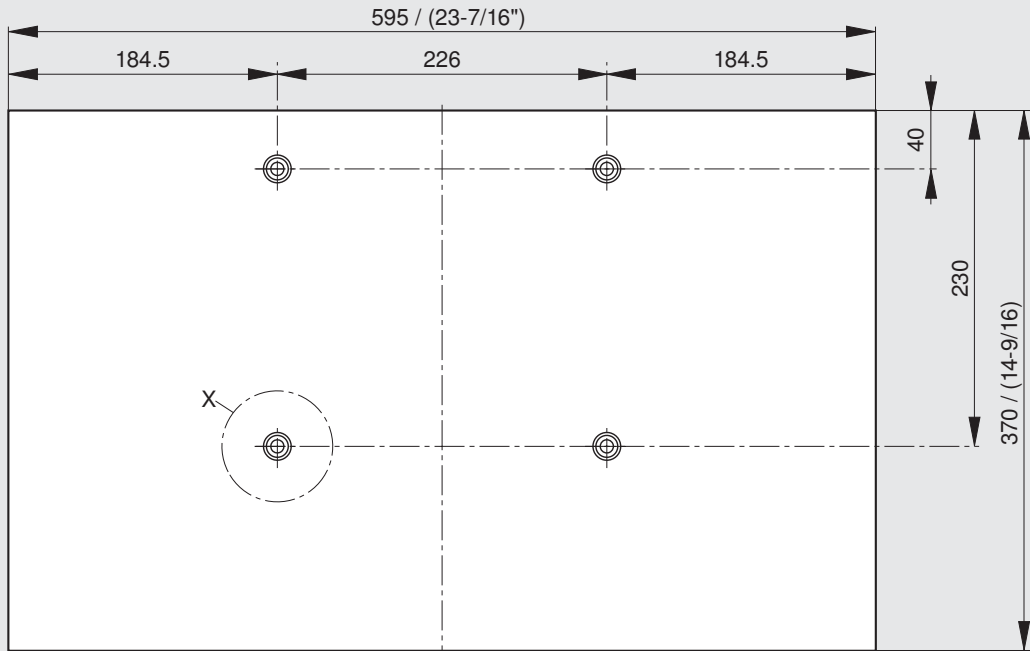

Note: all dimensions in millimeters

- If you are making your own work table, use plywood or laminated wood.
- In addition, please use the bolts supplied for attaching the work table.

10.1 - Electrical diagram 1Φ 110 V 60 Hz

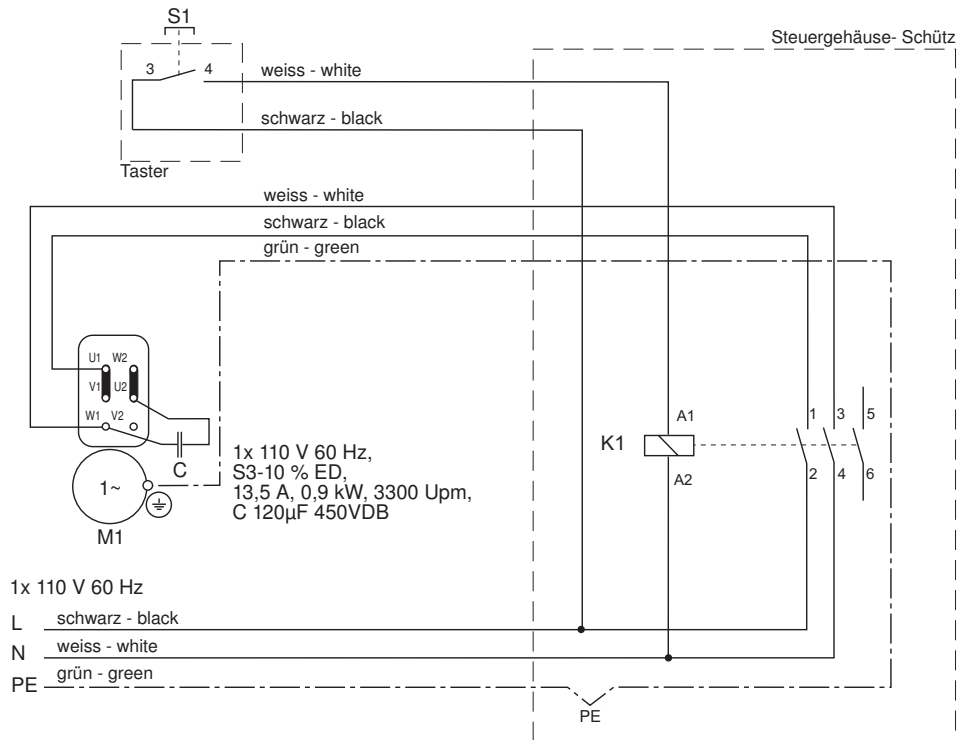

1) General data

- Voltage: see serial tag
- Current: see serial tag
- Connected load
- Motor: see serial tag
- RPM: see serial tag

Important: Provide a 15 A circuit breaker.

3) Max. work piece thickness:

- boring only 1-3/4" (45 mm)
- inserting see BLUM complete catalogue

5) Max. boring diameter

- 1-3/8" (35 mm) diameter

2) Weight and measurements

Weight: 82 lbs (37 kg)

Dimensions: Height = 36.75" (933 mm)
 Width = 24" (610 mm)
 Length = 20.875" (530 mm)

4) Max. boring distance

- Boring distance center spindle: 0 to 2-3/4" (0 to 70 mm)

6) Accessories

- For accessories see BLUM complete catalogue

USA
Blum Inc.
Functional Hardware Mfg.
For Kitchen Cabinets
7733 Old Plank Rd.
Stanley NC 28164
USA
Toll-free: 1-800-438-6788
Tel.: 1-704-827-1345
Fax: 1-704-827-0799
sales.us@blum.com

