

### FEATURED MODEL

440220 DIAMOND EQUAL DOUBLE Drop-in ANTHRACITE

### ADDITIONAL MODELS

- 440222 DIAMOND EQUAL DOUBLE Drop-in BISCUIT
- 440219 DIAMOND EQUAL DOUBLE Drop-in METALLIC GRAY
- 440218 DIAMOND EQUAL DOUBLE Drop-in CAFE BROWN
- 441285 DIAMOND EQUAL DOUBLE Drop-in TRUFFLE
- 441217 DIAMOND EQUAL DOUBLE Drop-in BISCOTTI
- 440221 DIAMOND EQUAL DOUBLE Drop-in WHITE
- 441466 DIAMOND EQUAL DOUBLE Drop-in CINDER

**Versatile dual deck design can be installed as a drop-in or undermount.**

### FEATURES

- Required Outside Cabinet for drop-in installation: 33"
- Required Cabinet for undermount installation: 35"
- 80% solid granite
- Heat resistant up to 536°F
- Unsurpassed cleanability backed by industry leading 7 patents!
- Resistant to scratches, stains and all household acids and alkali solutions
- Template provided
- Under mount clips NOT included
- Limited lifetime warranty

### OPTIONAL ACCESSORIES

- Cutting Board (Fits Drop-In sink only) - 440229
- Colander - 440492
- Stainless Steel Sink Grid Right - 221008
- Stainless Steel Sink Grid Right - 221009

### CODE/STANDARDS COMPLIANCE

- ANSI Z124.6-97
- IAPMO/UPC listed

### WARRANTY

BLANCO'S SILGRANIT II Series sinks feature a LIMITED LIFETIME WARRANTY to be free of all manufacturing defects under normal use. See our complete warranty for details.

While BLANCO endeavors to provide accurate information, all dimensions are nominal, cannot be guaranteed, and are subject to change or cancellation. BLANCO assumes no responsibility for use of superseded or voided specifications.

### JOB INFORMATION

Job Name: \_\_\_\_\_

Contact: \_\_\_\_\_

Date Specified: \_\_\_\_\_

Specifier: \_\_\_\_\_

Contractor: \_\_\_\_\_



Model 440220 shown

### NOMINAL DIMENSIONS

OVERALL	CUTOUT SIZE	BOWL DEPTH		DRAIN DIAMETER
		LEFT	RIGHT	
33 x 22	32-1/4 x 21-1/4	9-1/2	9-1/2	3-1/2

DXF cutout templates (Undermount and Drop-In version) available on our web site.

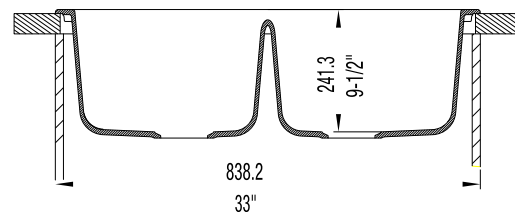
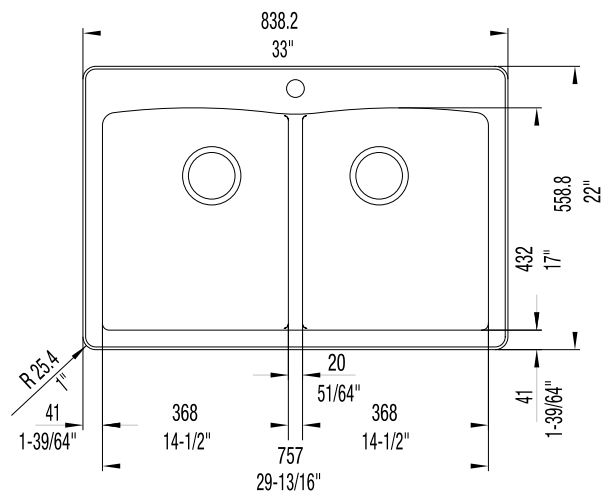

### KNOCKOUT HOLE LOCATIONS

Pre-drilled for single hole faucet.

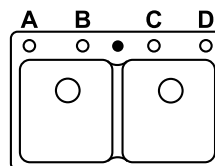

Distance between A & B - 10"  
 Distance between C & D - 10"

### BLANCO AMERICA

800.451.5782

[www.blancoamerica.com](http://www.blancoamerica.com)

© 2011 BLANCO  
 2/11