

BLANCO ATURA

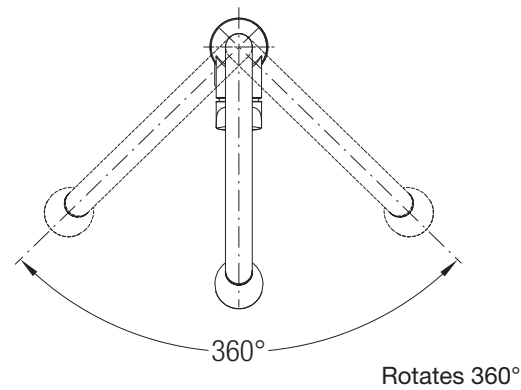
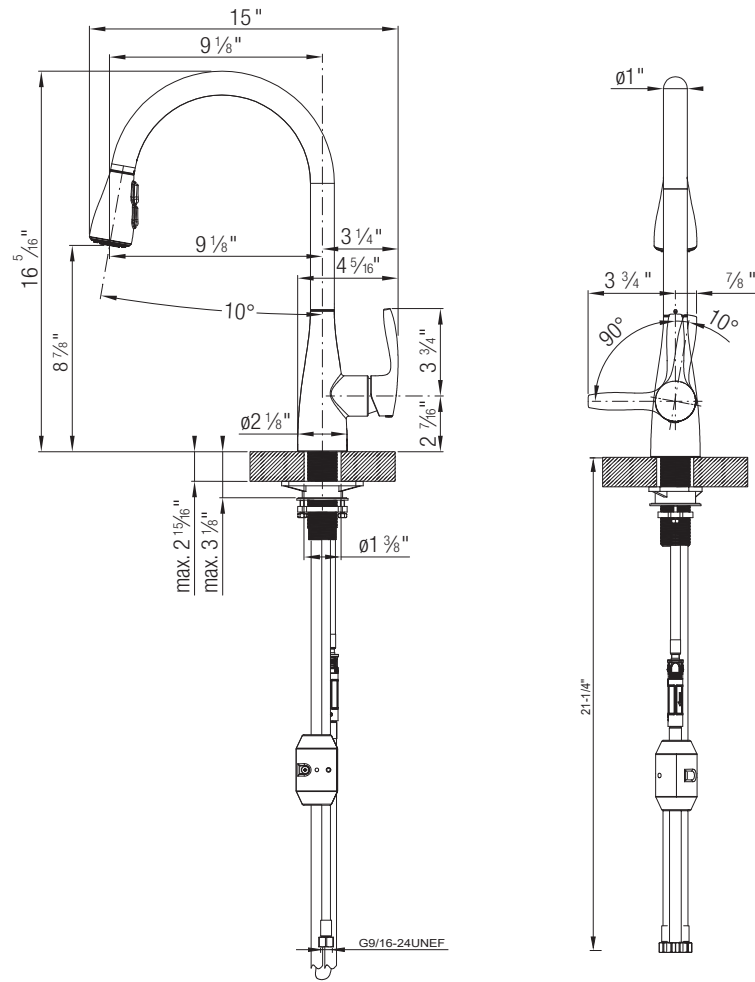

BLANCO CANADA INC. and BLANCO AMERICA INC. are subject to the terms below pleased to offer a:

- Limited Lifetime Warranty with all BLANCO faucets used in interior single-family domestic installations;
- Limited 10 Year Warranty with all BLANCO faucets used in interior multi-residential and rental housing installations; and
- Limited 5 Year Warranty with all BLANCO faucets used for commercial purposes in interior installations.

BLANCO warrants its faucets to be free from all proven manufacturing defects in material and workmanship. BLANCO will repair or replace at no charge, excluding labor and freight, any faucet supplied by BLANCO that is proven to be defective under normal use.

LIMITED WARRANTY FOR COMPONENTS SUBJECT TO ORDINARY WEAR AND TEAR

- Limited 10 Year Warranty for all (i) mechanical components such as handles, cartridges, sprayheads, spray hoses, aerators and (ii) electronic faucets and components (batteries are excluded) used in interior single-family domestic installations and interior multi-residential and rental housing installations.
- Limited 5 Year Warranty for all (i) mechanical components such as handles, cartridges, spray heads, spray hoses, aerators and (ii) electronic faucets and components (batteries are excluded) used for commercial purposes in interior installations.

WARRANTY EXCLUSIONS AND OTHER TERMS

BLANCO shall not be liable in case of: (A) improper installation or modification, damages resulting from abuse, such as heavy impact or dropped objects, improper care or maintenance, improper applications (such as exposure to corrosive chemicals, photographic solutions, etc.), and any modifications made to the product after it left BLANCO premises; (B) wear and tear, including chips, scratches and stains that can occur under normal use; or (C) loss or damage to any person or property whatsoever resulting from a defective product.

All transportation costs to and from the point of purchase, labor, removal and reinstallation will be the responsibility of the purchaser.

For greater clarity, accessories that accompany the sink (strainers, waste fittings, waste chutes etc.) are under separate product-specific warranties.

TO THE EXTENT NOT PROHIBITED BY LAW, NO OTHER WARRANTY, WHETHER EXPRESS, IMPLIED, OR STATUTORY, INCLUDING ANY WARRANTY OF MERCHANTABILITY OR FITNESS FOR A PARTICULAR PURPOSE SHALL BE DEEMED TO EXIST IN CONNECTION WITH ANY OF THE GOODS OR SERVICES SUPPLIED HEREUNDER, AND ALL IMPLIED WARRANTIES, INCLUDING ANY IMPLIED WARRANTIES FOR A PERIOD GREATER THAN THE WARRANTY PERIOD CONTAINED IN BLANCO'S LIMITED WARRANTY, ARE HEREBY EXCLUDED. BLANCO SHALL NOT BE LIABLE FOR ANY INDIRECT, INCIDENTAL, SPECIAL OR CONSEQUENTIAL DAMAGES IN ANY WAY RELATED TO THE GOODS OR SERVICES SUPPLIED HEREUNDER. THE REMEDIES DESCRIBED IN THIS WARRANTY ARE YOUR SOLE AND EXCLUSIVE REMEDIES AND OUR ENTIRE LIABILITY FOR ANY BREACH OF THIS WARRANTY.

THIS WARRANTY GIVES YOU SPECIFIC LEGAL RIGHTS, AND YOU MAY ALSO HAVE OTHER RIGHTS WHICH VARY FROM JURISDICTION TO JURISDICTION. SOME PROVINCES, STATES OR OTHER JURISDICTIONS DO NOT ALLOW THE EXCLUSION OR LIMITATION OF IMPLIED WARRANTIES OR OF INCIDENTAL OR CONSEQUENTIAL DAMAGES, SO THE ABOVE LIMITATIONS OR EXCLUSIONS RELATING TO IMPLIED WARRANTIES, OR INCIDENTAL OR CONSEQUENTIAL DAMAGES MAY NOT APPLY TO YOU.

This warranty applies only to the products sold and installed in Canada and the U.S.A. Blanco Canada Inc. will be responsible for this warranty for products sold and installed in Canada and Blanco America, Inc. will be responsible for this warranty for products sold and installed in the U.S.A. This warranty supersedes all previous warranties for any BLANCO sink, faucet, accessory, soap dispenser, and repair part in the U.S.A and Canada. This is BLANCO's exclusive written warranty and the warranty is not transferable without the prior written consent of Blanco, in its sole and absolute discretion.

To obtain warranty service, please visit the support section on our website www.blanco.com.

BLANCO ATURA



124 011 09/2022

BLANCO

www.blanco.com
cc.na@blanco.com

BLANCO America Inc.
110 Mount Holly Bypass,
Lumberton, New Jersey 08048
Toll free phone: 1-800-451-5782
Toll free fax: 1-800-213-1963

BLANCO Canada Inc.
100 Corporation Drive
Brampton, Ontario L6S 6B5
Toll free phone: 1-877-425-2626
Toll free fax: 1-877-825-2626

max. temperature
70 °C (158 °F)

max. pressure
10 bars (145 psi)

After installation, please pass these instructions on to the end customer.



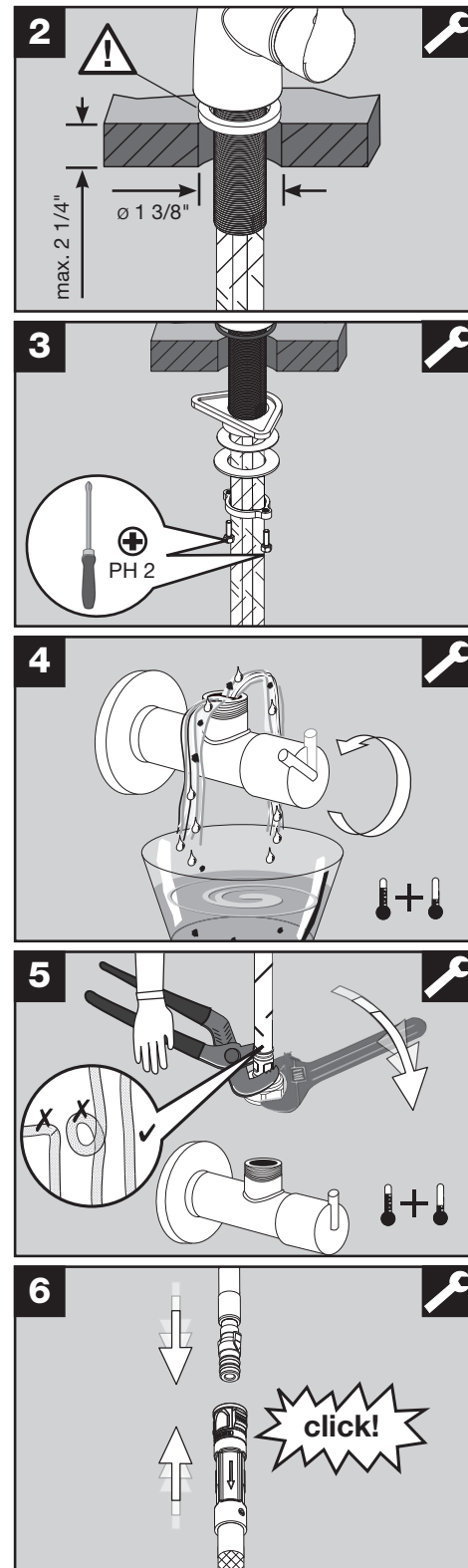
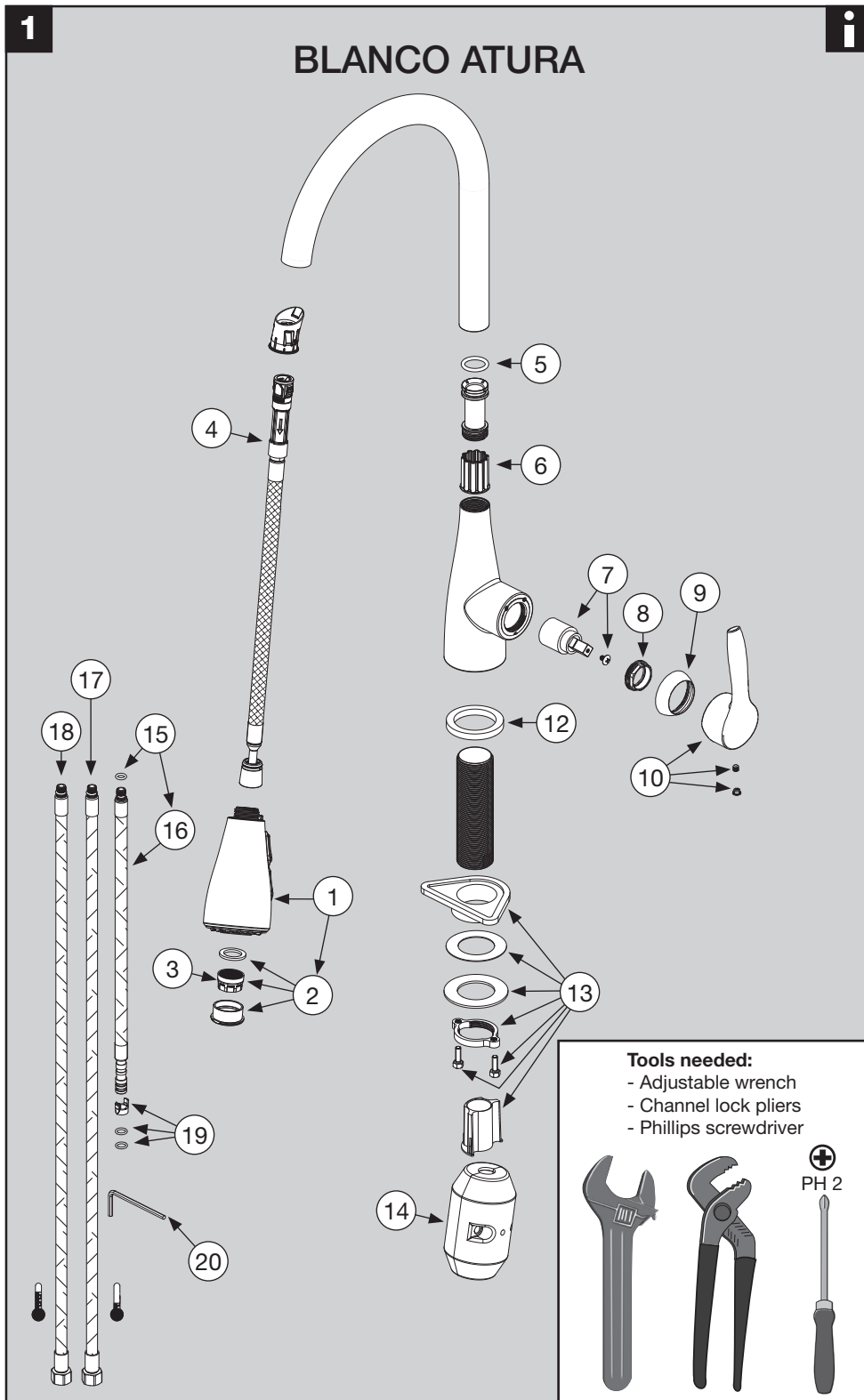

INSTALLATION

Place faucet through 1-3/8" hole. Take care that the sealing ring (12) on the upper sink/countertop side is in its correct position.

Secure faucet to sink/countertop using mounting hardware (13). Tighten screws on the mounting nut until the faucet is secure.

The proper sequence of hardware is: triangular reinforcement base, rubber washer, metal washer, mounting nut.

Before connecting supply lines to the water valves, flush each water valve to remove dirt and particles that can affect the functioning of the faucet and void warranty.

Connect hot supply line (18 – red) and cold supply line (17 – blue) to hot and cold water valves.

Hold line while tightening nut to prevent line from twisting. Do not over tighten.

Slide the spray hose (4) over the supply line (16) until it clicks into place.

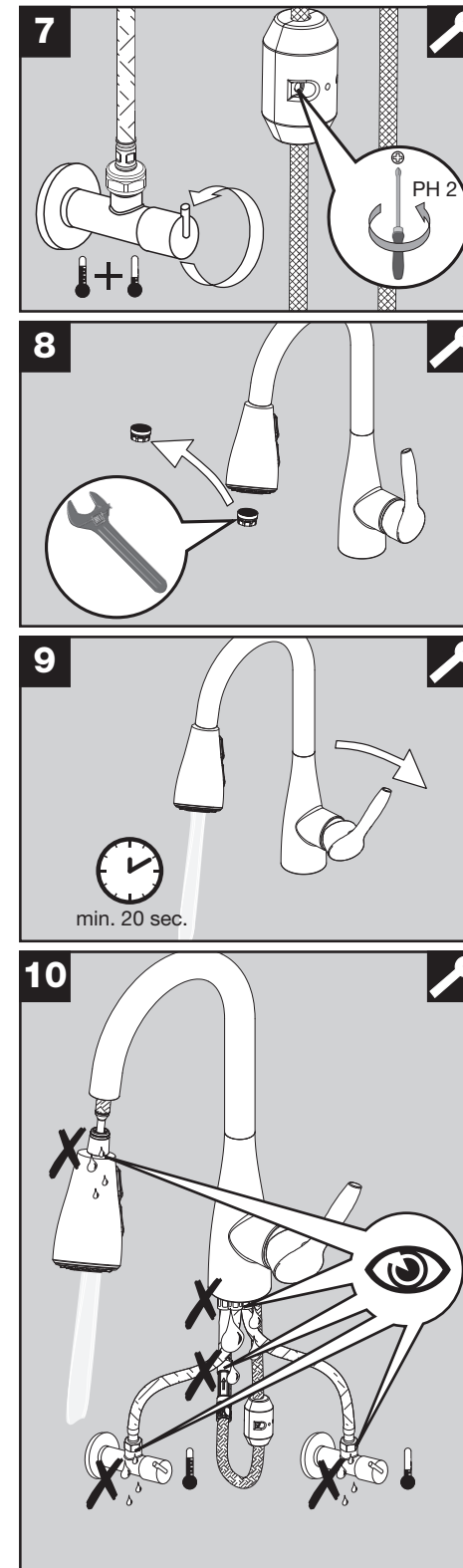

Attach the weight (14) to the spray hose (4) using screws supplied. Weight should be attached a few inches from the bottom of the hose loop.

Open water valves slowly.

Remove aerator (2).

Open the water lever and flush for at least 20 seconds the lines and the faucet.

Double check all connections for leaks.

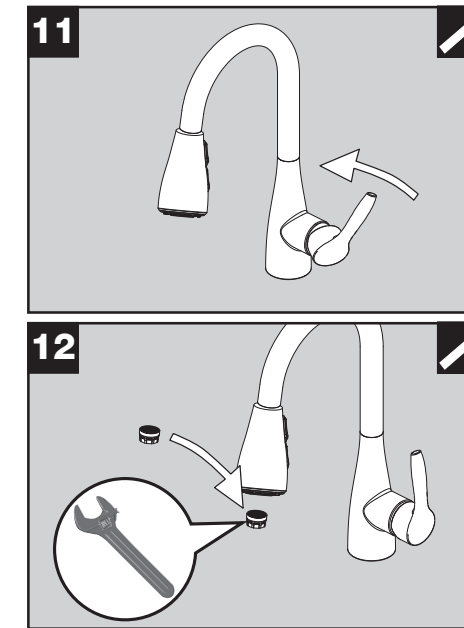

Shut off the water valve.

Reinstall the aerator.