

# AXOR®

## hansgrohe

<b>DE</b>	Gebrauchsanleitung / Montageanleitung	2
<b>FR</b>	Mode d'emploi / Instructions de montage	2
<b>EN</b>	Instructions for use / assembly instructions	3
<b>IT</b>	Istruzioni per l'uso / Istruzioni per Installazione	3
<b>ES</b>	Modo de empleo / Instrucciones de montaje	4
<b>NL</b>	Gebruiksaanwijzing / Handleiding	4
<b>DK</b>	Brugsanvisning / Monteringsvejledning	5
<b>PT</b>	Instruções para uso / Manual de Instalação	5
<b>PL</b>	Instrukcja obsługi / Instrukcja montażu	6
<b>CS</b>	Návod k použití / Montážní návod	6
<b>SK</b>	Návod na použitie / Montážny návod	7
<b>ZH</b>	用户手册 / 组装说明	7
<b>RU</b>	Руководство пользователя / Инструкция по монтажу	8
<b>HU</b>	Használati útmutató / Szerelési útmutató	8
<b>FI</b>	Käyttöohje / Asennusohje	9
<b>SV</b>	Brugsanvisning / Monteringsanvisning	9
<b>LT</b>	Vartotojo instrukcija / Montavimo instrukcijos	10
<b>HR</b>	Upute za uporabu / Uputstva za instalaciju	10
<b>TR</b>	Kullanım kılavuzu / Montaj kılavuzu	11
<b>RO</b>	Manual de utilizare / Instrucțiuni de montare	11
<b>EL</b>	Οδηγίες χρήσης / Οδηγία συναρμολόγησης	12
<b>SL</b>	Navodilo za uporabo / Navodila za montažo	12
<b>ET</b>	Kasutusjuhend / Paigaldusjuhend	13
<b>LV</b>	Lietošanas pamācība / Montāžas instrukcija	13
<b>SR</b>	Uputstvo za upotrebu / Uputstvo za montažu	14
<b>NO</b>	Brugsanvisning / Montasjeveiledning	14
<b>BG</b>	Инструкция за употреба / Ръководство за монтаж	15
<b>SQ</b>	Udhëzuesi i përdorimit / Udhëzime rreth montimit	15
<b>AR</b>	دليل الاستخدام / تعليمات التجميع	16



**Starck Organic**  
42737000



**Starck Organic**  
42706000  
42708000  
42730000

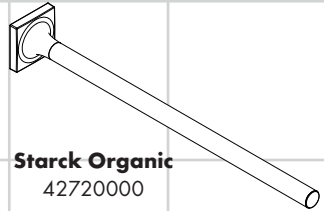

**Starck Organic**  
42720000

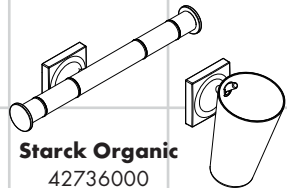

**Starck Organic**  
42736000

**Starck Organic**  
42734000

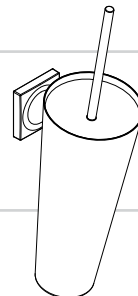



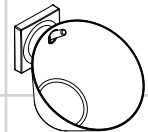

**Starck Organic**  
42733000



**Starck Organic**  
42735000



## Sicherheitshinweise

-  Bei der Montage müssen zur Vermeidung von Quetsch- und Schnittverletzungen Handschuhe getragen werden.
-  Bestimmungsgemäßer Gebrauch des Haltegriffes 42730000: Der Haltegriff ist kein medizinisches Produkt, er ist nicht für körperlich beeinträchtigte Personen geeignet, sondern nur für den privaten Bereich bestimmt.
-  Es darf ausschließlich nur der Haltegriff zum Festhalten benutzt werden, die übrigen Produkte sind für diesen Einsatzzweck nicht geeignet.
-  Die ordnungsgemäße Befestigung und der feste Sitz der montierten Produkte ist in periodischen Abständen (jährlich) zu überprüfen.

## Montagehinweise

- Bei der Montage des Produktes durch qualifiziertes Fachpersonal ist darauf zu achten, dass die Befestigungsfläche im gesamten Bereich der Befestigungsplan ist (keine vorstehenden Fugen oder Fliesenversatz), der Wandaufbau für eine Montage des Produktes geeignet ist und keine Schwachstellen aufweist. Die beigelegten Schrauben und Dübel sind nur für Beton geeignet. Bei anderen Wandaufbauten sind die Herstellerangaben des Dübelherstellers zu beachten.
- Vor der Montage muss das Produkt auf Transportschäden untersucht werden. Nach dem Einbau werden keine Transport- oder Oberflächenschäden anerkannt.

## Symbolerklärung



Kein essigsäurehaltiges Silikon verwenden!



**Maße** (siehe Seite 21)







**Serviceteile** (siehe Seite 23)



**Reinigung**

siehe beiliegende Broschüre.

## Consignes de sécurité

-  Lors du montage, porter des gants de protection pour éviter toute blessure par écrasement ou coupure.
-  Utilisation conforme de la poignée 42730000 : la poignée n'est pas un ustensile médical et ne convient pas aux handicapés physiques ; elle est seulement destinée au domaine privé.
-  N'utiliser que la poignée pour se retenir, les autres produits ne convenant pas à cette utilisation.
-  Vérifier à intervalles réguliers (une fois par an) la fixation correcte et la bonne assise des produits montés

## Instructions pour le montage

- Lors du montage du produit par un ouvrier qualifié, il faut faire attention à ce que la surface de fixation soit plane sur toute son étendue (aucun dépassement de joint ni de carrelage), que la construction de la paroi soit adaptée à l'installation du produit et surtout ne présente aucun point faible. Les vis et les chevilles fournies sont uniquement appropriées au béton. Pour les autres constructions, il faudra tenir compte des préconisations du fabricant de cheville.
- Avant son montage, s'assurer que le produit n'a subi aucun dommage pendant le transport. Après le montage, tout dommage de transport ou de surface ne pourra pas être reconnu.

## Description du symbole



Ne pas utiliser de silicone contenant de l'acide acétique!



**Dimensions** (voir page 21)



**Pièces détachées** (voir page 23)







**Nettoyage**

voir la brochure ci-jointe.





## Safety Notes

-  Gloves should be worn during installation to prevent crushing and cutting injuries.
-  Intended use of the handle 42730000: The handle is not a medical product, it is not intended for physically impaired persons, but only for general private use.
-  Use only the handle for support, the remaining products are not intended to be used as supports.
-  Check the proper attachment and tight seating of the installed products periodically (annually).

## Installation Instructions

- Where the contractor mounts the product, he should ensure that the entire area of the wall to which the mounting plate is to be fitted, is flat (no projecting joints or tiles sticking out), that the structure of the wall is suitable for the installation of the product and has no weak points. The enclosed screws and dowels are only suitable for concrete. For another wall constructions the manufacturer's indications of the dowel manufacturer have to be taken into account.
- Prior to installation, inspect the product for transport damages. After it has been installed, no transport or surface damage will be honoured.

## Symbol description



Do not use silicone containing acetic acid!



**Dimensions** (see page 21)







**Spare parts** (see page 23)



**Cleaning**

see enclosed brochure.

## Indicazioni sulla sicurezza

-  Durante il montaggio, per evitare ferite da schiacciamento e da taglio bisogna indossare guanti protettivi.
-  Impiego conforme all'uso dell'impugnatura 42730000: L'impugnatura non è un prodotto medico, non è adatto per persone disabili, bensì è destinato solo nell'ambito privato.
-  Per tenersi deve essere utilizzato esclusivamente l'impugnatura, gli altri prodotti non sono adatti per questo scopo d'impiego.
-  Il fissaggio a regola d'arte e la sede fissa dei prodotti montati va controllato a intervallo periodico (annualmente).

## Istruzioni per il montaggio

- Quando il personale tecnico specializzato esegue il montaggio del prodotto è necessario assicurarsi che la superficie di fissaggio sia piana in tutta l'area di fissaggio (senza giunti sporgenti o spostamento delle piastrelle), che la struttura della parete sia adatta per il montaggio del prodotto e soprattutto che non ci siano dei punti deboli. Le viti e i tasselli in dotazione sono adatti solo per calcestruzzo. In caso di altre strutture della parete vanno osservare le indicazioni del produttore dei tasselli.
- Prima del montaggio è necessario controllare che non ci siano stati danni durante il trasporto. Una volta eseguito il montaggio, non verranno riconosciuti eventuali danni di trasporto o delle superfici.

## Descrizione simbolo



Non utilizzare silicone contenente acido acetico!



**Ingombri** (vedi pagg. 21)



**Parti di ricambio** (vedi pagg. 23)



**Pulitura**

vedi il prospetto accluso.





**Assembly**  
see page 17



**Montaggio**  
vedi pagg. 17



## Indicaciones de seguridad

-  Durante el montaje deben utilizarse guantes para evitar heridas por aplastamiento o corte.
-  Uso proyectado de la manilla 42730000: La manilla no es un producto médico, no es adecuado para personas con movilidad restringida sino destinada únicamente al ámbito privado.
-  Solo debe utilizarse exclusivamente la manilla para sujetarse, los demás productos no son adecuados para este uso.
-  Debe comprobarse en intervalos periódicos (anualmente) que los productos montados estén bien fijados y asentados.

## Indicaciones para el montaje

- En el momento del montaje del producto por parte de personal especializado y cualificado se deberá prestar una atención especial a que la superficie de fijación en toda el área de la fijación sea plana (sin juntas que sobresalen ni azulejos desplazados), que la estructura de la pared sea adecuada para un montaje del producto y que, ante todo, no presente puntos débiles. Los tornillos y tacos adjuntos son sólo apropiados para hormigón. En el caso de otras estructuras murales se deberán considerar las indicaciones del fabricante de tacos.
- Antes del montaje se debe examinarse el producto contra daños de transporte. Después de la instalación no se reconoce ningún daño de transporte o de superficie.

## Descripción de símbolos



No utilizar silicona que contiene ácido acético!



**Dimensiones** (ver página 21)







**Repuestos** (ver página 23)



**Limpiar**

ver el folleto adjunto.

## Veiligheidsinstructies

-  Bij de montage moeten ter voorkoming van knel- en snijwonden handschoenen worden gedragen.
-  Reglementair gebruik van de handgreep 42730000: de handgreep is geen medisch product, hij is niet geschikt voor personen met een lichamelijke handicap en alleen bestemd voor privaat gebruik.
-  Alleen de handgreep mag gebruikt worden om zich vast te houden, de overige producten zijn voor dat gebruiksdoeleinde niet geschikt.
-  De reglementaire bevestiging en de vaste zitting van de gemonteerde producten moet regelmatig (jaarlijks) gecontroleerd worden.

## Montage-instructies

- Bij de montage van het product door een vakkundige installateur moet men erop letten dat het bevestigingsoppervlak op één oppervlak zit (dus geen opvallende voegen of verspringende tegels), de wand geschikt is voor montage van producten en zeker geen zwakke plekken bevat. De bijgevoegde schroeven en duvels zijn alleen geschikt voor beton. Bei andere wandsoorten dient u te letten op de voorschriften van de fabrikant van de schroeven en duvels.
- Vóór de montage moet het product gecontroleerd worden op transportschade. Na de inbouw wordt geen transport- of oppervlakteschade meer aanvaard.

## Symboolbeschrijving



Gebruik geen zuurhoudende silicone!



**Maten** (zie blz. 21)



**Service onderdelen** (zie blz. 23)







**Reinigen**

zie bijgevoegde brochure.









### Sikkerhedsanvisninger

-  Ved monteringen skal der bruges handsker for at undgå kvæstelser og snitsår.
-  Formålstjenlig brug af håndtaget 42730000: Håndtaget er intet medicinsk produkt. Det er ikke beregnet til personer med handicap og kun til privat brug.
-  Man må udelukkende bruge håndtaget til at holde sig fast med. De øvrige produkter er ikke egnet til dette formål.
-  Den korrekte montering og position af monterede produkter skal kontrolleres i regelmæssige afstande (årligt).





### Monteringsanvisninger

- Ved montering er det vigtigt at sikre sig, at hele befæstigelsesfladen er plan (ingen ujævne fuger eller fliser), samt at væggen er egnet til montering af produktet og specielt, at væggen ikke har nogen svage punkter. De medfølgende skrue og dübler er kun egnet til beton. Ved anden vægopbygning bør producenten af dübler kontaktes for nærmere information.
- Før monteringen skal produktet kontrolleres for transportskader. Efter monteringen godkendes transportskader eller skader på overfladen ikke længere.

### Symbolbeskrivelse

-  Der må ikke benyttes eddikesyreholdig silikone!
-  **Målene** (se s. 21)
-  **Reserve dele** (se s. 23)
-  **Rengøring**  
se venligst den vedlagte brochure.





### Avisos de segurança

-  Durante a montagem devem ser utilizadas luvas de protecção, de modo a evitar ferimentos resultantes de entalamentos e de cortes.
-  Utilização adequada da pega 42730000: A pega não é nenhum produto do foro médico e não é adequado para pessoas com deficiências ou debilitações motoras. Esta destina-se apenas para a utilização privada.
-  Para se segurar ou apoiar só pode utilizar a pega, visto os outros produtos não serem adequados para esse fim.
-  A fixação e encaixe correctos dos produtos montados devem ser verificados periodicamente (anualmente).

### Avisos de montagem

- Durante a montagem do produto por técnicos qualificados, deve ter-se em atenção que a superfície de fixação seja plana em toda a área da fixação (sem juntas sobrepostas/salientes ou ladrilhos deslocados), que o dispositivo de montagem na parede seja adequado para uma montagem na parede e que este não apresente nenhuns pontos fracos. Os parafusos e buchas incluídos no volume de fornecimento são apenas adequados para betão. Para outros métodos de montagem na parede devem ser respeitadas as indicações do fabricante das buchas.
- Antes da montagem deve-se controlar o produto relativamente a danos de transporte. Após a montagem não são aceites quaisquer danos de transporte ou de superfície.





### Descrição do símbolo

-  Não utilizar silicone que contenha ácido acético!
-  **Medidas** (ver página 21)
-  **Peças de substituição** (ver página 23)
-  **Limpeza**  
consultar a seguinte brochura.





## Wskazówki bezpieczeństwa

-  Aby uniknąć zranień, takich jak zgniecenia czy przecięcia, podczas montażu należy nosić rękawice.
-  Użytkowanie uchwytu 42730000 zgodnie z przeznaczeniem: Uchwyt nie jest produktem medycznym, nie jest on przeznaczony dla osób niepełnosprawnych o utrudnionym poruszaniu się, lecz jedynie do użytku prywatnego.
-  Do trzymania się może być używany jedynie uchwyt; pozostałe produkty nie nadają się do tego celu.
-  W określonym czasie (co roku) należy sprawdzać właściwe zamocowanie i odpowiednie osadzenie zamontowanych produktów.

## Wskazówki montażowe

- Przy montażu produktu przez wykwalifikowany personel fachowy należy zważać na to, by powierzchnia mocowania na całym obszarze mocowania była równa (by nie było szczelin wzgl. wzajemnie przesuniętych płytek), rodzaj ściany nadawał się do montażu produktu i zwłaszcza, by nie było żadnych słabych stron. Umieszczone w dostawie śruby i kołki rozporowe są przeznaczone tylko do betonu. Przy innych rodzajach montażu ściannowego należy przestrzegać danych producenta kołków rozporowych.
- Przed montażem należy skontrolować produkt pod kątem szkód transportowych. Po montażu nie widać żadnych szkód transportowych ani szkód na powierzchni.

## Opis symbolu



Nie stosować silikonów zawierających kwas octowy!



**Wymiary** (patrz strona 21)







**Części serwisowe** (patrz strona 23)



**Czyszczenie**

patrz dołączona broszura.

## Bezpečnostní pokyny

-  Pro zabránění řezným zraněním a pohmožděním je nutné při montáži nosit rukavice.
-  Použití držáku 42730000 v souladu s určením: Držák není žádný medicínský produkt, není vhodný pro tělesně postižené osoby, je určen pouze pro soukromý sektor.
-  K držení se smí používat výlučně držák, ostatní produkty nejsou vhodné pro tento účel použití.
-  Upevnění podle předpisů a pevné usazení montovaných produktů je třeba kontrolovat v periodických časových intervalech (ročně).

## Pokyny k montáži

- Při montáži produktu kvalifikovaným odborným personálem je třeba dbát na to, aby upevňovací plochy byly v celém rozsahu upevnění rovné (žádné vyčnívající spáry nebo navzájem přesazené obklady), aby konstrukce stěny byla pro montáž produktu vhodná a zvláště aby v ní nebyla žádná slabá místa. Přiložené vruty a hmoždinky jsou vhodné pouze pro beton. Při jiných konstrukčních materiálech stěny je třeba se řídit údaji výrobce hmoždinek.
- Před montáží je třeba produkt zkontrolovat, zda nebyl při transportu poškozen. Po zabudování nebudou uznány žádné škody způsobené transportem nebo poškození povrchu.

## Popis symbolů



Nepoužívat silikon s obsahem kyseliny octové!



**Rozměry** (viz strana 21)



**Servisní díly** (viz strana 23)



**Čištění**

viz přiložená brožura.





## **Bezpečnostné pokyny**

- △ Pri montáži musíte nosiť rukavice, aby ste predišli pomliaždeninám a rezným poraneniam.
- △ Použitie držiaka 42730000 podľa určenia: Držiak nie je žiaden lekársky produkt, nie je vhodný pre telesne postihnuté osoby, je určený iba pre súkromný sektor.
- △ Na držanie sa smie používať výlučne držiak, ostatné produkty nie sú vhodné na tento účel použitia.
- △ Upevnenie podľa predpisov a pevné osadenie montovaných produktov treba kontrolovať v periodických časových intervaloch (ročne).

## **Pokyny pre montáž**

- Pri montáži produktu kvalifikovaným odborným personálom je nutné dbať na to, aby upevňovacie plochy boli v celom rozsahu upevnenia rovné (žiadne vyčnievajúce škáry alebo navzájom predsažené obklady), aby konštrukcia steny bola pre montáž produktu vhodná a zvlášť aby v nej neboli žiadne slabé miesta. Priložené vruty a hmoždinky sú vhodné len pre betón. Pri iných konštrukčných materiáloch steny je nutné riadiť sa údajmi výrobcu hmoždiniek.
- Pred montážou musíte produkt skontrolovať, či nebol počas transportu poškodený. Po zabudovaní nebudú uznané žiadne škody spôsobené transportom alebo poškodenia povrchu.

## **Popis symbolov**

 Nepoužívať silikón s obsahom kyseliny octovej!

 **Rozmery** (viď strana 21)

 **Servisné diely** (viď strana 23)

 **Čistenie**  
nájdate v priloženej brožúre.

## **安全技巧**

- △ 装配时为避免挤压和切割受伤，必须戴上手套。
- △ 按规定使用握柄 42730000：握柄乃非医疗产品，它不适用于身体受到损害的人员，而只适用于私人范畴。
- △ 握柄只用于握持，其它产品不适用于此项使用用途。
- △ 应定期（每年）检查已装配好的产品是否正常固定和固定定位。

## **安装提示**

- 在安装产品的位置，安装人员必须确保安装面的墙面是平的（没有突出物或瓷砖没有突起），墙体结构适合产品的安装并没有弱点。包装内的膨胀螺丝只适用于混凝土墙体。对于其他墙体结构必须咨询膨胀螺丝生产商的建议。
- 安装前必须检查产品是否受到运输损害。安装后将不认可运输损害或表面损伤。

## **符号说明**

 请勿使用含有乙酸的硅！

 大小 (参见第 21 页)

 备用零件 (参见第 23 页)

 清洗  
附有小手册





**Montáž**  
**viď strana 17**



**安装**  
**参见第 17 页**



## Указания по технике безопасности

-  Во время монтажа следует надеть перчатки во избежание прищемления и порезов.
-  Применение по назначению рукоятки 42730000: рукоятка не является медицинским оборудованием, она не предназначена для использования людьми с физическими недостатками, предназначена только для частного использования.
-  Для фиксации разрешается использовать исключительно рукоятку, остальные изделия непригодны для этой цели.
-  Надлежащее крепление и плотность посадки установленных изделий следует проверять регулярно (ежегодно).

## Указания по монтажу

- При монтаже изделия квалифицированным персоналом необходимо следить за тем, чтобы, поверхность крепления была плоской во всей зоне крепления (без выступающих швов или смещения плитки), структура стен подходила для монтажа изделия и, в частности, не имела слабых мест. Прилагаемые винты и дюбели предназначены только для бетона. При других типах стен необходимо соблюдать указания производителей дюбелей.
- Перед монтажом следует проверить изделие на предмет повреждений при перевозке. После монтажа претензии о возмещении ущерба за повреждения при перевозке или повреждения поверхностей не принимаются.

## Описание символов



Не применяйте силикон, содержащий уксусную кислоту.



**Размеры** (см. стр. 21)







**Комплект** (см. стр. 23)



**Очистка**

см прилагаемая брошюра

## Biztonsági utasítások

-  A szerelésnél a zúzódások és vágási sérülések elkerülése érdekében kesztyűt kell viselni.
-  A 42730000 kapaszkodó rendeltetésszerű használata: A kapaszkodó nem orvosi termék, nem alkalmas testileg sérült személyek számára, hanem csak privát használatra szolgál.
-  Kapaszkodáshoz kizárólag csak a kapaszkodót szabad használni, a további termékek nem alkalmasak ilyen jellegű használatra.
-  A felszerelt termékek szabályszerű rögzítését és szilárd elhelyezkedését rendszeres időközönként (évente) ellenőrizni kell.

## Szerelési utasítások

- Miközben szakképzett szakember végzi a termék felszerelését, ügyelni kell arra, hogy a rögzítési felületek a rögzítési terület teljes egészén síkok (nincsenek kiálló fugák vagy csempeszélek), a fal felépítése alkalmas a termék felszereléséhez, és különösképpen, hogy nincsenek benne gyenge pontok. A mellékelt csavarok és dübelek csak betonhoz alkalmasak. Egyéb falazatoknál figyelembe kell venni a dübelgyártó gyártói utasításait.
- A szerelés előtt ellenőrizni kell, hogy a terméknek nincs-e szállítási sérülése. Beépítés után a szállítási- vagy felületi sérüléseket nem ismerik el.

## Szimbólumok leírása



Ne használjon ecetsavtartalmú szilikon!



**Méretet** (lásd a 21. oldalon)



**Tartozékok** (lásd a 23. oldalon)



**Tisztítás**





lásd a mellékelt brosúrát.







## Turvallisuusohjeet

-  Asennuksessa on käytettävä käsineitä puristumien ja viiltojen aiheuttamien tapaturmien estämiseksi.
-  Kahvan 42730000 tarkoituksenmukainen käyttö: Kahva ei ole lääkinällinen tuote. Se ei sovi ruumiillisesti rajoitteisten henkilöiden käyttöön, vaan se on tarkoitettu käytettäväksi yksityistiloissa.
-  Vain kahvaa saa käyttää kiinnittämiseen, muut tuotteet eivät sovi käytettäväksi siihen tarkoitukseen.
-  Asennettujen tuotteiden asianmukainen kiinnitys ja tiukkuus on tarkastettava säännöllisin väliajoin (vuosittain).

## Asennusohjeet

- Kun pätevä ammattihenkilöstö suorittaa tuotteen asennusta, on huomioitava, että kiinnityspinta on koko kiinnityksen alueella tasainen (ei ulkonevia saumoja tai laattojen tasomuutoksia) ja, että seinän rakenne soveltuu tuotteen asentamiseen eikä siinä ole heikkoja kohtia. Mukana olevat kiinnitysruuvit ja kiinnitysankkurit soveltuvat betoniin kiinnittämiseen. Kiinnitettäessä tuotetta muihin seinärakenteisiin, noutata kiinnittimien valmistajan ohjeita.
- Ennen asennusta on tarkastettava tuotteen mahdolliset kuljetusvahingot. Asennuksen jälkeen kuljetus- ja pintavaurioita ei hyväksytä.

## Merkin kuvaus





 Älä käytä etikahappopitoista silikoniala

 **Mitat** (katso sivu 21)

 **Varaosat** (katso sivu 23)

 **Puhdistus**  
katso oheinen esite

## Säkerhetsanvisningar

-  Handskar ska bäras under monteringsarbetet så att man kan undvika kläm- och skärskadorgen werden.
-  Avsedd användning av handtag 42730000: Handtaget är ingen medicinsk produkt och det är inte lämpligt för handikappade utan endast avsett för privat användning.
-  Det är bara handtaget som får användas till att hålla fast sig i. Övriga produkter är inte lämpliga till detta.
-  Alla monterade produkter ska kontrolleras regelbundet (varje år) så att de sitter fast ordentligt.

## Monteringsanvisningar

- När kvalificerad fackpersonal monterar produkten är det viktigt att tänka på att monteringsytan är plan i alla delar av arbetsytan (inga fogar som sticker ut eller klinkerförskjutningar), att väggkonstruktionen passar till monteringen av produkten samt att den inte har svaga punkter. Medföljande skruvar och plugg är endast avsedda för betong. Vid andra väggkonstruktioner skall anvisningarna från pluggtillverkaren beaktas.
- Det måste undersökas om produkten har transportskador innan den monteras. Efter monteringen accepteras inga transport- eller ytskiktsskador.

## Symbolförklaring

 Använd inte silikon som innehåller ättiksyra!

 **Måtten** (se sidan 21)





 **Reservdelar** (se sidan 23)

 **Rengöring**  
se den medföljande broschyren









## Saugumo technikos nurodymai

-  Apsaugai nuo užspaudimo ir įsijovavimo montavimo metu mūvėkite pirštines.
-  Rankenos naudojimas pagal paskirtį 42730000: rankena – tai nemedicininės paskirties produktas, ji netinka žmonėms su kūno pažeidimais; naudojama tik asmeninėje erdvėje.
-  Fiksuoti reikia tik su rankena, kiti gaminiai šiam tikslui nepritaikyti.
-  Gaminių pritvirtinimo teisingumą ir patikimumą būtina periodiškai (kasmet) tikrinti.

## Sigurnosne upute

-  Prilikom montaže se radi sprječavanja prignječjenja i posjekotina moraju nositi rukavice.
-  Namjenska upotreba drška 42730000: Držak nije medicinski proizvod i nije prikladan za primjenu od strane tjelesno hendikepiranih osoba, već je namijenjen isključivo za upotrebu u privatnom okruženju.
-  Za držanje se smije koristiti isključivo držak, svi ostali proizvodi su za tu svrhu neprikladni.
-  U redovitim vremenskim razmacima (jednom godišnje) valja provjeravati propisnu pričvršćenost i stabilnost postavljenih proizvoda.

## Montavimo instrukcija

- Montuojant produktą, specialistas privalo įsitikinti, kad sienos plotas, prie kurio dedama montavimo plokštė, yra lygus (jokių plytelių ar kitų nelygumų), kad sienos struktūra yra pritaikyta produkto montavimui ir neturi jokių silpnų vietų. Pakuotėje esantys varžtai ir kaiščiai yra skirti tik betonui. Esant kitokiai sienai, varžtus ir kaiščius reikia rinktis pagal paskirtį.
- Prieš montuojant būtina patikrinti, ar gaminyje nebuvo pažeistas transportavimo metu. Sumontavus pretenzijos dėl transportavimo ir paviršiaus pažeidimų nepriimamos.

## Upute za montažu

- Kada proizvod montira kvalificirano stručno osoblje treba paziti da čitava površina na koju se učvršćuje bude ravna (bez istaknutih fuga ili krivljenja pločica), da je zidna konstrukcija primjerena montaži proizvoda te osobito da nema slabih mjesta. Priloženi vijci i moždanci prikladni su samo za beton. Kod drugih zidnih nadgradnji treba obratiti pažnju na navode proizvođača moždanika.
- Prije montaže mora se provjeriti je li proizvod oštećen prilikom transporta. Nakon ugradnje se ne priznaju nikakve reklamacije koje se odnose na površinska i transportna oštećenja.

## Simbolio aprašymas



Nenaudokite silikono, kurio sudėtyje yra acto rūgšties!



**Išmatavimai** (žr. psl. 21)



**Atsarginės dalys** (žr. psl. 23)



**Valymas**

žr. pridedamoje brošiūroje.

## Opis simbola



Nemojte koristiti silikon koji sadrži octenu kiselinu!



**Mjere** (pogledaj stranicu 21)



**Rezervni djelovi** (pogledaj stranicu 23)



**Čišćenje**

se u priloženoj brošiuri.





### ! Güvenlik uyarıları

- ⚠ Montaj esnasında ezilme ve kesilme gibi yaralanmaları önlemek için eldiven kullanılmalıdır.
- ⚠ Tutamak 42730000'in kullanım amacı: Tutamak tıbbi bir ürün olmadığından bedensel engelli kişiler için uygun olmayıp, sadece kişisel kullanım içindir
- ⚠ Tutunmak için sadece tutamak kullanılabilir, diğer ürünler bu kullanıma uygun değildir.
- ⚠ Monte edilmiş ürünlerin talimatlara uygun sabitliği ve sıkı duruşu düzenli aralıklarla (yıllık) kontrol edilmelidir.

### Montaj açıklamaları

- Müteahhit, ürünü monteleyeceği yer, yani montaj plakasının monte edileceği duvar alanının tümü düz (herhangi bir eklem yerinin ya da duvar fayansının çıkıntısıyla) engellenmemiş, yapısı ürünü montelemeye uygun bir şekilde ve herhangi zayıf noktası olamamasını sağlamalıdır. Kaplı vidalar ve çubuklar sadece beton için uygundur. Başka duvar yapıları için, imalatçının çubuk imal edenin belirttiği hususlar dikkate alınmalıdır.
- Montaj işleminden önce ürün nakliye hasarları yönünden kontrol edilmelidir. Montaj işleminden sonra nakliye veya yüzey hasarları için sorumluluk üstlenilmemektedir.

### Simge açıklaması



Asetik asit içeren silikon kullanmayın!



**Ölçüleri** (Bakınız sayfa 21)



**Yedek Parçalar** (Bakınız sayfa 23)



**Temizleme**

birlikte verilen broşür

### ! Instrucțiuni de siguranță

- ⚠ La montare utilizați mănuși pentru evitarea contuziunilor și tăierii mâinilor.
- ⚠ Utilizarea mânerului de sprijin 42730000 conform destinației: Mânerul de sprijin nu este un produs medicinal, nefiind potrivit pentru persoanele cu dizabilități fizice, ci doar pentru a fi utilizat în domeniul privat
- ⚠ Utilizați exclusiv mânere de sprijin pentru a vă sprijini, celelalte produse nu sunt potrivite pentru a fi utilizate cu acest scop.
- ⚠ Fixarea corespunzătoare și poziția fixă a produselor montate trebuie verificate la intervale regulate (anual).

### Instrucțiuni de montare

- La montarea produsului de către un personal calificat trebuie să fiți atenți ca suprafața, unde se fixează produsul să fie plată pe toată suprafața utilizată (să nu existe rosturi sau faianțe proeminente), peretele să fie adecvat pentru montarea produsului și să nu există zone de rezistență redusă. Șuruburile și diblurile livrate sunt potrivite pentru ziduri de beton. La alte tipuri de zid respectați instrucțiunile producătorului diblului utilizat.
- Înainte de instalare verificați, dacă produsul prezintă deteriorări de transport. După instalare garanția nu acoperă deteriorările de transport și cele de suprafață.

### Descrierea simbolurilor



Nu utilizați silicon cu conținut de acid acetic!



**Dimensiuni** (vezi pag. 21)



**Piese de schimb** (vezi pag. 23)



**Curățare**

vezi broșura alăturată.

**Montajı**  
**Bakınız sayfa 17**



**Montare**  
**vezi pag. 17**



## Υποδειξεις ασφαλείας

- ⚠ Για να αποφύγετε τραυματισμούς κατά τη συναρμολόγηση πρέπει να φοράτε γάντια.
- ⚠ Ενδεξιγμένη χρήση της λαβής 42730000: Η λαβή δεν είναι ιατρικό προϊόν και δεν είναι κατάλληλη για άτομα με ειδικές ανάγκες, διότι έχει σχεδιαστεί μόνο για οικιακή χρήση.
- ⚠ Μπορεί να χρησιμοποιηθεί αποκλειστικά για κράτημα μόνο η λαβή. Τα υπόλοιπα προϊόντα είναι ακατάλληλα για τη χρήση αυτή.
- ⚠ Θα πρέπει να ελέγχετε ανά διαστήματα (ετησίως) αν η στερέωση εξακολουθεί να είναι επαρκής και αν τα τοποθετημένα προϊόντα σπηρίζονται καλά.

## Varnostna opozorila

- ⚠ Pri montaži je treba nositi rokavice, da se preprečijo poškodbe zaradi zmečkanja ali urezov.
- ⚠ Namenska uporaba držalnega ročaja 42730000: držalni ročaj ni medicinski proizvod, zato ni primeren za telesno prizadete osebe, temveč je namenjen le za privatno uporabo.
- ⚠ Za držanje se sme uporabljati izključno držalni ročaj, preostali proizvodi niso primerni za tovrstno uporabo.
- ⚠ V periodičnih presledkih (letno) je treba preverjati pravilno pritrditev in trdnost naseda montiranih proizvodov.

## Οδηγίες συναρμολόγησης

- Κατά τη συναρμολόγηση του προϊόντος από καταρτισμένο και εξειδικευμένο προσωπικό θα πρέπει να δοθεί προσοχή, ώστε η επιφάνεια στερέωσης στη συνολική περιοχή στερέωσης να είναι επίπεδη (να μην υπάρχουν προεξέχοντες αρμοί ή λιθογόμωση πλακιδίων), ώστε η κατασκευή του τοίχου να είναι κατάλληλη για τη συναρμολόγηση του προϊόντος και ώστε η επιφάνεια να μην παρουσιάζει αδύναμα σημεία. Οι συνημμένες βίδες και οι στυλίσκοι ενδείκνυνται μόνο για σκυρόδεμα. Σε άλλες επίτοιχες κατασκευές θα πρέπει να δοθεί προσοχή στα δεδομένα του Κατασκευαστή των στυλίσκων.
- Πριν τη συναρμολόγηση πρέπει να εξεταστεί το προϊόν για ζημιές μεταφοράς. Μετά την εγκατάσταση δεν αναγνωρίζονται ζημιές από τη μεταφορά ή επιφανειακές ζημιές.

## Περιγραφή συμβόλων



Μην χρησιμοποιείτε σιλικόνη που περιέχει οξικό οξύ!



**Διαστάσεις** (βλ. σελίδα 21)



**Ανταλλακτικά** (βλ. σελίδα 23)



**Καθαρισμός**

βλ. συνημμένο φυλλάδιο

## Navodila za montažo

- Kamorkoli bo pogodbjenik namestil izdelek, mora poskrbeti, da je celotno območje stene na katero bo plošča nameščena ravno (brez štrlečih fug ali robov ploščic), ter da je struktura stene primerna za namestitvev in je brez šibkih točk. Priloženi vijaki in ležaji so primerni le za beton. Za ostale zidne konstrukcije je potrebno upoštevati proizvajalčeva navodila.
- Pred montažo je treba izdelek preveriti glede morebitnih transportnih poškodb. Po vgradnji transportne ali površinske poškodbe ne bodo več priznane.

## Opis simbola



Ne smete uporabiti silikona, ki vsebuje očetno kislino!



**Mere** (glejte stran 21)



**Rezervni deli** (glejte stran 23)







**Čiščenje**

glejte priloženi brošuri.





## Ohutusjuhised

-  Kandke paigaldamisel muljumis- ja löikevigastuste vältimiseks kindaid.
-  Käepideme 42730000 sihipärane kasutamine: käepide ei ole meditsiinitoode, see ei sobi füüsilise puudega inimestele, vaid on mõeldud erakasutuseks.
-  Käepidet võib kasutada ainult kinnihoidmiseks, ülejäänud tooted ei sobi selleks kasutusotstarbeks.
-  Monteeritud toote nõuetekohast paigaldust ja kinnitust tuleb korrapäraselt (kord aastas) kontrollida.

## Paigaldamisjuhised

- Toote paigaldamisel peab töövõtja tagama, et kogu seinapind, kuhu paigaldusplaat kinnitatakse, on lame (ükski vuuk ega keraamiline plaat ei ulatu esile), ning et seina konstruktsioon on toote paigaldamiseks sobiv ja sellel puuduvad nõrgad kohad. Kaasasolevad kruvid ja tüüblid sobivad üksnes betoonile. Muude seinakonstruktsioonide puhul tuleb arvesse võtta tüüblitootja esitatud tooteandmeid.
- Enne paigaldamist tuleb toodet kontrollida transpordikahjustuste osas. Pärast paigaldamist ei tunnustata enam transpordi- või pinnakahjustuste kaebuseid.

## Sümbolite kirjeldus



Ärge kasutage äädikhapet sisaldavat silikooni!



**Mõõtude** (vt lk 21)







**Varuosad** (vt lk 23)



**Puhastamine**

vt kaasasolevast brošüürist.

## Drošības norādes

-  Montāžas laikā, lai izvairītos no saspiedumiem un iegriezumiem, nepieciešams nēsāt cimdus.
-  Roktura 42730000 pareiza lietošana: rokturis nav medicīniskais produkts, tas ir piemērots nevis personām ar īpašām fiziskām vajadzībām, bet gan tikai privātai lietošanai.
-  Turēšanai drīkst izmantot vienīgi rokturi, pārējie produkti nav piemēroti šim nolūkam.
-  Nepieciešams periodiski (reizi gadā) pārbaudīt, vai uzmontētie produkti ir pareizi piestiprināti un labi turas.

## Norādījumi montāžai

- Ja izstrādājuma montāžu veic kvalificēti speciālisti, jāseko, lai nostiprināšanas virsma visā nostiprināšanas zonā būtu gluda (šuves un flizes nav izvirzītas uz āru), lai sienas konstrukcija būtu piemērota izstrādājuma montāžai un būtu pietiekami izturīga. Komplektā esošās skrūves un dībeļi ir paredzēti tikai šī izstrādājuma nostiprināšanai. Ja sienas konstrukcija ir citāda, jāievēro dībeļu ražotāja norādījumi.
- Pirms montāžas nepieciešams pārbaudīt, vai produktam transportēšanas laikā nav radušies bojājumi. Pēc iebūvēšanas bojājumi, kas radušies transportēšanas laikā, vai virsmas bojājumi netiek atzīti.

## Simbolu nozīme



Neizmantot silikonu, kas satur etiķskābi!



**Izmērus** (skat. 21. lpp.)



**Rezerves daļas** (skat. 23. lpp.)



**Tīrīšana**

skatiet pievienotajā brošūrā.





**Paigaldamine**  
vt lk 17



**Montāža**  
skat. 17. lpp.



## Sigurnosne napomene

-  Prilikom montaže se radi sprečavanja prignječenja i posekotina moraju nositi rukavice.
-  Namenska upotreba drške 42730000: Drška nije medicinski proizvod i nije podesna za korišćenje od strane telesno hendikepiranih osoba, već je namenjena isključivo za upotrebu u privatnom okruženju.
-  Za držanje sme da se koristi isključivo drška, svi ostali proizvodi su za tu svrhu nepodesni.
-  Propisna pričvršćenost i stabilnost postavljenih proizvoda treba redovno da se proverava (jednom godišnje).

## Instrukcije za montažu

- Kada proizvod montira kvalifikovano stručno osoblje treba paziti da čitava površina na koju se učvršćuje bude ravna (bez istaknutih fuga ili krivljenja pločica), da je zidna konstrukcija primerena montaži proizvoda, i posebno da nema slabih mesta. Priloženi zavrtnji i tiplovi prikladni su samo za beton. Kod drugih zidnih nadgradnji treba obratiti pažnju na navode proizvođača tiplova.
- Pre montaže se mora proveriti da li je proizvod oštećen pri transportu. Nakon ugradnje se ne priznaju nikakve reklamacije koje se odnose na površinska i transportna oštećenja.

## Opis simbola



Nemojte koristiti silikon koji sadrži sircetnu kiselinu!



**Mere** (vidi stranu 21)







**Rezervni delovi** (vidi stranu 23)



**Čišćenje**

vidi priloženoj brošuri.

## Sikkerhetshenvisninger

-  Bruk hansker under montasjen for å unngå klem- og kuttskader.
-  Bestemmelsemessig bruk av håndtak 42730000: Håndtaket er ikke et medisinsk produkt som egner seg for personer med handicap. Det er kun bestemt for privat bruk.
-  For å holde seg fast skal kun håndtaket brukes. De øvrige produktene er ikke egnet for dette bruk.
-  De monterte produktene skal regelmessig sjekkes om de er ordentlig festet og om de sitter fast.

## Montagehenvisninger

- Når kvalifisert fagfolk monterer produktet, skal man påse at hele området der produktet monteres er plant (ingen fremstående fuger eller flisekanter), at oppbygging av veggene er egnet for montasje av produktet og at veggene ikke viser noen svakpunkter. Medleverte skruer og plugg er egnet seg kun for betong. Ved en annen veggoppbygging skal man ta hensyn til pluggprodusentens henvisninger.
- Før montasjen skal produktet sjekkes for transportskader. Etter monteringen aksepteres ikke noen transport- eller overflateskader.

## Symbolbeskrivelse



Ikke bruk silikon som inneholder eddiksyre!



**Mål** (se side 21)



**Service deler** (se side 23)







**Rengjøring**

se vedlagt brosjyre.





## Указания за безопасност

-  При монтажа трябва да се носят ръкавици, за да се избегнат наранявания поради притискане или порязване.
-  Използване по предназначение на дръжката 42730000: Дръжката не е медицински продукт, тя не е предназначена за използване от лица с физически недостатъци, а само в частната сфера.
-  За хващане да се използва само дръжката, останалите продукти не са подходящи за тази цел.
-  Правилното закрепване и правилното разположение на монтираните продукти трябва да се проверява периодично (ежегодно).



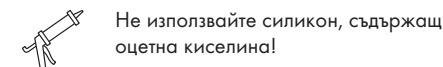

## Указания за монтаж

- При монтаж на продукта от квалифицирани специалисти да се внимава за това, закрепващата повърхност в целия диапазон на закрепването да бъде равна (без изпъкнали фуги или изместване на плочки), конструкцията на стената да е подходяща за монтаж на продукта и особено за това, да няма слаби места. Приложените винтове и дюбели са подходящи само за бетон. При други стенни конструкции да се спазват данните на производителя на дюбели.
- Преди монтажа продуктът трябва да се провери за транспортни щети. След монтажа не се признават транспортни или повърхностни щети.

## Описание на символите



## Udhëzime sigurie

-  Për të evituar lëndimet e pickimeve ose të prerjeve gjatë procesit të montimit duhet që të vishni doreza.
-  Përdorimi i rregullt i dorezës 42730000: Doreza nuk është produkt mjekësor. Ajo nuk është paraparë për persona me kufizime fizike por vetëm për sferën private.
-  Vetëm doreza mund të përdoret për t'u mbajtur. Të gjitha produktet e tjera nuk janë të përshtatshme për këtë qëllim.
-  Montimi dhe pozicioni sipas rregullave i produkteve të montuara duhet verifikuar periodikisht (një herë në vit).

## Udhëzime për montimin

- Gjatë montimit të produktit nga ana e personit të kualifikuar duhet pasur parasysht që e gjithë sipërfaqja mbërthyesë të jetë e drejtë (nuk duhet të ketë hapësira mes pllakave). Mbi të gjitha muri duhet të jetë i përshtatshëm për montim dhe nuk duhet të ketë pika të dobëta. Vidhat dhe kunjat e bashkangjitura janë të përshtatshme vetëm për beton. Te përbërja tjetër mureve të merren parasysht të dhënat e prodhuesit të kunjave.
- Përpara montimit duhet që produkti të kontrollohet për dëmtime nga transporti. Pas instalimit nuk do të njihet asnjë dëmtim nga transporti ose dëmtim i sipërfaqes.

## Përshkrimi i simbolit

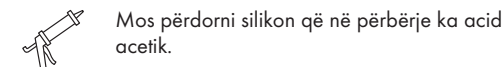



## تنبيهات الأمان



يجب إرتداء قفازات للبيد أثناء التركيب لتجنب حدوث أخطار الإنحشار أو الجروح.



الاستخدام المطابق للشروط للمقبض 42730000 لا يعتبر هذا المقبض منتجاً طبياً، كما أنه غير ملائم للأشخاص المصابين بإعاقة بدنية وإنما هو مخصص للاستخدام الشخصي فحسب.



يحظر استخدام المقبض إلا من أجل التثبيت فحسب. وبالنسبة لبقية المنتجات الأخرى، فهي غير صالحة لهذا الغرض من الاستخدام.



يتعين التأكد من أن حالة التثبيت مطابقة للشروط المحددة والتأكد من الوضع الثابت للمنتجات المركبة على فترات منتظمة سنوياً



## تعليمات التركيب

- يجب الانتباه عند تركيب المنتج بواسطة فريق العمل المتخصص إلى أن جميع مواضع التثبيت جاهزة للتثبيت دون عوائق (خالية من المفصلات أو الملتصقات)، وأن الحائط جاهز لتركيب المنتج مع عدم احتوائه على أية أماكن ضعيفة. مبيبات المسامير (الفيشر) والمسامير نفسها مناسبة للحوائط الخرسانية فقط، ويجب الالتزام بتعليمات الجهة المصنعة لمبيبات المسامير عند التثبيت في أنواع أخرى من الحوائط.
- قبل القيام بعملية التركيب، يجب فحص المنتج للتأكد من خلوه من أية تلفيات ناتجة عن النقل. بعد القيام بعملية التركيب، لن يتم الاعتراف بوجود أية تلفيات سطحية أو تلفيات ناتجة عن عملية النقل.

## وصف الرمز

هام! لا تستخدم السليكون الذي يحتوي على أحماض!



أبعاد (راجع صفحة 21)



قطع الغيار (راجع صفحة 23)



## التنظيف

راجع والكتيب المرفق



## التركيب

راجع صفحة 17





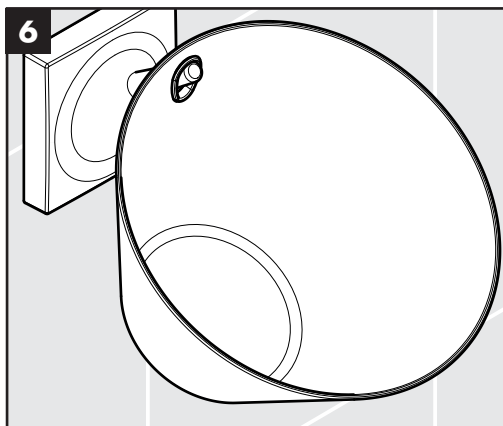
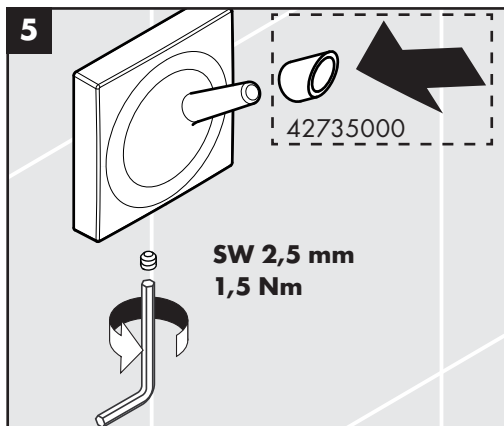
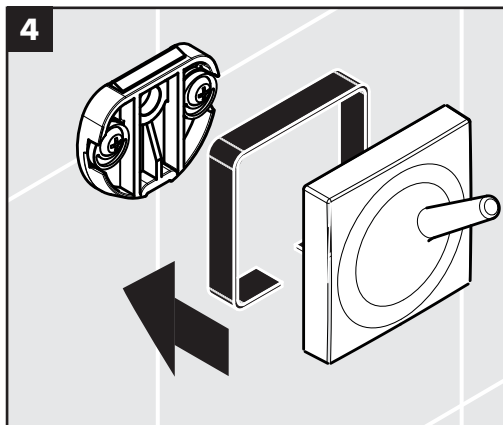
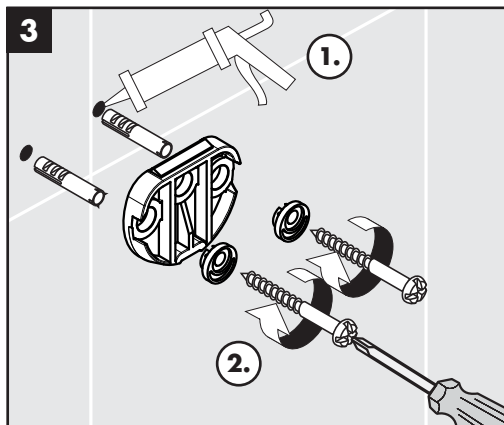
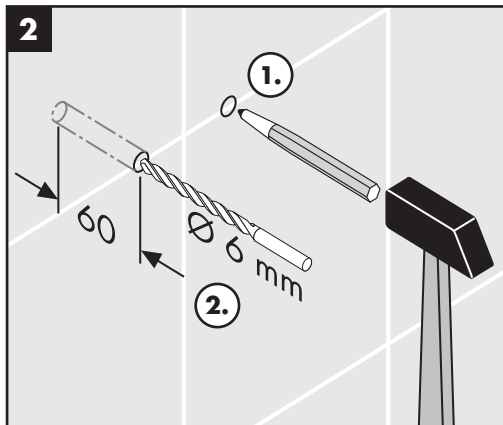
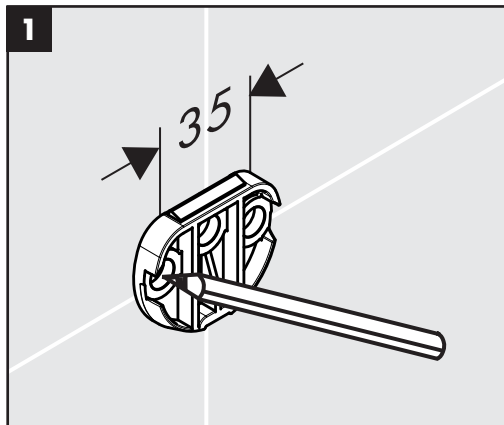



## Starck Organic 42736000

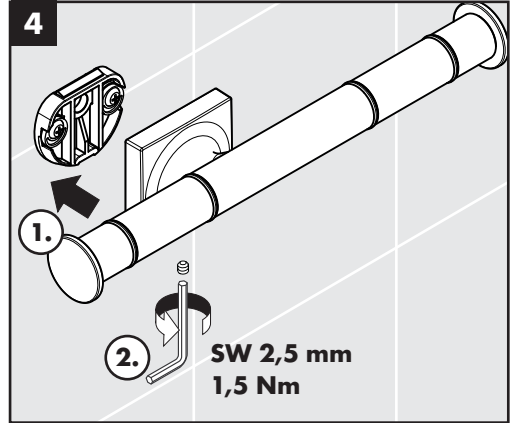
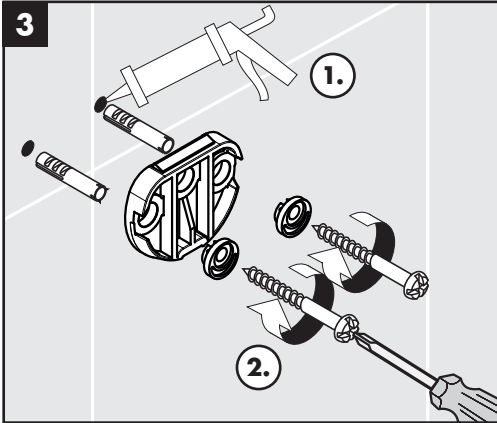
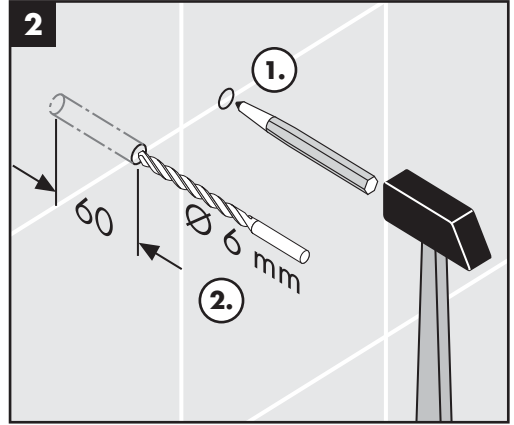
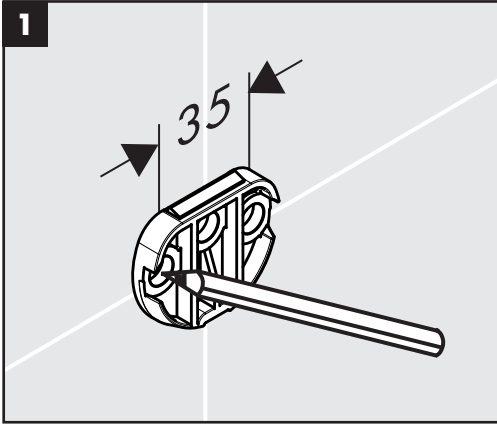

## Starck Organic 42706000 / 42708000

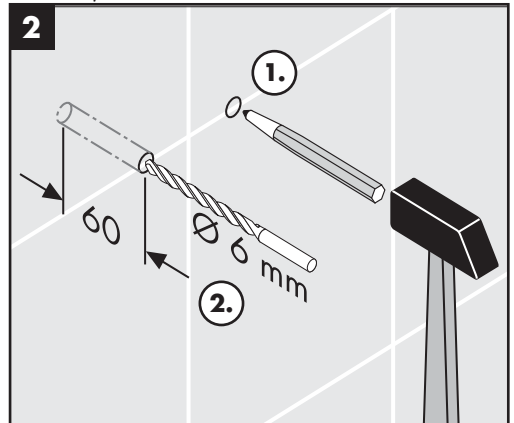
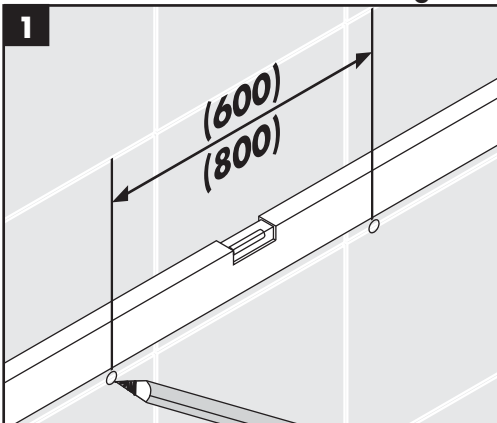

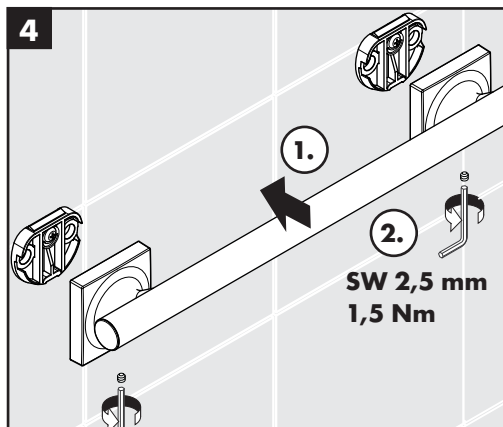
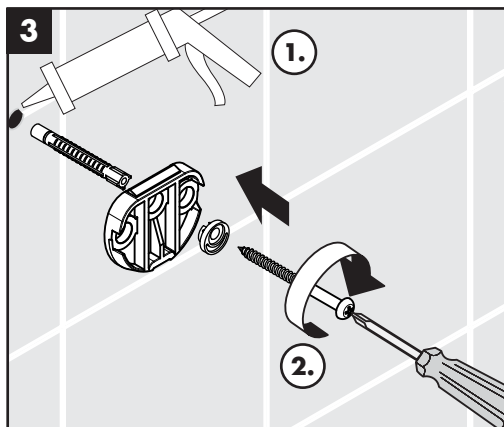

Starck Organic 42730000

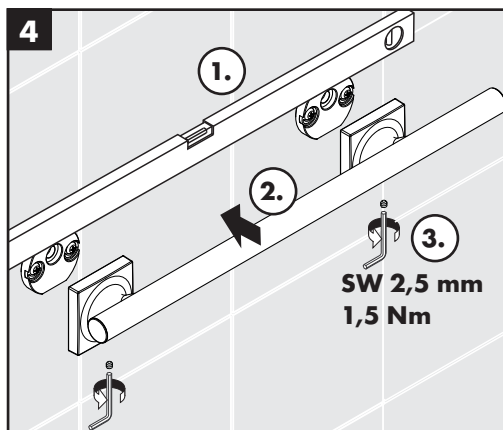
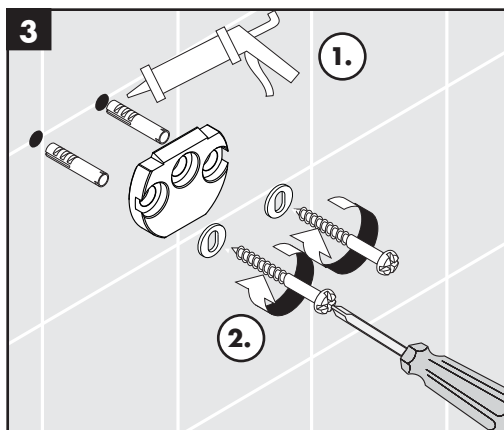
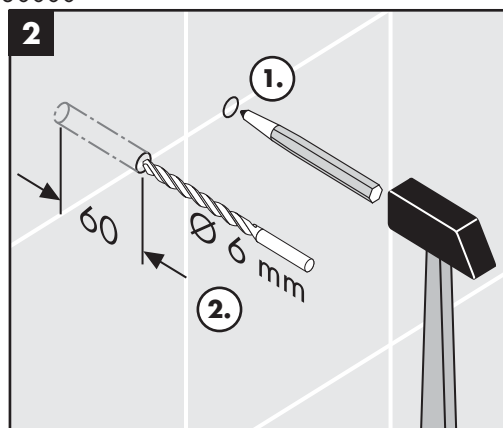
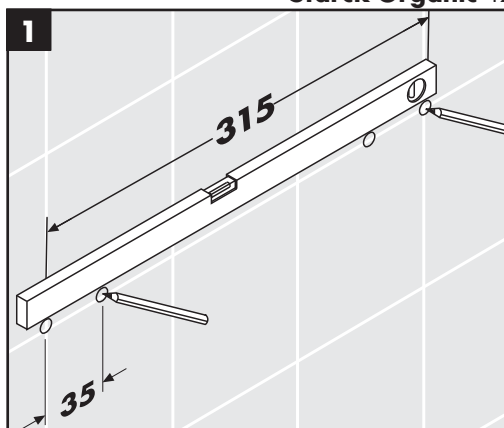



Starck Organic 42720000

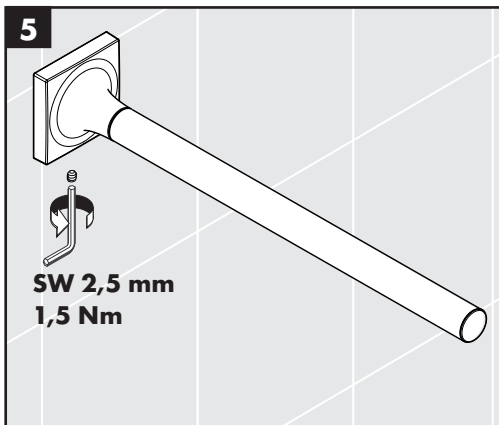
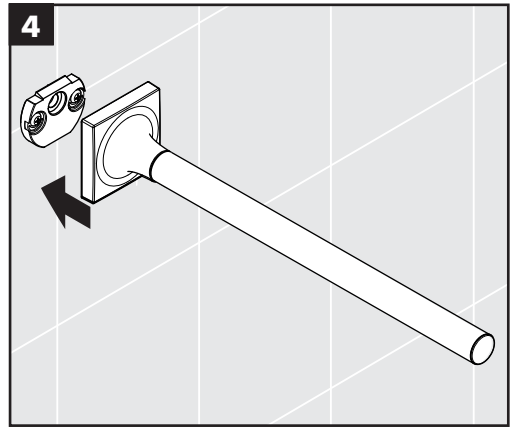
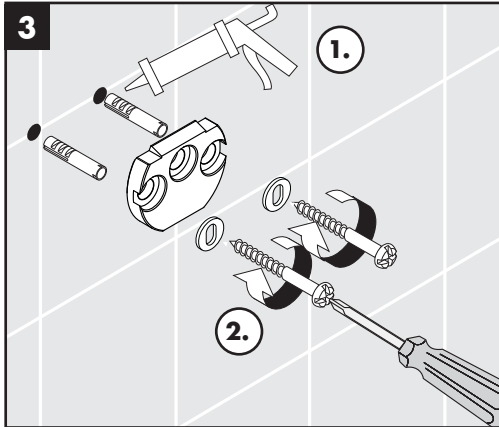
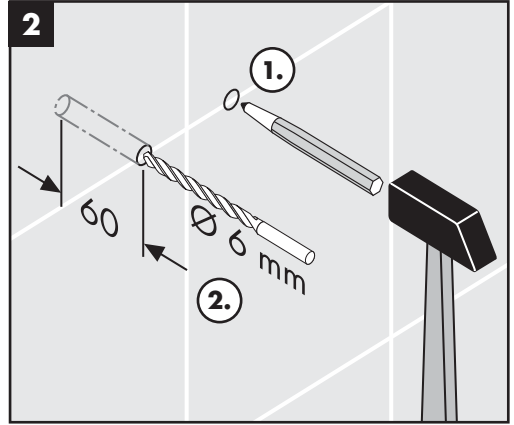
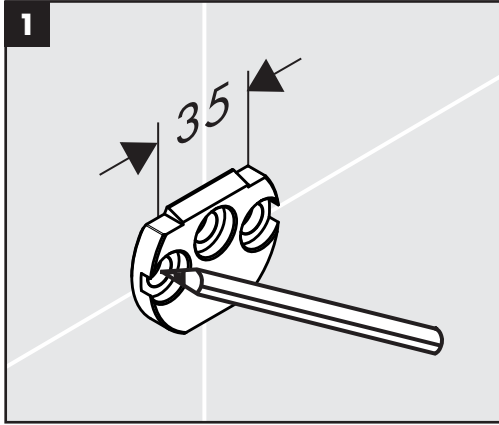

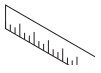

**Starck Organic**  
42737000

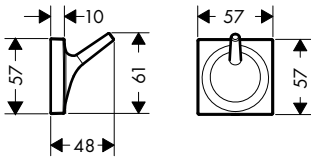

**Starck Organic**  
42733000

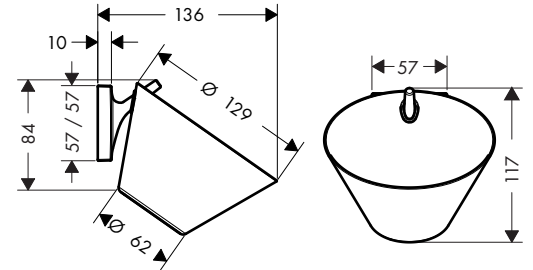

**Starck Organic**  
42730000

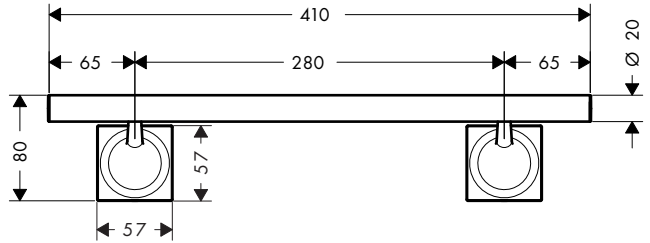
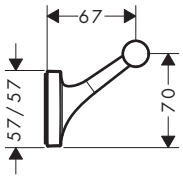

**Starck Organic**  
42706000

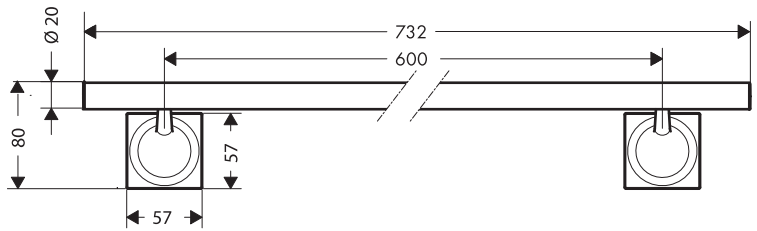
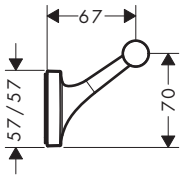

**Starck Organic**  
42708000

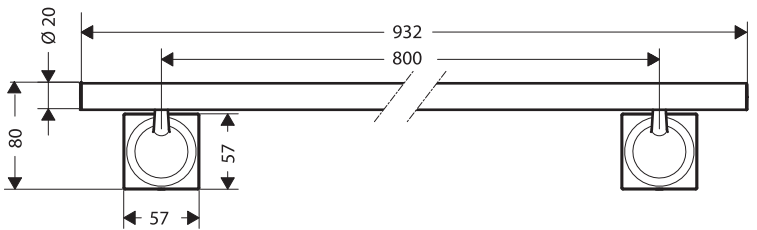
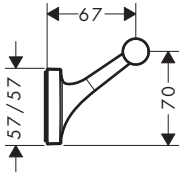

**Starck Organic**  
42736000

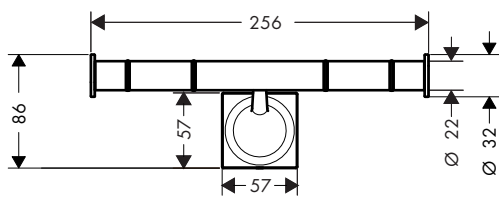
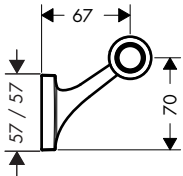



**Starck Organic**

42720000

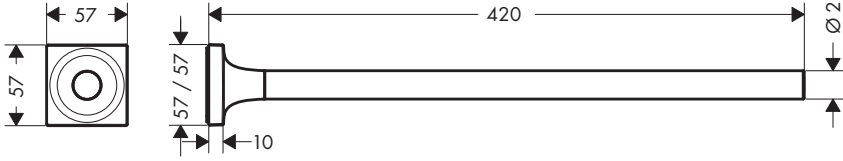

**Starck Organic**

42734000

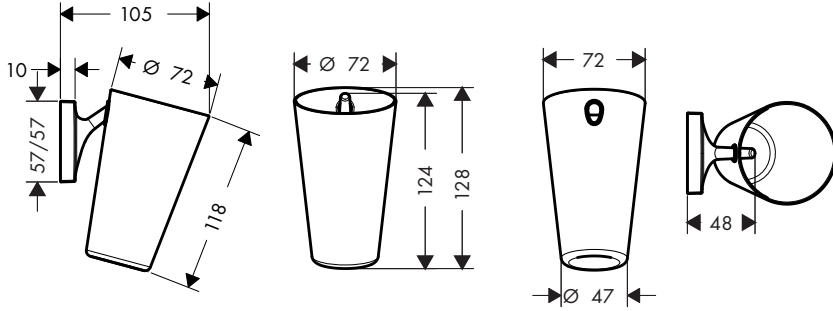

**Starck Organic**

42735000

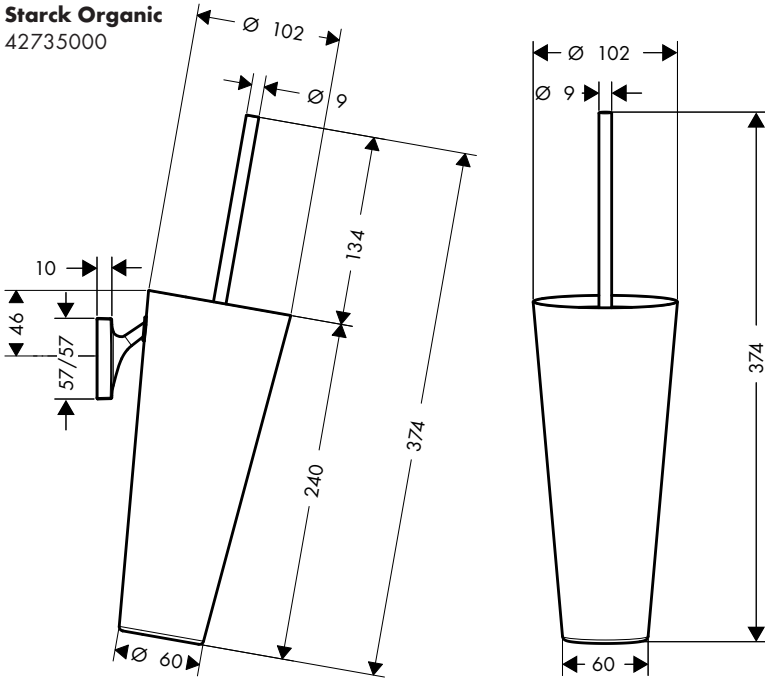



**Starck Organic**  
42730000

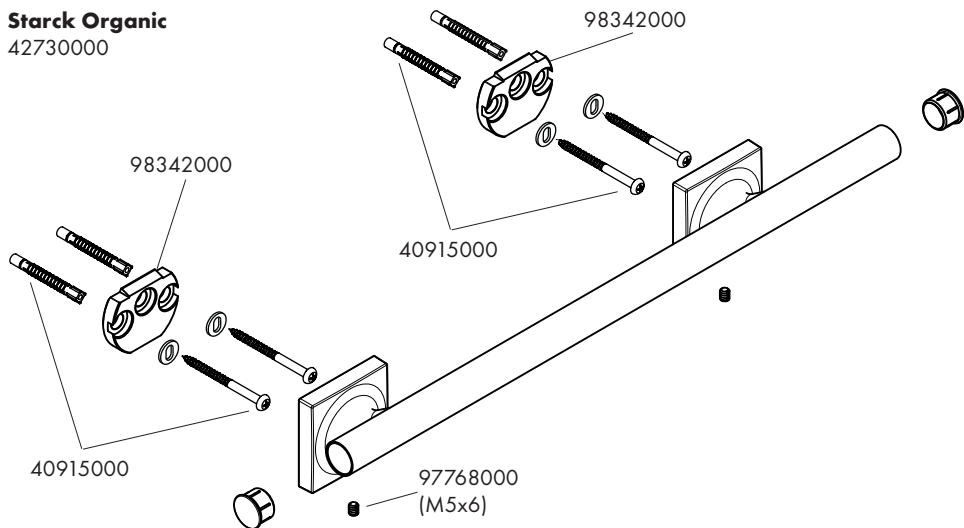

**Starck Organic**  
42706000 /  
42708000

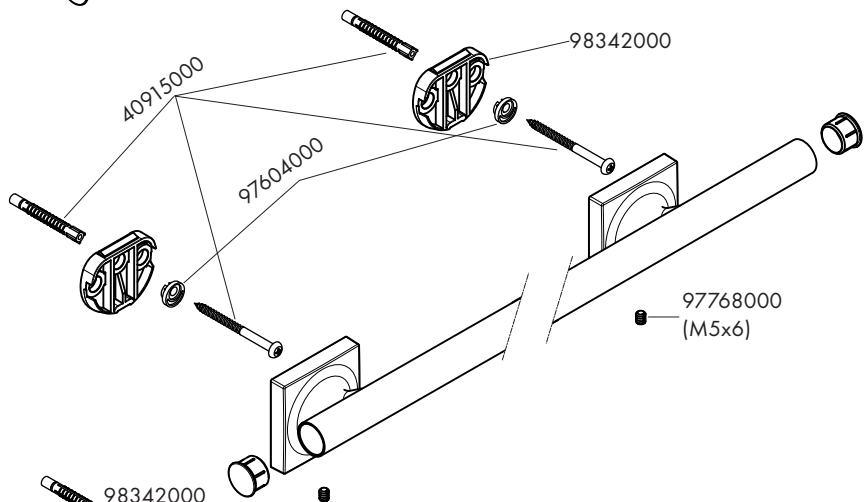

**Starck Organic**  
42736000

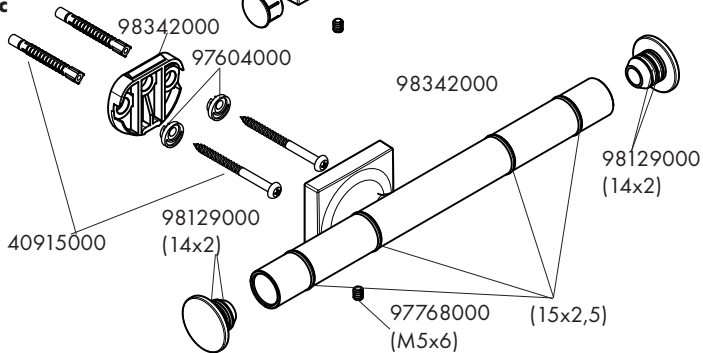



### Starck Organic

42737000

42733000 / 42734000

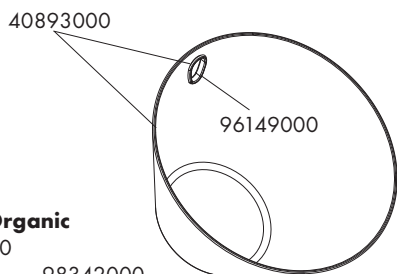
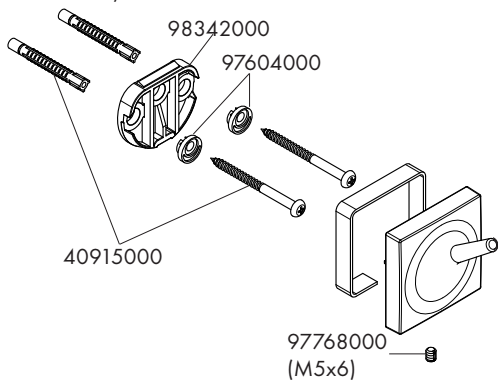

### Starck Organic

42720000

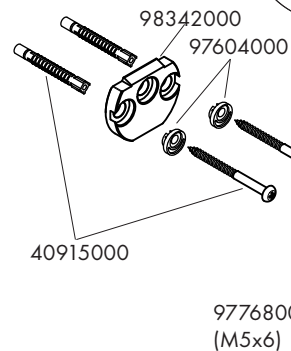

### Starck Organic

42735000

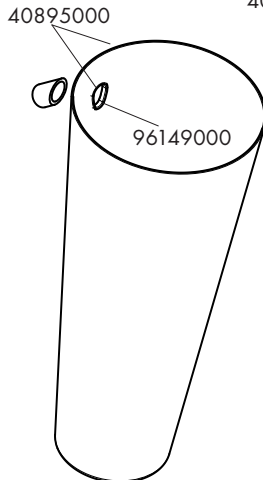
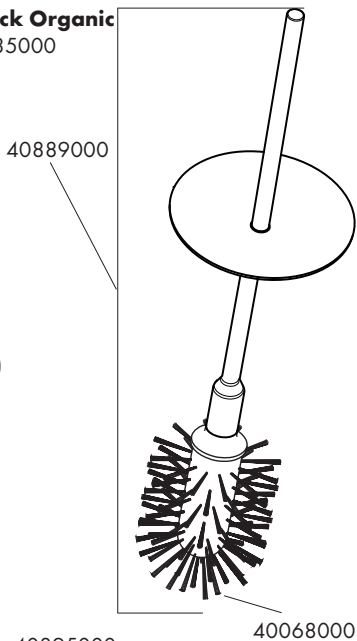
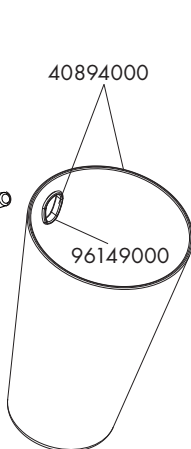

**hansgrohe**