

ASSEMBLY INSTRUCTIONS

ITEM# DC49020 | Crinkle Shade Clamp Lamp

ITEM DESCRIPTION

MATERIAL TYPE: Brass+Metal +fabric FINISH: ANTIQUE BRASS / WHITE LINEN TOP COAT/SEALANT

SOCKET TYPE: E12 CERAMIC SOCKET QTY: 1PC

BULB TYPE: TYPE B BULB WATTAGE: 40W or/CFL 9W or/LED 6W VOLTAGE: 110V-120V

ITEM NET WEIGHT:

UL COMPLIANT

INSTALLATION ENVIRONMENT: SUITABLE FOR DRY LOCATIONS

NOTE:

- *YOUR PRODUCT(S) MAY BE PACKED IN MORE THAN ONE CARTON
- *THIS ITEM MAY REQUIRE PERIODIC TIGHTENING
- *MIN 90°C SUPPLY CONDUCTORS



PARTS

A	ADJUSTING KNOB	1 PC
B	CLAMP	1 PC
C	SOCKET	1 PC
D	SHADE	1 PC
E	SOCKET RING	1 PC

PRODUCT ASSEMBLY

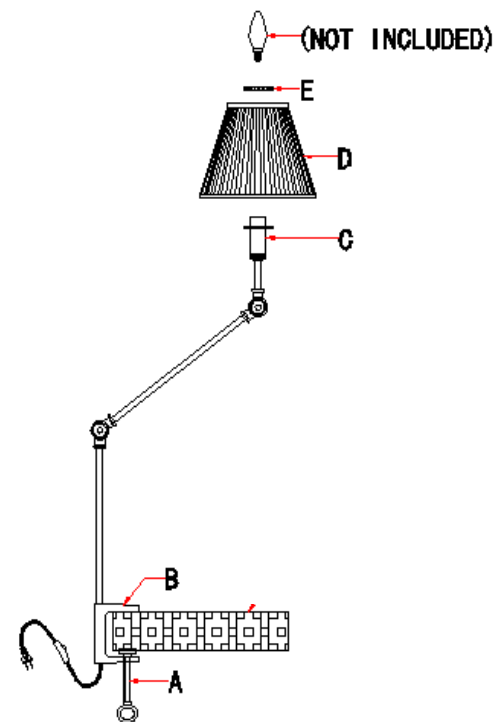

ASSEMBLY INSTRUCTIONS

1. REMOVE ALL PACKING CONTENTS AND PARTS FROM THE CARTON(S) CAREFULLY.
2. PLEASE BE SURE YOU HAVE ALL PARTS INDICATED BEFORE YOU BEGIN ASSEMBLY.
3. PLACE ALL PARTS OF THE LAMP ON A FLAT SURFACE.
4. REMOVE THE SOCKET RING (E) FROM THE SOCKET (C).
5. INSERT 1 TYPE B 40W BULB (OR/CFL 9W OR/LED 6W, NOT INCLUDED) INTO THE SOCKET (C). **DO NOT EXCEED THE SPECIFIED WATTAGE.**
6. ATTACH THE SHADE (D) ON THE SOCKET (C) AND FASTEN IT WITH THE SOCKET RING (E).
7. CLAMP THE LAMP ON THE DESIRED LOCATION OF THE DESK, AND SECURE IT WITH ADJUSTING KNOB (A) BY TURNING IN A CLOCKWISE DIRECTION TILL TIGHT.
8. LAMP AND SHADE ASSEMBLY IS COMPLETE
9. THIS LAMP COMES WITH A POLARIZED PLUG AS A FEATURE TO REDUCE RISK OF ELECTRICAL SHOCK.
IF PLUG DOES NOT FIT IN YOUR OUTLET CONTACT A LICENSED ELECTRICIAN NEVER ALTER PLUG
10. REMOVE PLUG FROM WALL OUTLET BEFORE REPLACING LIGHT BULB

CARE & MAINTENANCE

DUST WITH A DRY CLOTH.

FOR CUSTOMER SERVICE QUESTIONS CALL 1.888.488.8866

ARTERIOS HOME: 972.488.9800

ARTERIOS CONTRACT: 972.488.9800 EXT. 321

DISCLAIMERS

WE RECOMMEND THE INSTALLATION OF THIS ELECTRICAL LIGHT FIXTURE TO BE DONE BY A LICENSED ELECTRICIAN.

ARTERIOS