Sno-Tek™ By Ariens

Owner/Operator Manual Manuel Du Propriétaire/Utilisateur

Models

920402 – Sno-Tek 24E

(Serial No. 075000 and up)

920403 – Sno-Tek 28E

(Serial No. 075000 and up)

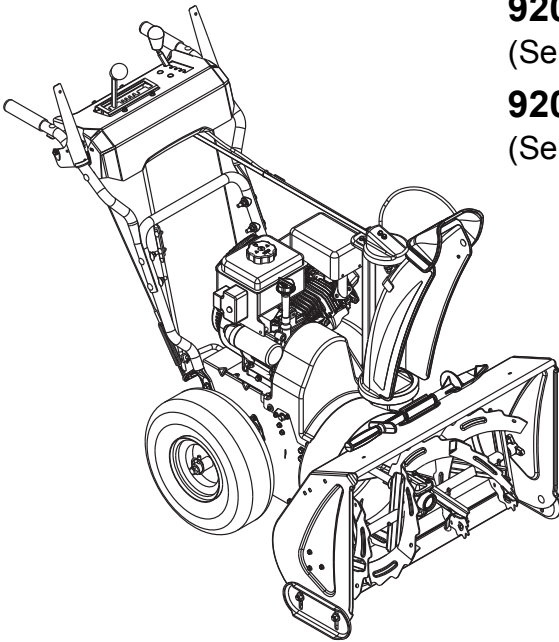

Gasoline containing up to 10% ethanol (E10) or up to 10% MTBE (methyl tertiary butyl ether) is acceptable for use in this machine. The use of any gasoline exceeding 10% ethanol (E10) or 10% MTBE will void the product warranty.

Il est possible d'utiliser de l'essence contenant jusqu'à 10% d'éthanol (E10) ou 10% de MTBE (éther méthyl-tertiobutylrique) sur cette machine. L'utilisation d'une essence contenant plus de 10% d'éthanol (E10) ou de 10% de MTBE annulent la garantie.



GB ENGLISH

F FRANÇAIS

04435600B 7/12
Printed in USA

TABLE OF CONTENTS

| | | | |
|------------------------------|----|----------------------|----|
| SAFETY..... | 4 | STORAGE..... | 31 |
| ASSEMBLY..... | 9 | SERVICE PARTS..... | 32 |
| CONTROLS and FEATURES..... | 14 | ACCESSORIES..... | 32 |
| OPERATION..... | 15 | TROUBLESHOOTING..... | 33 |
| MAINTENANCE..... | 21 | SPECIFICATIONS..... | 35 |
| SERVICE AND ADJUSTMENTS..... | 24 | WARRANTY..... | 36 |

INTRODUCTION

NON-ENGLISH MANUALS



Manuals in languages other than English may be obtained from your Dealer. Visit your dealer or www.ariens.com for a list of languages available for your equipment.



Manuals printed in languages other than English are also available as a free download on our website:

<http://www.ariens.com>

MANUALES EN IDIOMAS DIFERENTES DEL INGLES



Puede obtener manuales en idiomas diferentes del inglés en su distribuidor. Visite a su distribuidor o vaya a www.ariens.com para obtener una lista de idiomas disponibles para su equipo.



También puede imprimir manuales en idiomas diferentes del inglés descargándolos gratuitamente de nuestra página Web:

<http://www.ariens.com>

MANUELS NON ANGLAIS



Des manuels dans différentes langues sont disponibles chez votre revendeur. Rendez-vous chez votre revendeur ou allez sur le site www.ariens.com pour consulter la liste des langues disponibles pour votre équipement.



Les manuels imprimés dans des langues différentes de l'anglais sont également disponibles en téléchargement gratuit sur notre site Web :

<http://www.ariens.com>

MANUALS

Before operation of unit, carefully and completely read your manuals. If used improperly, this unit could be dangerous and cause personal injury or property damage. The contents will provide you with safety instructions for the safe use of your unit during normal operation and maintenance. All reference to left, right, front, or rear are given from operator standing in operation position and facing the direction of forward travel.

ENGINE MANUAL

The engine on this unit is covered by a separate manual specific to the engine. This manual is included in the literature package that shipped with the unit. Refer to this manual for engine service recommendations. If the engine manual is not available, contact the engine manufacturer for a replacement manual.

MODEL AND SERIAL NUMBERS

When ordering replacement parts or making service inquiries, know the Model and Serial numbers of your unit and engine.

Numbers are located on the product registration form in the unit literature package. They are printed on a serial number label, located on the frame of your unit (Figure 1).

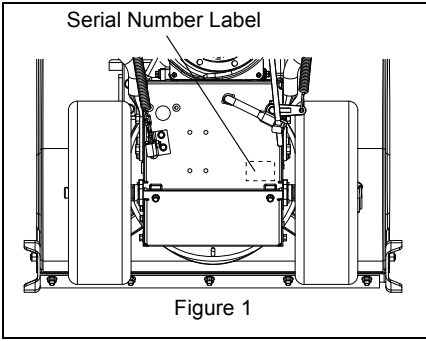

- Record unit model and serial numbers here.

- Record engine model and serial numbers here.

PRODUCT REGISTRATION

The Ariens dealer must register the product at the time of purchase. Registering the product will help the company process warranty claims or contact you with the latest service information. All claims meeting requirements during the limited warranty period will be honored, whether or not the product registration card is returned. Keep a proof of purchase if you do not register your unit.

Customer Note: If the dealer does not register your product, please fill out, sign, and return the product registration card to Ariens or go to www.ariens.com.

UNAUTHORIZED REPLACEMENT PARTS

Use only Ariens replacement parts. The replacement of any part on this vehicle with anything other than an Ariens authorized replacement part may adversely affect the performance, durability, or safety of this unit and may void the warranty. Ariens disclaims liability for any claims or damages, whether warranty, property damage, personal injury or death arising out of the use of unauthorized replacement parts. To locate your nearest Ariens dealer, go to www.ariens.com on the internet.

DISCLAIMER

Ariens reserves the right to discontinue, make changes to, and add improvements upon its products at any time without public notice or obligation. The descriptions and specifications contained in this manual were in effect at printing. Equipment described within this manual may be optional. Some illustrations may not be applicable to your unit.

DELIVERY

Customer Note: If you have purchased this product without complete assembly and instruction by your retailer, it is your responsibility to:

1. Read and understand all assembly instructions in this manual. If you do not understand or have difficulty following the instructions, contact your nearest Ariens dealer for assistance. Make sure all assembly has been properly completed.

NOTE: To locate your nearest Ariens dealer, go to www.ariens.com on the Internet.



WARNING: Improper assembly or adjustments can cause serious injury.

2. Understand all safety precautions provided in the manuals.
3. Review control functions and operation of the unit. Do not operate the unit unless all controls function as described in this manual.
4. Review recommended lubrication, maintenance and adjustments.
5. Review limited warranty policy.

NOTE: This machine comes with a three year limited warranty. The selling dealer is responsible for explaining the terms and limitations of the warranty coverage offered in the country of sale.

6. Fill out a product registration card and return the card to the Ariens Company or go to www.ariens.com.

SAFETY



WARNING: To avoid injury to hands and feet, always disengage clutches, shut off engine, and wait for all movement to stop before unclogging or working on snow thrower.

Hand contact with the rotating impeller is the most common cause of injury associated with snow throwers. Never use your hand to clean out the discharge chute.

Keep hands and feet away from auger and impeller.



WARNING: POTENTIALLY HAZARDOUS SITUATION! If not avoided, COULD RESULT in death or serious injury.



CAUTION: POTENTIALLY HAZARDOUS SITUATION! If not avoided, MAY RESULT in minor or moderate injury. It may also be used to alert against unsafe practices.

SAFETY ALERTS



Look for these symbols to point out important safety precautions. They mean:

Attention!



Personal Safety Is Involved!

Become Alert!

Obey The Message!

The safety alert symbols above and signal words below are used on decals and in this manual. Read and understand all safety messages.



DANGER: IMMINENTLY HAZARDOUS SITUATION! If not avoided, WILL RESULT in death or serious injury.

NOTATIONS

NOTE: General reference information for proper operation and maintenance practices.

IMPORTANT: Specific procedures or information required to prevent damage to unit or attachment.

PRACTICES AND LAWS

Practice usual and customary safe working precautions, for the benefit of yourself and others. Understand and follow all safety messages. Be alert to unsafe conditions and the possibility of minor, moderate, or serious injury or death. Learn applicable rules and laws in your area. Always follow the practices set forth in this manual.

REQUIRED OPERATOR TRAINING

Original purchaser of this unit was instructed by the seller on safe and proper operation. If unit is to be used by someone other than original purchaser; loaned, rented or sold, ALWAYS provide this manual and any needed safety training before operation.

SAFETY DECALS AND LOCATIONS

ALWAYS replace missing or damaged safety decals. Refer to figure below for safety decal locations.

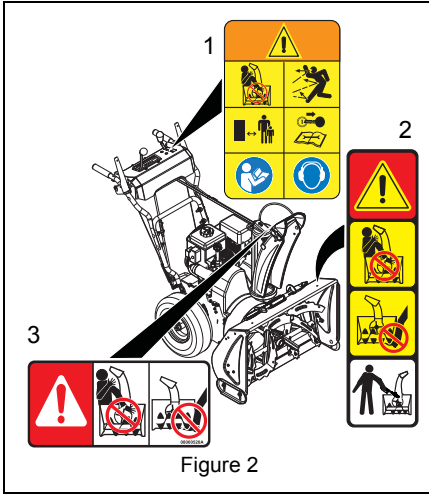

Figure 2

1. DANGER!



Danger!



ONLY use clean-out tool to clear blockages. NEVER use your hands.



Never direct discharge towards persons or property that may be injured or damaged by thrown objects.

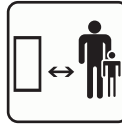

Keep people away from unit while operating. Keep children out of work area and under watchful care of a responsible adult.



Stop engine, remove key, read manual before making any repairs or adjustments.



Read Owner/Operator Manual.



Wear appropriate hearing protection.

2. DANGER!



Danger!



ROTATING PARTS! ONLY use clean-out tool to clear blockages. **NEVER** use your hands. **High speed impeller rotates below discharge opening. Wait for all moving parts to stop before removing clogs or servicing.**



EMISSION CONTROL SYSTEM

This equipment and/or its engine may include exhaust and evaporative emissions control system components required to meet U.S. Environmental Protection Agency (EPA) and/or California Air Resources Board (CARB) regulations. Tampering with emission controls and components by unauthorized personnel may result in severe fines or penalties. Emission controls and components can only be adjusted by an Ariens Company dealer or an authorized engine manufacturer's service center. Contact your Ariens Company Equipment Retailer concerning emission controls and component questions.

SAFETY RULES

Read, understand, and follow all safety practices in owner/operator manual before beginning assembly or operating. Failure to follow instructions could result in personal injury and/or damage to unit.

ALWAYS remove key and/or wire from spark plug before assembly, maintenance or service. Unintentional engine start up can cause death or serious injury.

Complete a walk around inspection of unit and work area to understand:

- Work area
- Your unit
- All safety decals

ALWAYS check overhead and side clearances carefully before operation. **ALWAYS** be aware of traffic when operating along streets or curbs.

Keep children and people away. Keep children out of work area and under watchful care of a responsible adult.

NEVER allow children to operate or play on or near unit. Be alert and shut off unit if children enter area.

DO NOT allow adults to operate unit without proper training. Only trained adults may operate unit. Training includes actual operation.

Keep area of operation clear of all toys, pets, and debris. Thrown objects can cause injury.

Check for weak spots on docks, ramps or floors. Avoid uneven work areas and rough terrain. Stay alert for hidden hazards.

DO NOT operate near drop-offs, ditches, or embankments. Unit can suddenly turn over if a wheel is over the edge of a cliff or ditch, or if an edge caves in.

Falling snow, fog, etc. can reduce vision and cause an accident. Operate unit only when there is good visibility and light.

NEVER operate unit after or during the use of medication, drugs or alcohol. Safe operation requires your complete and unimpaired attention at all times.

NEVER allow anyone to operate this unit when their alertness or coordination is impaired.

3. DANGER!



Danger!



ROTATING PARTS. Keep clear of auger while engine is running.

- Read Operator's Manual.
- Allow operation only by properly trained adult, never children.
- Stop engine and remove ignition key prior to leaving the operator's position for any reason.
- Keep all controls, guards and safety devices properly serviced and functional.
- Never direct discharge towards persons or property that may be injured or damaged by thrown objects.



DO NOT operate unit without wearing adequate winter outer garments. Wear adequate safety gear, including safety glasses with side shields, and protective gloves. Wear proper footwear to improve footing on slippery surfaces.

DO NOT wear loose clothing or jewelry and tie back hair that may get caught in rotating parts.

Protect eyes, face and head from objects that may be thrown from unit. Wear appropriate hearing protection.

Avoid sharp edges. Sharp edges can cut. Moving parts can cut off fingers or a hand.

ALWAYS keep hands and feet away from all rotating parts during operation. Rotating parts can cut off body parts.

NEVER place your hands or any part of your body or clothing inside or near any moving part while unit is running.

ALWAYS keep hands away from all pinch points.

DO NOT touch unit parts which might be hot from operation. Allow parts to cool before attempting to maintain, adjust or service.

Never direct discharge towards persons or property that may be injured or damaged by thrown objects. Use extreme caution on gravel surfaces. Stay alert for hidden hazards or traffic. Adjust skid shoes so scraper blade does not contact gravel.

DO NOT throw snow any higher than necessary.

Deflected materials can cause injury and property damage.

Always stand clear of the discharge area when operating this unit.

Fumes from engine exhaust can cause injury or death. DO NOT run engine in an enclosed area. Always provide good ventilation.

ALWAYS disengage attachment, stop unit and engine, remove key and allow moving parts to stop before leaving operator's position.

ROTATING IMPELLER CAN CAUSE SERIOUS INJURY. NEVER ATTEMPT TO UNCLOG OR CLEAN UNIT WHILE ENGINE IS RUNNING.

Read, understand, and follow all instructions in the manual and on the machine before starting.

Understand:

- How to operate all controls.
- The functions of all controls.
- How to STOP in an emergency.

Before starting engine, disengage control(s).

Use only approved extension cords and receptacles when starting units equipped with electric starter. DO NOT connect electric starter cord to any wiring system that is not a three wire grounded system.

ALWAYS allow unit and engine to adjust to outdoor temperatures before clearing snow.

Always be sure of your footing, especially when operating in reverse or leaving the operator's position. Walk, never run during operation.

DO NOT overload the machine capacity by attempting to operate or to clear snow at too fast a rate.

Slow down and turn corners slowly.

Do not operate in reverse unless absolutely necessary. ALWAYS back up slowly. Always look down and behind before and while backing.

Disengage attachment drive when traveling from one work area to another.

Abnormal vibrations are a warning of trouble. Striking a foreign object can damage unit. Immediately stop unit and engine. Remove key and wait for all moving parts to stop. Remove wire from spark plug. Inspect unit and make any necessary repairs before restart.

Before cleaning, removing clogs or making any inspections, repairs, etc.: disengage clutch(es), stop unit and engine, remove key, allow moving parts to stop. Allow hot parts to cool.

Run unit a few minutes after clearing snow to prevent freeze-up of attachment.

Disengage attachment when not in use.

Disengage all clutches before starting engine. Adjust skid shoes to clear gravel or crushed rock surfaces safely.

Never leave a running unit unattended.

ALWAYS shut off engine before leaving unit. ALWAYS remove key to prevent unauthorized use.

Never carry passengers.

Check clutch and brake operation frequently. Adjust and service as required. All motion of drive wheels and auger/impeller must stop quickly when control levers are released.

DO NOT operate on steep slopes. DO NOT clear snow across the face of slopes. Keep all movement on slopes slow and gradual. DO NOT make sudden changes in speed or direction. Use a slow speed to avoid stops or shifts on slopes. Avoid starting or stopping on a slope.

DO NOT park unit on a slope unless absolutely necessary. When parking on a slope always block the wheels.

ALWAYS shut off engine, remove key, and close fuel shut-off valve or drain fuel when transporting unit on a truck or trailer.

Use extra care when loading or unloading unit onto trailer or truck.

Secure unit chassis to transport vehicle. NEVER secure from rods or linkages that could be damaged.

DO NOT transport machine while engine is running.

Keep unit free of ice or other debris. Clean up oil or fuel spills.

This product is equipped with an internal combustion type engine. DO NOT use unit on or near any unimproved, forest-covered or brush covered land unless exhaust system is equipped with a spark arrester meeting applicable local, state or federal laws. A spark arrester, if it is used, must be maintained in effective working order by operator.

Fuel is highly flammable and its vapors are explosive. Handle with care. Use only an approved gasoline container with an appropriately sized dispensing spout.

NO smoking, NO sparks, NO flames. ALWAYS allow engine to cool before servicing.

NEVER fill fuel tank when engine is running or hot from operation.

NEVER fill or drain fuel tank indoors.

Replace fuel cap securely and clean up spilled fuel.

Never fill containers inside a vehicle or on a truck or trailer bed with a plastic liner. Always place containers on the ground away from your vehicle before filling.

When practical, remove gas-powered equipment from the truck or trailer and refuel it on the ground. If this is not possible, then refuel such equipment on a trailer with a portable container, rather than from a gasoline dispenser nozzle.

Keep the nozzle in contact with the rim of the fuel tank or container opening at all times until fueling is complete. Do not use a nozzle lock-open device.

If fuel is spilled on clothing, change clothing immediately.

Properly remove fuel before tipping unit up onto housing, so no spills will occur.

Secure unit so it will not tip over during maintenance.

ALWAYS keep protective structures, guards, and panels in good repair, in place and securely fastened. NEVER modify or remove safety devices.

DO NOT change engine governor settings or over-speed engine.

Fumes from engine exhaust can cause injury or death. DO NOT run engine in an enclosed area. Always provide good ventilation.

ALWAYS maintain unit in safe operating condition. Damaged or worn out muffler can cause fire or explosion.

Keep all hardware properly tightened. Check shear bolts frequently.

Maintain or replace safety and instruction labels, as necessary.

NEVER store unit with fuel in fuel tank, inside a building where any ignition sources are present such as hot water heaters, space heaters, or clothes dryers. Allow the engine to cool before storing in any enclosure.

Shut off fuel and allow engine to cool completely before storing in closed area or covering unit.

For extended storage, clean unit thoroughly. See engine manual for proper storage.

Use only attachments or accessories designed for your unit.

Check components frequently. If worn or damaged, replace with manufacturer's recommended parts.

ASSEMBLY



WARNING: AVOID INJURY. Read and understand the entire *Safety* section before proceeding.



WARNING: Dropping or tipping over boxed unit could result in personal injury or damage to unit.

PACKAGE CONTENTS

PACKAGE CONTENTS

Check the contents of your package for the parts listed below (Figure 3):

| Item | Part No. | Qty | Description |
|------|----------|-----|---------------|
| 1. | N/A | 1 | Sno-Tek™ Unit |

The following parts are included as a part of the Lower Handlebar:

| | | | |
|----|----------|---|---|
| 2. | 06221600 | 4 | 5/16 in x 2-1/4 in. Round Head Square Neck Grade 5 Bolt |
| 3. | 00597451 | 1 | Lower Handlebar |
| 4. | 07500005 | 4 | Handlebar Spacer |
| 5. | 06435700 | 4 | Flat Steel Washer |
| 6. | 06307400 | 4 | Locking Washer |
| 7. | 06530200 | 4 | 5/16 in Nyloc Nut |

| | | | |
|-----|----------|---|--|
| 8. | N/A | 1 | Upper Handlebar Assembly |
| 9. | N/A | 1 | Discharge Chute Assembly |
| 10. | N/A | 1 | Chute Crank Assembly |
| 11. | N/A | 1 | Literature Pack |
| 12. | 07028500 | 2 | 3/8 in x 3/4 in. Hex Head Serrated Flange Grade 5 Bolt |

If any of the contents listed are missing contact your local Ariens dealer. Use only Ariens approved parts; unapproved parts may void the unit warranty.

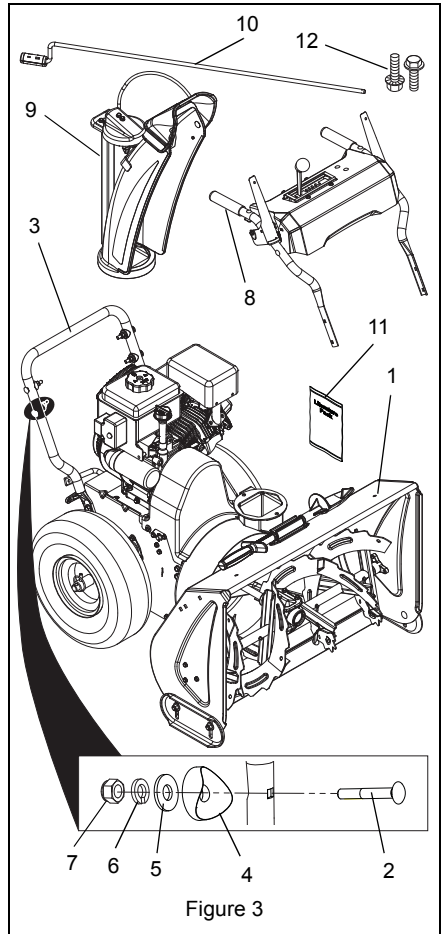

Figure 3

ASSEMBLY

Tools Required:

- Pliers
- Open-End Wrenches: 3/8, 7/16, 1/2, 9/16 in. and/or Adjustable Wrench
- Tire Gauge
- Torque Wrench (Optional)

Unfold Lower Handlebar

(Figure 4)

1. Remove wheel pins from each side of the unit and slide wheels away from frame (Figure 4). Do not remove wheels completely.

IMPORTANT: Be sure to block wheels or secure unit so it does not move during assembly.

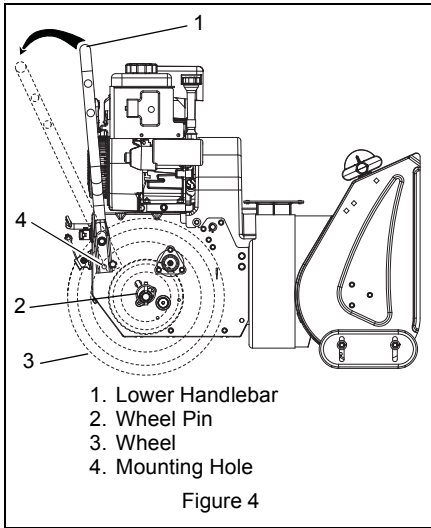

2. Rotate lower handlebar out from unit so lower handlebar mounting holes align with mounting holes on the unit frame.
3. Secure lower handlebar to unit using two 3/8 in x 3/4 in. hex head serrated flange grade 5 bolts (Figure 3, Item 12).
4. Tighten all four bolts to 25 – 42 lbf-ft (33.9 – 56.9 N•m).
5. Slide both wheels back into place and reinstall wheel pins (Figure 15).

Attach Upper Handlebar Assembly

(Figures 5 and 6)

1. Attach upper handlebar assembly to lower handlebar using two sets of the handlebar hardware. One set to attach each side of the handlebars (Figure 5).

IMPORTANT: DO NOT tighten hardware. Allow upper handlebar assembly to hang from the lower handlebars for the next step (Figure 5).

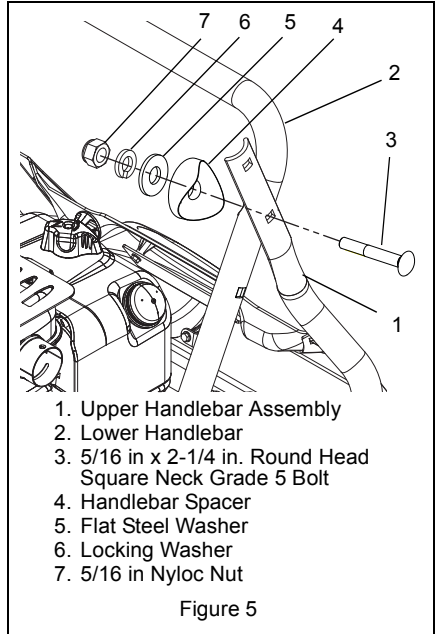

2. Hook spring end of attachment control cable to the clutch arm (Figure 6).
3. Hook spring end of the traction control cable to the cable eyelet on back of frame (Figure 6).

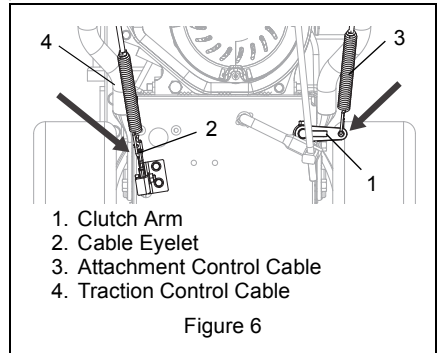

Unfold Upper Handlebar Assembly

(Figure 7)

1. Rotate the handlebar into operating position.

NOTE: Be careful not to damage cable spring hooks when rotating handlebar upward.

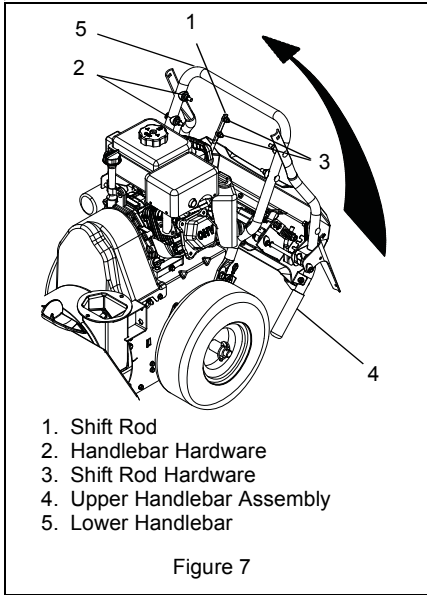

2. Install the remaining handlebar hardware attaching the upper handlebar assembly to the lower handlebar (Figure 5).
3. Tighten all hardware.
4. Remove packaging around shift rod.
5. Rotate shift rod into place and tighten hardware.
6. Connect shift rod to speed selector arm and adjust as specified in *Speed Selector Adjustment* on page 25.
7. Adjust attachment control cable as specified in *Attachment Clutch/Brake Adjustment* on page 26.
8. Adjust traction control cable as specified in *Traction Drive Clutch Adjustment* on page 28

Install Discharge Chute and Discharge Chute Crank

(Figures 8 and 9)

1. Remove mounting hardware from the auger housing.
2. Install discharge chute over opening in the auger housing. Finger tighten the mounting hardware removed in step 1.

NOTE: Leave discharge chute pedestal loose to help install the chute crank.

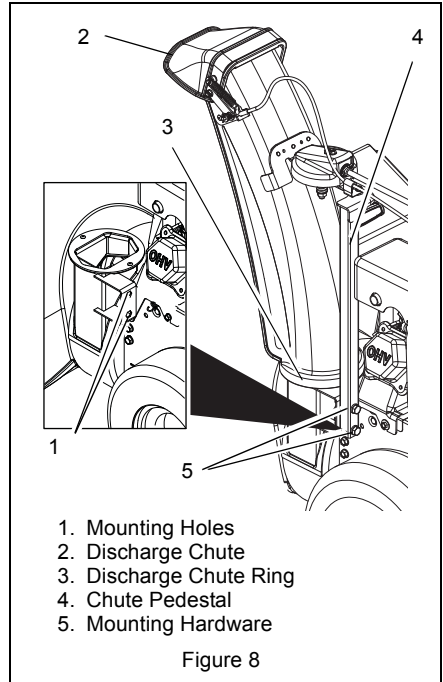

3. Slide chute crank through the nylon bushing in the support bracket under control panel.

NOTE: Be careful not to damage nylon bushing when attaching crank to the control panel.

4. Connect the chute crank to the pinion gear on discharge chute with spring clip pin.
5. Orient the chute and pedestal to its most vertical position and tighten pedestal hardware to 15 – 31 lbf-ft (20 – 42 N•m).

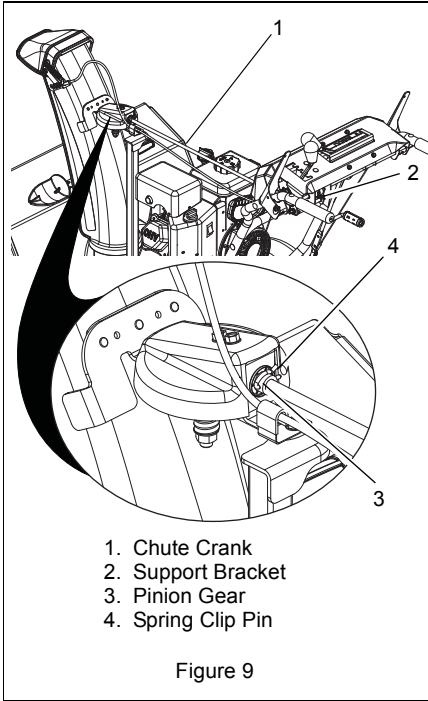

1. Chute Crank
2. Support Bracket
3. Pinion Gear
4. Spring Clip Pin

Figure 9

Install Remote Deflector Cable

(Figures 10 and 11)

1. Pull rubber seal cap away from snap fitting (Figure 10).

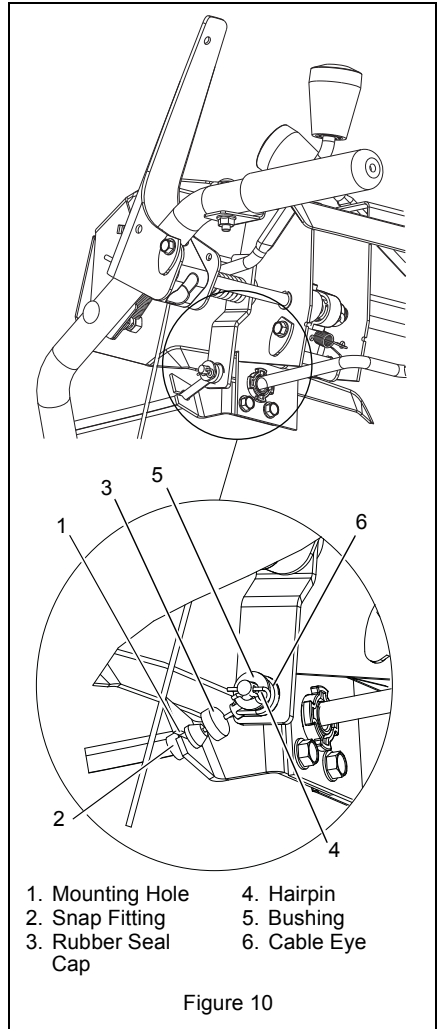

1. Mounting Hole
2. Snap Fitting
3. Rubber Seal Cap
4. Hairpin
5. Bushing
6. Cable Eye Cap

Figure 10

2. Install snap fitting into cable bracket's mounting hole located under the control panel.
3. Position rubber seal cap over the top of snap fitting.
4. Move deflector control lever to rear most position.
5. Attach cable eye to pin on bottom of deflector control lever.

NOTE: Hold down chute deflector cap, if needed, for more cable slack.

6. Secure cable eye to control lever with bushing and hairpin.
7. Using the wire hook attached to the deflector cable, hook cable to discharge chute crank (Figure 11).
8. Slide cable through clip on top of discharge chute pedestal (Figure 11).
9. Make sure deflector cable loops above gear cover between cable clip and cable support bracket (Figure 11).

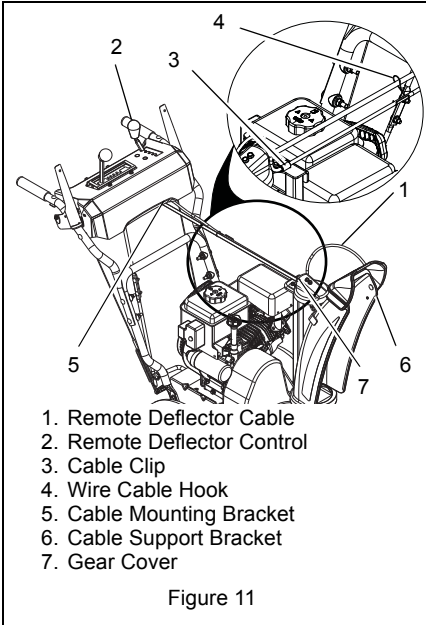

1. Remote Deflector Cable
2. Remote Deflector Control
3. Cable Clip
4. Wire Cable Hook
5. Cable Mounting Bracket
6. Cable Support Bracket
7. Gear Cover

Figure 11

10. Bend clip closed around cable.
11. Test controls to be sure deflector works properly.

NOTE: If deflector does not follow full range of travel See *Remote Discharge Deflector Control Adjustment* on page 24.

Check Function of Dual Handle Interlock

Without the engine running, press down (engage) both clutch levers. Release attachment clutch lever. Attachment clutch should remain engaged until traction drive clutch lever is released, then both clutches *must* disengage. If they do not, contact your dealer for repairs.

Check Tire Pressure

Check tire pressure and adjust to the pressure listed on tire sidewall.



CAUTION: Avoid injury! Explosive separation of tire and rim parts is possible when they are serviced incorrectly:

- Do not attempt to mount a tire without the proper equipment and experience to perform the job.
- Do not inflate the tires above the recommended pressure.
- Do not weld or heat a wheel and tire assembly. Heat can cause an increase in air pressure resulting in an explosion. Welding can structurally weaken or deform the wheel.
- Do not stand in front or over the tire assembly when inflating. Use a clip-on chuck and extension hose long enough to allow you to stand to one side.

Check Auger Gearcase Oil

Check oil level in auger gearcase (see *Check Auger Gearcase* on page 22).

Check Engine Crankcase Oil

IMPORTANT: The engine may be shipped with oil in crankcase. Refer to engine manual for detailed instructions.

Fill Engine Fuel Tank

Fill fuel tank. **DO NOT OVERFILL!** See *Filling Fuel Tank* on page 18.

Check Function of all Controls

Ensure unit runs and performs properly. Refer to *OPERATION* on page 15.

Run-in Attachment Belt

1. Start unit in a well-ventilated area according to *Starting and Shut Off* on page 19.
2. Engage attachment clutch lever and run attachment for about 15 minutes.
3. Stop unit, wait for all moving parts to stop, and remove spark plug wire.
4. Adjust clutch idler according to *Attachment Clutch/Brake Adjustment* on page 26.
5. Adjust belt finger, if necessary. See *Check Belt Finger Clearance* on page 27.

CONTROLS AND FEATURES

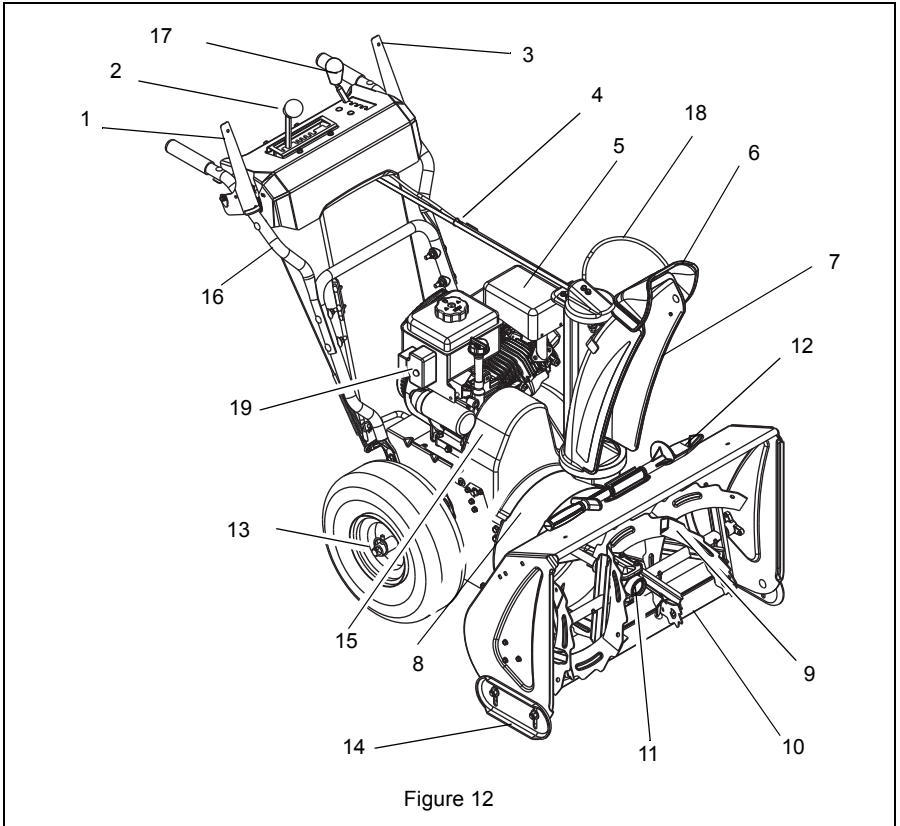

Figure 12

- | | |
|-------------------------------------|----------------------------------|
| 1. Attachment Clutch Lever | 12. Clean-out Tool |
| 2. Speed Selector | 13. Axle Lock Pin |
| 3. Traction Drive Clutch Lever | 14. Skid Shoe(s) |
| 4. Discharge Chute Crank | 15. Belt Cover |
| 5. Muffler Guard | 16. Handlebar |
| 6. Remote Discharge Chute Deflector | 17. Remote Deflector Control |
| 7. Discharge Chute | 18. Remote Chute Deflector Cable |
| 8. Impeller | 19. Electric Starter |
| 9. Auger | |
| 10. Scraper Blade | |
| 11. Auger Gearcase | |

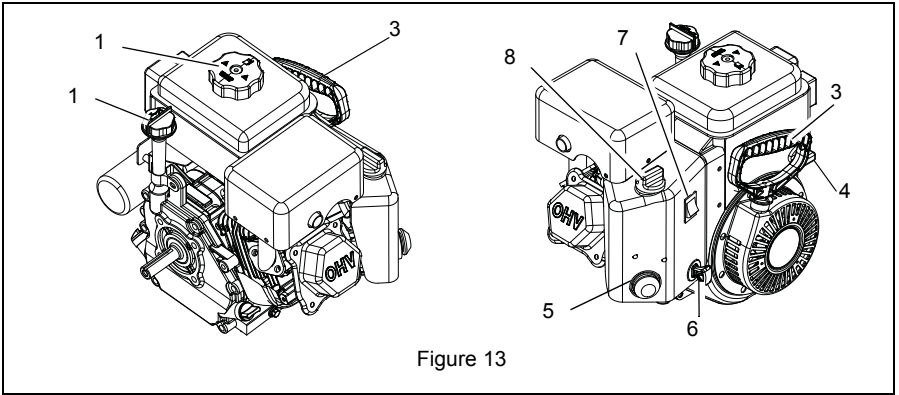

Figure 13

- | | |
|--------------------------|---------------------------------|
| 1. Oil Fill and Dipstick | 5. Primer Bulb |
| 2. Gas Tank and Cap | 6. Ignition Switch (Push /Pull) |
| 3. Recoil Starter Handle | 7. Engine Shutoff Switch |
| 4. Fuel Shut-off Valve | 8. Choke |

OPERATION

WARNING: AVOID INJURY. Read and understand the entire *Safety* section before proceeding.

WARNING: To avoid injury to hands and feet, always disengage clutches, shut off engine, and wait for all movement to stop before unclogging or working on snow thrower. Keep hands and feet away from auger and impeller.

CONTROLS AND FEATURES

See Figures 13 for Controls and Features locations.

Dual Handle Interlock

When attachment clutch and then traction drive clutch are engaged, the attachment clutch will remain engaged (lever down) if released. To stop attachment, release traction drive clutch and both clutches will disengage.

Traction Drive Clutch – Left Hand Lever

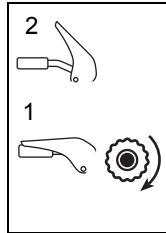

Squeeze the traction drive clutch lever against the handlebar (1) to engage wheel drive for propelling unit. Forward speed will vary according to snow depth and moisture content. Release lever (2) to stop movement.

NOTE: When traveling to or from the area to be cleared, press down on the handlebars enough to raise the front of the unit slightly off the surface. Engage the traction drive clutch without engaging the attachment clutch.

Attachment Clutch – Right Hand Lever

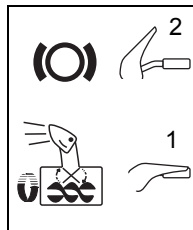

Squeeze attachment clutch lever against handlebar (1) to engage attachment. Release both clutch levers (2) to disengage power and apply brake to attachment.

IMPORTANT: If the belt squeals continuously when the attachment clutch lever is engaged, the impeller may be frozen in the auger housing. Immediately release the attachment clutch lever and move the unit into a heated area to thaw.

NOTE: If belt squeals continuously when impeller turns freely, see *Attachment Clutch/Brake Adjustment* on page 26.

Ignition Switch (Push/Pull Safety Key)

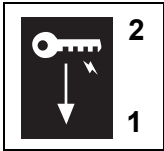

Key Switch has two positions:

1. "Stop" – pulled out
2. "Run" – pushed in

NOTE: DO NOT twist key after it is inserted.

Engine Shutoff Switch

1. Set the engine shutoff switch to the run position ("Run") to start and operate the engine.
2. Set the engine shutoff switch to the stop position ("Stop") to shut off a running engine.

Primer Bulb



Pushing the primer bulb in adds fuel for easier engine start. Refer to *Starting and Shut Off* on page 19.

Speed Selector

Position the speed selector in the appropriate speed notch to control forward and reverse travel.



Forward:

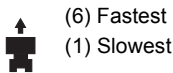

Reverse:

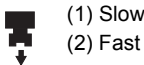

IMPORTANT: DO NOT change motion from forward to reverse with clutch engaged. Forward speed can be changed without declutching.

Fuel Shut-Off Valve

IMPORTANT: The fuel shut-off valve MUST be in the closed position prior to transporting the unit.

The fuel shut-off valve has two positions:

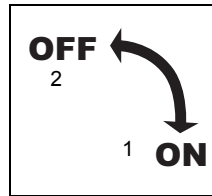

Open (1): Use this position to run the unit.

Closed (2): Use this position to service, transport, or store the unit.

Choke Control

1. Choke Closed position: chokes off air to engine for easier start.
2. Choke Open position: allows for normal operation.

IMPORTANT: Gradually open choke after engine starts.

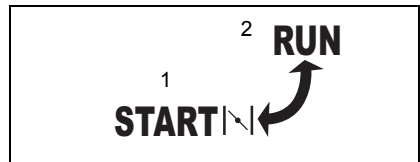

Electric Starter

The electric starter will start a properly choked and cranked engine when the starter button is pushed. Refer to *Starting and Shut Off* on page 19.

Recoil Starter Handle

When pulled, recoil starter handle will turn engine over.

IMPORTANT: DO NOT let recoil starter handle snap back against starter.

See *Starting and Shut Off* on page 19.

Snow Clean-Out Tool

(Figure 14)



WARNING: Hand contact with the rotating impeller is the most common cause of injury associated with snow throwers. Never use your hand to clean out the discharge chute.

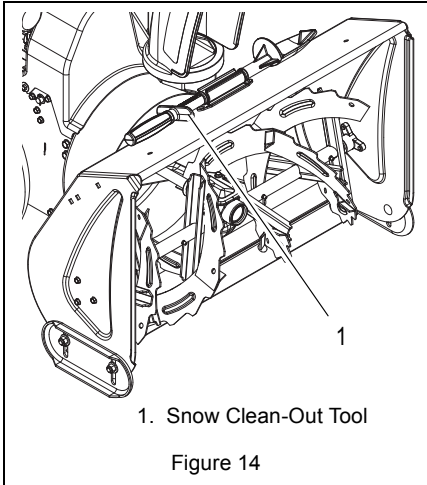

1. Snow Clean-Out Tool

Figure 14

To clear the discharge chute:

1. Shut off engine, remove key, disconnect spark plug wire from spark plug.
2. Wait for impeller blades to stop rotating completely.
3. Remove the snow clean-out tool (1) from the auger housing and use it to remove the clog from the discharge chute.
4. Replace the snow clean-out tool on the auger housing.
5. Reconnect spark plug wire, and restart engine.

Remote Discharge Chute Deflector Control

ALWAYS position discharge chute deflector at a safe angle before starting engine.

DO NOT throw snow any higher than necessary.

Place deflector remote in a forward notch to throw snow lower. Place deflector remote in a rearward notch to throw snow higher.

Discharge Chute

Discharge chute rotates 205°.

ALWAYS position discharge chute in safe direction and angle, away from operator and bystanders, before starting engine.

Discharge Chute Crank

IMPORTANT: If chute does not stay in set position, adjust as directed in *SERVICE AND ADJUSTMENTS* on page 24, or repair before operation.

Rotate the chute with the discharge chute crank handle.

IMPORTANT: DO NOT force frozen chute controls. If frozen, take to warm place until controls are free.

Axle Lock Pin

(Figure 15)

Use the axle lock pin to lock or unlock the right or left wheel. Lock both wheels to increase traction; unlock one wheel to allow for easier turning of the unit.

NOTE: Unit will not drive with both wheels unlocked.

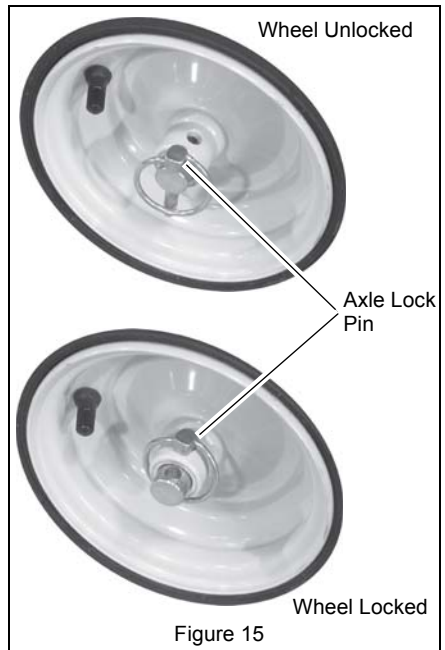

Figure 15

Scraper Blade

The scraper blade allows the back of the housing to keep better contact with the surface being cleared. It also prevents damage to the housing from wear.

IMPORTANT: DO NOT allow Scraper Blade to wear too far or Auger/Impeller housing will become damaged.

Skid Shoes

The skid shoes control the distance between the scraper blade and the ground. Adjust skid shoes equally to keep blade level with the ground. Refer to *Pre-Start* on page 18 for recommended settings.

FILLING FUEL TANK



WARNING: AVOID INJURY. Read and understand the entire *Safety* section before proceeding.

GASOLINE

IMPORTANT: ALWAYS use gasoline that meets the following guidelines:

- Clean, fresh gasoline.
- A minimum of 87 octane/87 AKI (91 RON). High altitude use may require a different octane. Consult your engine manual.
- Gasoline with up to 10% ethanol (gasohol) or up to 10% MTBE (methyl tertiary butyl ether) is acceptable.
- Use of any gasoline other than those approved above will void the engine warranty. If the pumps are not marked for the content of alcohol or ethers, check ethanol and MTBE levels with the fuel supplier.
- Do not modify the fuel system to use different fuels.
- Never mix oil and gasoline.

NOTE: All gasoline is not the same. If the engine experiences starting or performance problems after using a new gasoline, switch to a different fuel provider or fuel brand.

IMPORTANT: Excessively oxygenated or reformulated fuels (fuels blended with alcohols or ethers) can damage the fuel system or cause performance problems. If any undesirable operating problems occur, use a gasoline with a lower percentage of alcohol or ether.

Add Fuel Stabilizer to Extend Fuel Storage Life

IMPORTANT: Fuel stabilizer is recommended for extended storage (see *Fuel System* on page 31).

Add Fuel to Fuel Tank

1. ALWAYS place unit in open or well-ventilated area.
2. Stop engine and allow to cool.
3. Clean Fuel Cap and surrounding area to prevent dirt from entering Fuel Tank.
4. Remove fuel cap.

IMPORTANT: Refer to Engine Manual for correct type and grade of fuel.

5. Fill fuel tank to the bottom of filler neck. See *SPECIFICATIONS* on page 35 for fuel tank capacity.

IMPORTANT: DO NOT OVERFILL! This equipment and/or its engine may include evaporative emissions control system components, required to meet EPA and/or CARB regulations, that will only function properly when the fuel tank has been filled to the recommended level. Overfilling may cause permanent damage to evaporative emissions control system components. Filling to the recommended level ensures a vapor gap required to allow for fuel expansion. Pay close attention while filling the fuel tank to ensure that the recommended fuel level inside the tank is not exceeded. Use a portable gasoline container with an appropriately sized dispensing spout when filling the tank. Do not use a funnel or other device that obstructs the view of the tank filling process.

6. Replace fuel cap and tighten.
7. ALWAYS clean up spilled fuel.

PRE-START

1. Frozen Impeller

IMPORTANT: Before starting engine, check impeller to be sure it is not frozen.

To check impeller:

1. With ignition key switch in "Stop" position, squeeze attachment clutch lever to engaged position.
2. Pull recoil starter handle.
3. If impeller is frozen, (cannot pull recoil starter handle) move unit to a heated area and thaw to prevent possible damage.

2. Check Function of Clutches

If clutches do not engage or disengage properly, adjust or repair before operation. See *Attachment Clutch/Brake Adjustment* on page 26 and *Traction Drive Clutch Adjustment* on page 28.

3. Check Dual Handle Interlock

Without the engine running, press down (engage) both clutch levers. Release attachment clutch lever. Attachment clutch should remain engaged until traction drive clutch lever is released, then both clutches *must* disengage.

If clutches do not engage or disengage properly, adjust or repair before operation. See *Attachment Clutch/Brake Adjustment* on page 26 and *Traction Drive Clutch Adjustment* on page 28.

4. Check Axle Lock Pins

Use the axle lock pins to lock or unlock the wheels. Lock both wheels to increase traction; unlock one wheel to allow for easier turning of the unit.

5. Check Skid Shoes

Check and adjust skid shoes (see *Skid Shoes* on page 24). Allow 1/8 in. (3 mm) between scraper blade and hard, smooth surface(s). Allow 7/8 in. (22 mm) between scraper blade and uneven or gravel surfaces.

6. Check Engine Fuel & Crankcase Oil



WARNING: AVOID INJURY. Read and understand the entire *Safety* section before proceeding.

Check and add fuel if required. Check that the engine crankcase oil is full using dipstick. Refer to engine manual for detailed instructions.

TO STOP IN AN EMERGENCY

Immediately release both clutch levers to stop unit in an emergency. Stop engine, remove key and wait for all rotating parts to stop before leaving operator's position.

STARTING AND SHUT OFF



WARNING: FAILURE TO FOLLOW INSTRUCTIONS could result in personal injury and/or damage to unit. DO NOT attempt to start your unit at this time. Read entire owner/operator manual and the engine manual first.

IMPORTANT: Allow unit and engine to adjust to the outdoor temperature before clearing snow. Before shut-off, run the attachment a few minutes to prevent impeller freeze-up.

NOTE: Try out each control without the engine running to see how it works and what it does.

Manual Start

1. Turn discharge chute straight ahead.
2. Make sure that the attachment clutch and traction drive clutch levers are fully disengaged.
3. Push primer bulb 2 or 3 times for cold engine.

NOTE: When temperature is below -15° F (-26° C) additional priming may be needed.

4. If engine is cold, apply choke. See engine manual for detailed instructions.

NOTE: A warm engine requires less choking than a cold engine.

5. Insert key into ignition switch on engine and push into RUN position. DO NOT twist key after it is inserted.
6. Turn on the engine shutoff switch ("Run").
7. Grasp recoil starter handle and pull rope out slowly until it pulls harder. Let rope rewind slowly.
8. Pull rope with a rapid continuous full arm stroke. Let rope rewind slowly.

IMPORTANT: DO NOT let recoil starter handle snap against starter.

9. Repeat steps 7 and 8 until engine starts. (If engine does not start, refer to *TROUBLESHOOTING* on page 33.)
10. Adjust choke as needed.

Electric Start (120V)

1. Connect extension cord to starter.

IMPORTANT: Prevent damage to unit. Know voltage of your starter and only use matching outlets.

2. Plug extension cord into 120V 3-wire, grounded outlet.

IMPORTANT: Use an extension cord that is capable of handling current requirements. Cord should be rated for a minimum of 13 amps, grounded, UL listed, CSA certified and labeled as suitable for outdoor use.

3. Turn discharge chute straight ahead.
4. Make sure that the attachment clutch and traction drive clutch levers are fully disengaged.
5. Push Primer Bulb 2 or 3 times for cold engine.

NOTE: When temperature is below -15° F (-26° C) additional priming may be needed.

6. If engine is cold, apply choke. See Engine Manual for detailed instructions.

NOTE: A warm engine requires less choking than a cold engine.

7. Insert key into ignition switch on engine and push into RUN position. DO NOT twist key after it is inserted.
8. Turn on the engine shutoff switch ("Run").
9. Press starter button on engine until engine starts.

IMPORTANT: DO NOT operate starter more than 15 seconds per minute, as overheating and damage can occur. (If engine does not start, refer to *TROUBLESHOOTING* on page 33.)

10. Adjust choke as needed.
11. Disconnect power cord from outlet, then starter.

Shut Off

1. Release traction drive clutch lever and allow unit to come to a complete stop.
2. Run impeller a few minutes after use to prevent freeze-up of impeller.
3. Release attachment clutch lever and wait for all moving parts to come to a complete stop.
4. Turn off the engine shutoff switch ("Stop").
5. Remove key.

SNOW REMOVAL

IMPORTANT: Allow unit and engine to adjust to the outdoor temperature before clearing snow.

NOTE: Attachment clutch should be engaged before traction drive clutch when throwing snow.

1. Select speed control position and direction.
2. Engage attachment clutch – right hand lever.
3. Engage traction drive clutch – left hand lever.

IMPORTANT: DO NOT overload unit capacity by attempting to clear snow at too fast a rate. Use slow speed to clear deep or hard packed snow.

Tips for Operation

Snow is best removed as soon as possible after snow fall.

To clear an area, run unit in an overlapping series of paths. For large areas, start in the middle and throw snow to each side, so snow is not cleared more than once.

ALWAYS direct snow away from area to be cleared and with direction of the wind.

TRAVELING

To travel from one work area to another:

1. Press down on handlebars enough to raise front of unit slightly off surface.
2. Engage traction drive clutch without engaging attachment clutch.

TRANSPORT

ALWAYS shut off engine, remove key, and close fuel shut-off valve when transporting unit on a truck or trailer.

Use extra care when loading or unloading unit onto trailer or truck.

Secure unit chassis to transport vehicle. NEVER secure from rods or linkages that could be damaged.

DO NOT transport machine while engine is running.

MAINTENANCE

Ariens dealers will provide any service or adjustments which may be required to keep your unit operating at peak efficiency. Should engine service be required, contact an Ariens dealer or an authorized engine manufacturer's service center.



WARNING: AVOID INJURY. Read and understand the entire *Safety* section before proceeding.

SERVICE POSITION

(Figure 16)



WARNING: Before tipping unit up onto housing, close fuel shut-off valve, and drain fuel tank and fuel system so no spills will occur (see engine manual for complete instructions). Ensure unit is secure and will not tip over during maintenance.

Place unit on a flat level surface. Tip unit forward onto front of auger housing for service. Ensure unit is secure and will not tip over. Strap and clamp onto bench if needed.

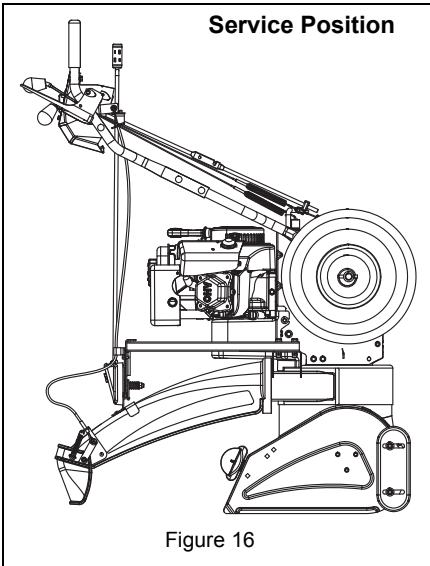

MAINTENANCE SCHEDULE

The chart below shows the recommended maintenance schedule that should be performed on a regular basis. More frequent service may be required.

MAINTENANCE SCHEDULE

| Service Performed | Each Use | Every 5 hrs. | Every 25 hrs. | Yearly |
|--------------------------------|----------|--------------|---------------|--------|
| Check Dual Handle Interlock | • | | | |
| Check Fasteners | • | | | |
| Check Clutch Operation | • | | | |
| Check Clutch Cable Adjustments | | * | • | |
| Clean Engine | • | | | |
| Check Engine Oil | | • | | |
| Change Engine Oil** | | | | |
| Check Tire Pressure | | | • | |
| Check Auger Gearcase | | | • | • |
| General Lubrication | | | • | • |

* After first 5 hours of operation.

** Refer to Engine Manual for detailed instructions.

CHECK DUAL HANDLE INTERLOCK

Without the engine running, press down (engage) both clutch levers. Release attachment clutch lever. Attachment clutch should remain engaged until traction drive clutch lever is released, then both clutches *must* disengage.

CHECK FASTENERS

Make sure all hardware is tightened properly.

CHECK CLUTCH OPERATION

Auger / impeller must stop within 5 seconds when attachment clutch lever is released.

Wheels must stop quickly when traction drive clutch lever is released.

If clutches do not engage or disengage properly, adjust or repair before operation. See *Attachment Clutch/Brake Adjustment* on page 26 and *Traction Drive Clutch Adjustment* on page 28.

CHECK CLUTCH CABLE ADJUSTMENT

Make sure the attachment clutch and traction drive clutch are adjusted as specified in *Attachment Clutch/Brake Adjustment* on page 26 and *Traction Drive Clutch Adjustment* on page 28.

CLEAN ENGINE

Refer to engine manual for detailed instructions.

CHECK ENGINE OIL

The engine crankcase oil should be checked every 5 hours of operation. Oil level MUST be maintained in safe operating range on dipstick at all times or engine damage will result (See engine manual).

Park unit on a level surface. Refer to engine manual for detailed instructions.

CHANGE ENGINE OIL

Refer to engine manual for detailed instructions.

NOTE: Run engine just prior to changing oil, warm oil will flow more freely and carry away more contaminants.

CHECK TIRE PRESSURE

Keep tires at pressure listed on the tire sidewall (see *Check Tire Pressure* on page 13).

CHECK AUGER GEARCASE

(Figure 17)

IMPORTANT: Proper oil level must be maintained.

Gear cases are filled to the correct level at the factory. Unless there is evidence of leakage, no additional lubricant should be required. Check oil level each season or every 25 hours of operation.

IMPORTANT: Be sure unit is resting on a level surface before checking lubricant levels.

To ensure adequate lubricant level:

1. Remove oil fill plug and seal washer (Figure 17). Lubricant must be 1.63 in. – 1.88 in. (4.14 cm – 4.78 cm) from the flat surface of the gear case cover.

IMPORTANT: DO NOT remove the gear case cover.

2. Check oil level with suitable dipstick device. Add lubricant if required.

NOTE: Inspect seal washer for wear or rubber deterioration and replace as needed.

IMPORTANT: Use only Ariens L3 synthetic severe duty gear lube (Part Number 00068800). Use of other lubricants will void unit warranty.

3. Reinstall oil fill plug and seal washer to 80 lbf-in. (9 N•m).

IMPORTANT: DO NOT OVER-TORQUE! Note that measurements are in pound force inches (lbf-in) and NOT pound force foot (lbf-ft).

IMPORTANT: Be sure to install seal washer with rubber side down (Figure 17).

IMPORTANT: Improper torquing, omission of seal washer, or incorrect installation of seal washer will void unit warranty.

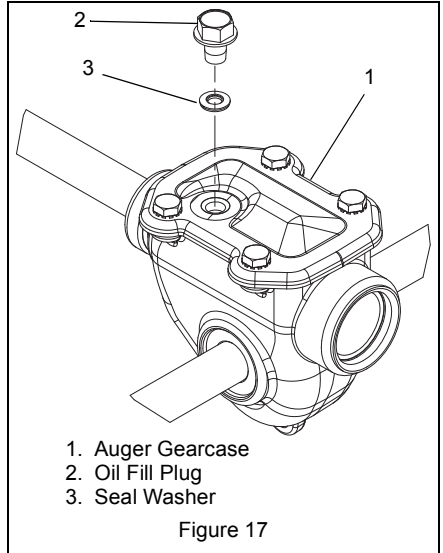

Figure 17

GENERAL LUBRICATION

(Figure 18)

IMPORTANT: Wipe each fitting clean before and after lubrication.

IMPORTANT: DO NOT allow grease or oil to get on friction disc, friction plate or belts.

NOTE: Apply Ariens Hi-Temp Grease or equivalent to the lubrication fittings. See *SERVICE PARTS* on page 32.

The unit should be lubricated (Figure 18) at beginning of season or every 25 operating hours.

Auger Shaft

NOTE: To grease auger shaft, remove shear bolt nuts, and shear bolts. Apply grease at the grease zerks and then turn the auger assemblies on the auger shaft. Replace shear bolts per instructions in *Shear Bolts* on page 24.

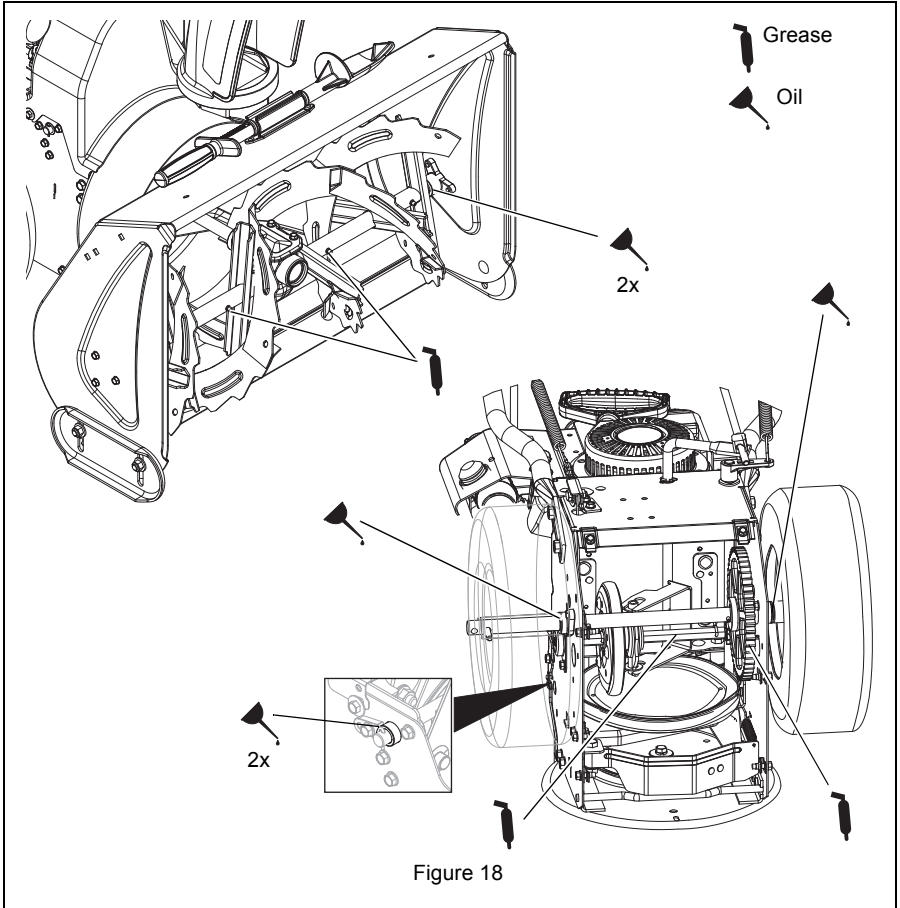

SERVICE AND ADJUSTMENTS



WARNING: AVOID INJURY. Read and understand the entire *Safety* section before proceeding.

SCRAPER BLADE

IMPORTANT: Damage to housing will result if blade wears down too far.

Scraper blade is adjustable to compensate for wear.

To adjust scraper blade:

1. Tip unit back onto handlebar, support housing and loosen nuts retaining blade.
2. Lower scraper blade to compensate for wear then tighten nuts.
3. Adjust skid shoes.

IMPORTANT: ALWAYS adjust skid shoes after adjusting scraper blade to prevent premature wear to scraper blade or damage to housing.

SKID SHOES

(Figure 19)

IMPORTANT: Skid shoes should be adjusted as conditions require. Allow 1/8 in. (3 mm) between scraper blade and hard smooth surfaces. Allow 7/8 in. (22 mm) between scraper blade and uneven or gravel surfaces.

1. Position unit on a hard, flat, smooth, level surface.
2. Adjust skid shoes by inserting a spacer of desired thickness under center of scraper blade, loosen skid shoe hardware.
3. Slide skid shoe to flat surface.

NOTE: Be sure to keep housing level by adjusting skid shoes equally.

4. Tighten skid shoe hardware.

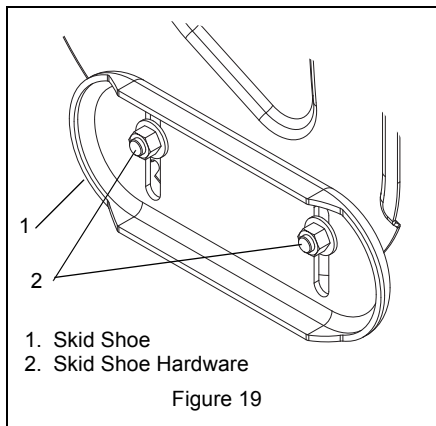

SHEAR BOLTS

(Figure 20)

IMPORTANT: Use only Ariens OEM shear bolts for replacement. Use of any other type of shear bolt may result in severe damage to unit and may void the warranty.

Occasionally a foreign object may enter the auger/impeller housing and jam the auger, breaking shear bolts which secure the auger to the shaft. This allows auger to turn freely on the shaft which may help prevent damage to gear case and its components.

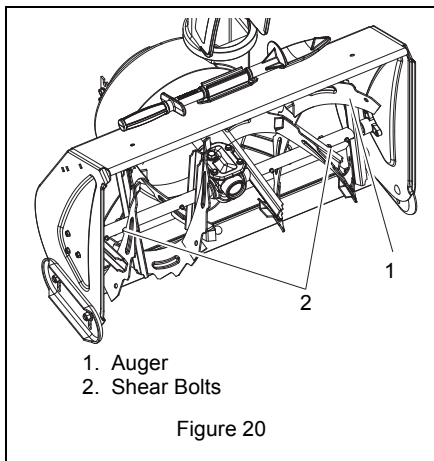

For Replacement:

1. Align shear bolt holes in auger with shear bolt holes in the shaft.
2. Drive shear bolt through hole (if shear bolt was broken this will drive remaining part from shaft).
3. Secure shear bolt with nut.

NOTE: DO NOT overtighten the shear bolt. Tighten shear bolt to 5.8 – 12.2 lbf-ft (7.9 – 16.5 N•m).

REMOTE DISCHARGE DEFLECTOR CONTROL ADJUSTMENT

(Figures 21 and 22)

Deflector must stay in selected position while throwing snow.

If deflector does not stay in set position:

1. Tighten nut beneath control panel to increase pressure on deflector control (Figure 21).

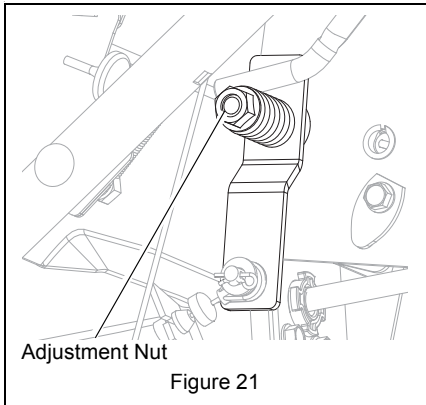

If deflector does not follow full range of travel:

1. Push deflector remote all the way to rear most position.
2. Loosen adjusting nuts on remote deflector control cable attached to the chute (Figure 22).
3. To adjust the deflector lower:
Loosen bottom adjustment nut and tighten top adjustment nut.
To adjust deflector higher:
Loosen top adjustment nut and tighten bottom adjustment nut.
4. Check the deflectors range of travel and repeat adjustment as necessary.

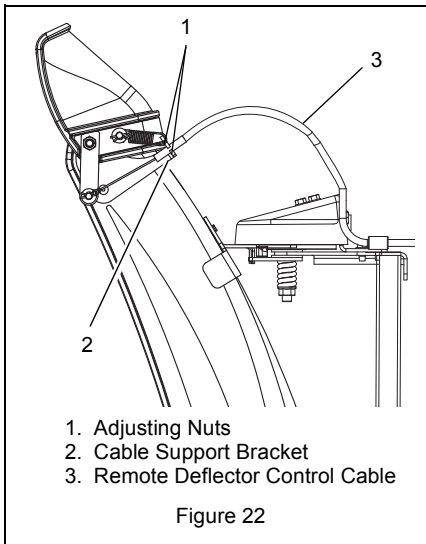

DISCHARGE CHUTE

(Figure 23)

If discharge chute does not stay in position while operating, tighten nut on carriage bolt at pivot point to increase tension on spring.

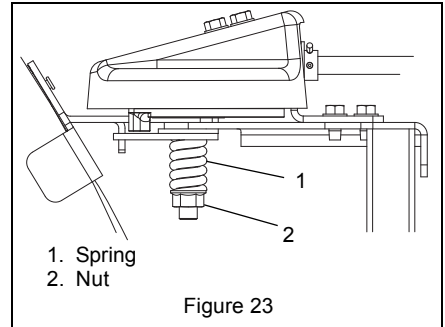

SPEED SELECTOR ADJUSTMENT

(Figure 24)

To adjust:

1. Disconnect adjustment pivot pin from speed selector arm. Save hardware for reinstallation.
2. Place the speed selector on control panel in the fastest forward speed position.
3. Turn the speed selector arm straight down towards the ground as far as it will go.
4. Thread the adjustment pivot pin along the shift rod until it aligns with the mating hole on the speed selector arm, and then turn it up the shift rod 7 turns. Insert the pivot pin into hole.
5. Connect the pivot pin to the speed selector arm with the hardware removed in step 1.
6. Check forward and reverse speeds:
 - a. Start unit.
 - b. Shift speed selector into the first forward speed.
 - c. Engage the traction drive clutch. Unit should move forward.
 - d. Stop unit.
 - e. Shift speed selector into first reverse speed.
 - f. Engage the traction drive clutch. Unit should move backward.
 - g. Shut off unit.
7. Adjust pivot pin on the shift rod as necessary so unit travels forward when speed selector is in first forward position and travels backward when speed selector is in first reverse position.
8. Connect the pivot pin to the speed selector arm with the hardware removed in step 1.

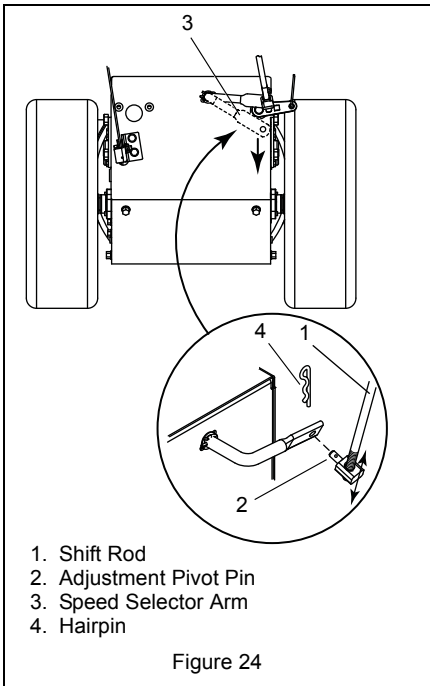

ATTACHMENT CLUTCH/BRAKE ADJUSTMENT



WARNING: IMPROPER ADJUSTMENT could result in unexpected movement of auger and impeller causing death or serious injury. **AUGER / IMPELLER MUST STOP** within 5 seconds when attachment clutch lever is released.



WARNING: Adjustment procedure requires the engine to be run with the belt cover off. **AVOID INJURY.** Read and understand the entire *Safety* section before proceeding.

Remove Attachment Cable Slack

(Figures 25 and 26)

1. Shut off engine, remove key, disconnect spark plug wire and allow unit to cool completely.
2. Loosen hardware securing belt cover to unit.

NOTE: DO NOT completely remove hardware from unit.

3. Remove belt cover.

4. Loosen jam nut on cable adjustment barrel, and then turn the adjustment barrel down to shorten cable and remove all cable slack (Figure 25).

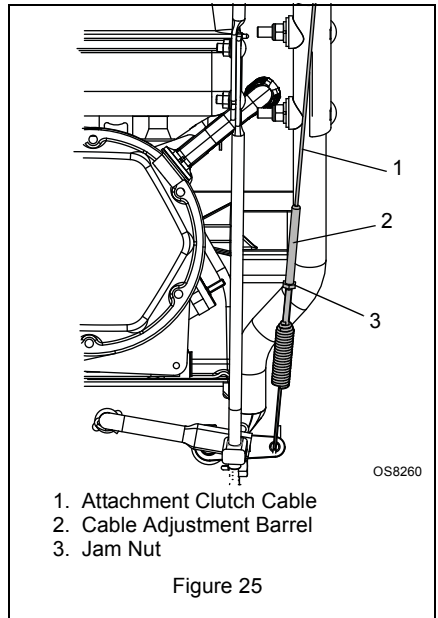

5. With the attachment clutch disengaged, check that the attachment idler arm lightly touches the frame (Figure 26).
6. Tighten jam nut on cable adjustment barrel.

With the attachment clutch disengaged, check the attachment idler arm position here. The attachment idler arm should lightly touch the frame.

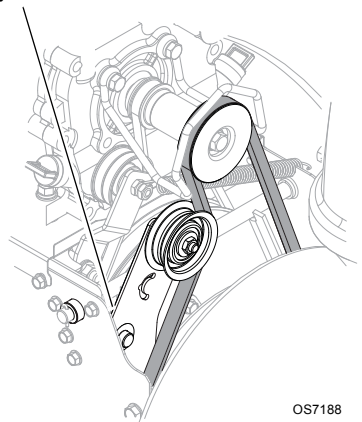

Figure 26

Check Attachment Idler Arm Roller Clearance

(Figures 27 and 28)

1. Place the unit into the service position. Remove the bottom cover.
2. With the attachment clutch lever engaged, check the clearance between the frame and plastic roller on the lower end of the attachment idler arm (Figure 27).

Roller should be $1/2 - 7/8$ in. (12.7 – 22.2 mm) from the frame when the attachment clutch is engaged.

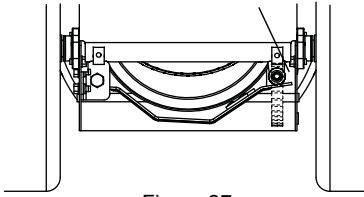
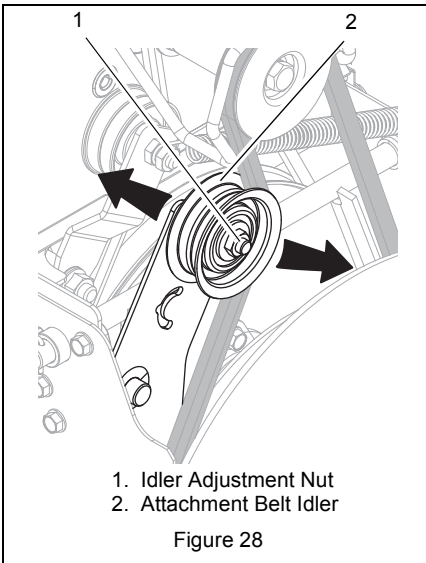

Figure 27

OS8260

- If roller is $1/2 - 7/8$ in. (12.7 – 22.2 mm) from frame, no further adjustment is required.
- If roller is less than $1/2$ in. (12.7 mm) from frame, loosen idler adjustment nut and move idler closer to the belt. Tighten adjustment nut and recheck the roller clearance (Figure 28).
- If roller is more than $7/8$ in. (22.2 mm) from frame, loosen idler adjustment nut and move idler away from the belt. Tighten adjustment nut and recheck roller clearance (Figure 28).



1. Idler Adjustment Nut
2. Attachment Belt Idler

Figure 28

Check Attachment Brake

(Figure 29)

1. With the attachment clutch lever disengaged, brake pad must contact attachment belt. With attachment clutch lever engaged, brake pad must be more than $1/16$ in. (1.6 mm) from belt. If there is more than $1/16$ in. (1.6 mm) gap, go to *Check Belt Finger Clearance* on page 27. If there is less than $1/16$ in. (1.6 mm) gap, go to Step 2.

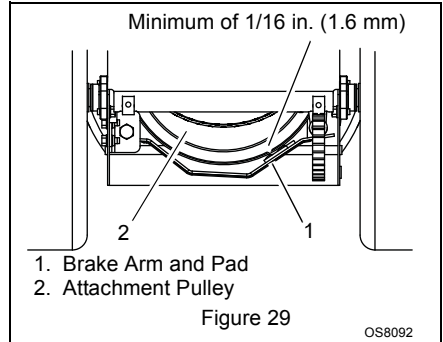

1. Brake Arm and Pad
2. Attachment Pulley

Figure 29

OS8092

2. If there is less than $1/16$ in. (1.6 mm) gap between brake pad and belt:
 - a. Loosen idler adjustment nut, and move idler away from belt. Position idler to achieve a $1/16$ in. (1.6 mm) minimum brake pad gap and a $1/2 - 7/8$ in. (12.7 – 22.2 mm) gap between the plastic roller and the frame.

IMPORTANT: If adjustments cannot be brought into specified ranges see your dealer for repairs.

Check Belt Finger Clearance

(Figure 30)

1. With attachment clutch lever engaged, the belt finger located opposite the belt idler must be less than $1/8$ in. (3.2 mm) from belt, but not touching the belt. To adjust belt finger, loosen the bolts and move the finger to the proper position. Tighten the bolts and recheck the belt finger clearance.
2. Replace the belt cover and tighten hardware.

Check belt finger clearance here. With the attachment clutch engaged, there should be less than 1/8 in. (3.2 mm) clearance between the belt and the belt finger. The belt finger should not touch the belt.

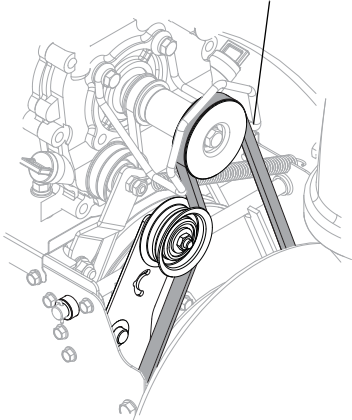

Figure 30

OS8067

TRACTION DRIVE CLUTCH ADJUSTMENT

If drive slips, adjust traction clutch to compensate for friction disc wear.

1. Loosen jam nut on traction cable adjustment barrel. Turn adjustment barrel down to shorten cable and remove all cable slack.
2. With traction clutch disengaged, check that swing gate finger touches the side of stop hole closest to auger housing (Figure 34).

IMPORTANT: Finger **MUST** touch side of stop hole. Readjust cable as necessary until finger touches stop hole.

ATTACHMENT DRIVE BELT REPLACEMENT

Remove Attachment Drive Belt

(Figures 31, 32 and 33)

1. Shut off engine, remove key, disconnect spark plug wire and allow unit to cool completely.
2. Loosen hardware securing belt cover to unit.

NOTE: DO NOT completely remove hardware from unit.

3. Remove belt cover.
4. Remove spring clip pin from chute crank and separate.
5. Remove remote deflector control cable from control lever.

6. Remove belt finger by removing cap screws mounting belt finger to engine (Figure 32 or 33).
7. Remove attachment drive belt from engine sheave (it may be necessary to turn engine sheave using recoil starter handle).



CAUTION: Always support the unit frame and housing when loosening the cap screws holding them together. Never loosen cap screws while unit is in service position.

IMPORTANT: To avoid bending bottom cover, when tipping unit apart, support handlebars firmly or tip unit up on housing and remove bottom cover by removing six cap screws before separating unit.

8. Support the frame and housing.
9. Remove hex bolts securing housing to frame (two on each side). Tip housing and frame apart on pivot pin.
10. Separate housing from unit.
11. Remove attachment drive belt from attachment pulley.

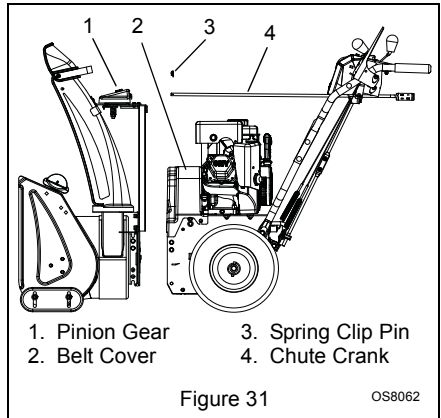

- | | |
|----------------|--------------------|
| 1. Pinion Gear | 3. Spring Clip Pin |
| 2. Belt Cover | 4. Chute Crank |

Figure 31

OS8062

Replace Attachment Drive Belt

1. Place new belt onto attachment pulley (Figure 32).

NOTE: Engage attachment clutch lever while connecting housing to frame to hold brake out of the way.

2. Tip housing and frame back together and secure with hex bolts.
3. Place belt onto engine sheave.
4. Replace belt finger.

IMPORTANT: With the attachment clutch lever engaged, the belt finger located opposite the belt idler must be less than 1/8 in. (3.2 mm) from the belt, but not touching the belt, or belt grabbing may occur causing impeller to rotate while the attachment clutch is disengaged (Figure 33).

- Adjust clutch per *Attachment Clutch/Brake Adjustment* on page 26.



WARNING: AVOID INJURY. Auger must stop within 5 seconds when attachment lever is released or serious injury or unit damage may result.

- Replace chute crank and secure with spring clip pin.
- Reconnect remote deflector cable to control lever.
- Run in the attachment belt. See *Run-in Attachment Belt* on page 13.
- Replace belt cover and tighten hardware.

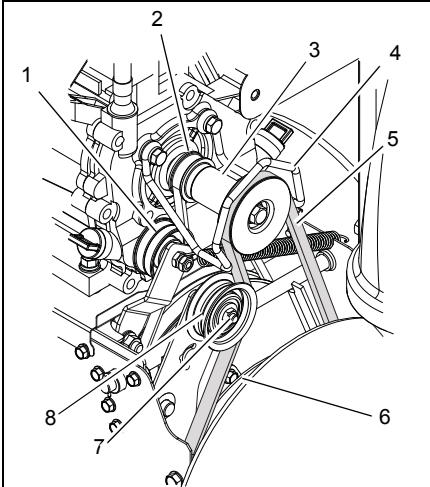

- Traction Belt Idler
- Traction Drive Belt
- Engine Sheave
- Belt Finger
- Attachment Drive Belt
- Attachment Pulley
- Attachment Idler Nut
- Attachment Belt Idler

Figure 32

OS8160

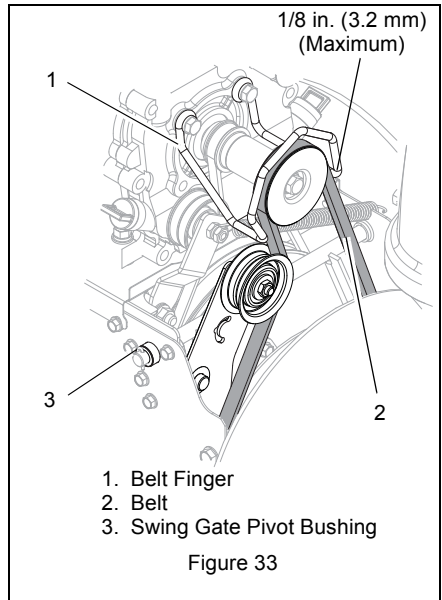

- Belt Finger
- Belt
- Swing Gate Pivot Bushing

Figure 33

TRACTION DRIVE BELT REPLACEMENT

(Figure 34)

NOTE: Housing and frame must be tipped apart and attachment drive belt removed from engine sheave in order to change traction drive belt.



CAUTION: Always support the unit frame and blower housing when loosening the cap screws holding them together. Never loosen cap screws while unit is in service position.

- Remove attachment drive belt (See *Remove Attachment Drive Belt* on page 28).
- Detach traction idler spring.
- Remove swing gate spacer.
- Slide swing gate to the left until finger is out of the frame.

NOTE: The drive plate is detached to create space between the drive plate and friction disc to remove and reinstall the belt.

- Remove traction drive belt.

NOTE: To remove belt it may be necessary to turn engine sheave using recoil starter handle.

FRICITION DISC REPLACEMENT

Remove Friction Disc

(Figures 35 and 36):

1. Shut off engine, remove key, disconnect spark plug wire and allow unit to cool completely.



CAUTION: Before tipping unit, remove enough fuel so that no spills occur.

2. Place the unit into the service position on a level surface.
3. Remove lockpins from wheel axles and remove wheels.
4. Remove bottom cover by removing six hex bolts.
5. Disconnect adjustment pivot pin from the speed selector arm. Save the hardware for reinstallation.

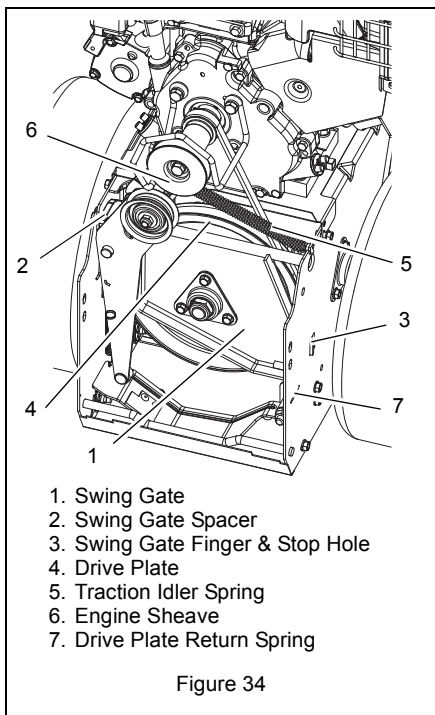

Figure 34

6. Install new traction drive belt.
7. Swing drive plate toward friction disc until finger lines up with stop hole in frame. Slide the drive plate over, inserting the finger into the stop hole.
8. Reinstall swing gate spacer
9. Reinstall traction idler spring.

NOTE: Make sure drive plate return spring remains connected to the frame and drive plate. Make sure the swing gate pivot bushing is piloted in the pivot hole in the frame

10. Replace attachment drive belt (See *Replace Attachment Drive Belt* on page 28).

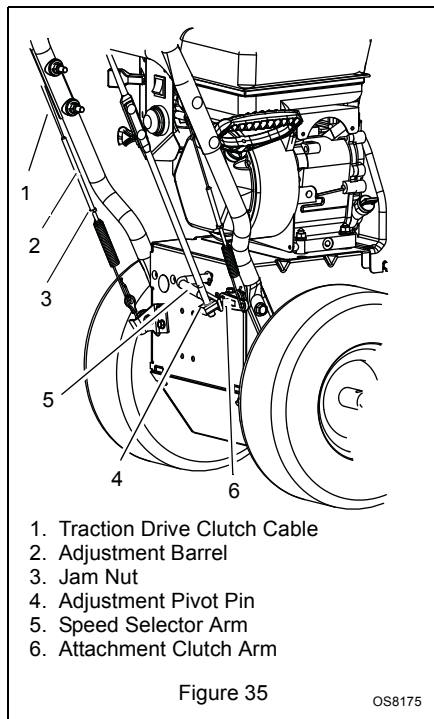

Figure 35

OS8175

6. Remove spring clip pin nearest drive gear from hex shaft.
7. Remove left bearing flange from frame.
8. Slide hex shaft to the left to remove the flat washer, pinion gear and friction disc assembly from the hex shaft.

NOTE: Be sure to save washers between carrier bearing and speed selector arm for reassembly.

9. Remove friction disc assembly from frame.
10. Remove three screws holding friction disc to carrier bearing.
11. Remove old friction disc. Put the new friction disc in place, cup side to carrier bearing.
12. Reinstall three screws into new friction disc and carrier bearing. Torque to 5 – 6 lbf-ft. (6.8 – 8.1 N•m).

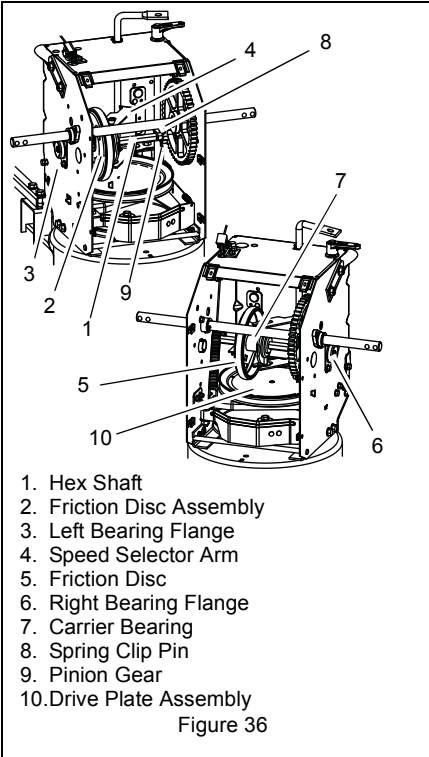

1. Hex Shaft
2. Friction Disc Assembly
3. Left Bearing Flange
4. Speed Selector Arm
5. Friction Disc
6. Right Bearing Flange
7. Carrier Bearing
8. Spring Clip Pin
9. Pinion Gear
10. Drive Plate Assembly

Figure 36

13. Insert new friction disc assembly into frame. Install washers onto carrier bearing and slide into speed selector arm.
14. Slide hex shaft through new friction disc assembly. Install pinion gear and washer onto hex shaft and slide shaft into right bearing.
15. Install left bearing flange using hardware removed in step 7.
16. Reinstall spring clip pin into hex shaft.
17. Connect adjustment pivot pin to speed selector arm. See *Speed Selector Adjustment* on page 25.
18. Install bottom cover.
19. Reinstall wheels.
20. Return unit to upright position.
21. Connect spark plug wire to spark plug.
22. Adjust traction drive clutch. See *Traction Drive Clutch Adjustment* on page 28.

STORAGE



WARNING: AVOID INJURY. Read and understand the entire *Safety* section before proceeding.

SHORT TERM

IMPORTANT: NEVER spray unit with high pressure water or store unit outdoors. Run with attachment clutch engaged a few minutes after each use to free unit of any loose or melting snow.

Close fuel shut-off valve.

Inspect unit for visible signs of wear, breakage or damage.

Keep all nuts, bolts and screws properly tightened and know unit is in safe working condition.

Store unit in a cool, dry protected area.

LONG TERM

Clean unit thoroughly with mild soap and low pressure water and lubricate (see *MAINTENANCE* on page 21). Touch up all scratched painted surfaces.

Remove weight from wheels by putting blocks under frame or axle.

FUEL SYSTEM

Gasoline left in the fuel system for extended periods without a stabilizer will deteriorate, resulting in gum deposits in the system.

These deposits can damage the carburetor and the fuel hoses, filter and tank. Prevent deposits from forming in the fuel system during storage by adding a quality fuel stabilizer to the fuel. Follow the recommended mix ratio found on the fuel stabilizer container.

IMPORTANT: NEVER store the engine with fuel in the fuel tank inside of a building with potential sources of ignition.

Add Fuel Stabilizer

1. Turn the fuel valve off while engine is running and allow the engine to run until it stops. Turn engine OFF when it begins surging to avoid engine damage.
2. Add fuel stabilizer, following the manufacturer's instructions.
3. Turn fuel valve on after adding fuel stabilizer.
4. Re-start engine.
5. Run the engine outdoors for 5 minutes to be sure that treated gasoline has replaced the untreated gasoline in the carburetor.
6. Slow the engine to an idle speed.
7. Repeat step 1 above.

SERVICE PARTS

Order the following parts through your dealer:

| Part No. | Description |
|----------|---|
| 00036800 | Ariens Hi-Temp Grease (3.3 oz. cartridges) |
| 21547400 | Spark Plug |
| 07200513 | Impeller Belt |
| 07200603 | Traction Belt |
| 53200500 | Shear Bolts |
| 00170800 | Friction Disc |
| 00592900 | Gas Stabilizer (4 oz.) |
| 06400920 | Gear Case Seal Washer |

ACCESSORIES

See your authorized Ariens dealer to add the additional accessories available to your Sno-Tek model.

| Part No. | Description |
|----------|--------------------------|
| 72000200 | Slicer Bar |
| 72406500 | Front Weight Kit |
| 72601400 | Snow Thrower Cover |
| 72408000 | Snow Cab Kit |
| 72001300 | Composite Skid Shoes Kit |

TROUBLESHOOTING

| PROBLEM | PROBABLE CAUSE | CORRECTION |
|---|--|--|
| Engine will not crank/start. | <ol style="list-style-type: none"> 1. Fuel tank is empty. 2. Fuel shut-off valve closed. 3. Build up of dirt and residue around governor/carburetor. 4. Key switch not in run position. 5. Engine start switch turned off. 6. Electric starter not functioning | <ol style="list-style-type: none"> 1. Fill fuel tank. DO NOT OVERFILL! (see <i>Filling Fuel Tank</i> on page 18). 2. Open fuel shut-off valve. 3. Clean area around governor/carburetor. 4. Put Key switch into run position. 5. Turn switch on. See <i>Starting and Shut Off</i> on page 19. 6. Check for bad starter connections. |
| Engine stops. | <ol style="list-style-type: none"> 1. Out of fuel. 2. Fuel shut-off valve closed. 3. Mechanical jam in auger or impeller. 4. Contaminated fuel supply. 5. Faulty spark plug. 6. Plugged fuel cap vent. | <ol style="list-style-type: none"> 1. Fill fuel tank. DO NOT OVERFILL! (see <i>Filling Fuel Tank</i> on page 18). 2. Open fuel shut-off valve. 3. Turn off engine, remove key, and wait for all moving parts to stop. Check for and remove obstruction and repair before restart. 4. Replace with clean fuel. 5. Replace or clean spark plug. 6. Replace fuel cap. |
| Engine problems. | <ol style="list-style-type: none"> 1. See Engine Manual. | <ol style="list-style-type: none"> 1. See Engine Manual. |
| Does not operate in Forward / Reverse. | <ol style="list-style-type: none"> 1. Friction disc worn out. 2. Traction belt not functioning. 3. Speed selector not adjusted properly. | <ol style="list-style-type: none"> 1. Replace friction disc (see <i>Friction Disc Replacement</i> on page 30). 2. Repair or replace traction drive belt (see <i>Traction Drive Belt Replacement</i> on page 29). 3. Adjust speed selector (see <i>Speed Selector Adjustment</i> on page 25). |
| Small rubber beads collect in frame | <ol style="list-style-type: none"> 1. Friction disc wear. | <ol style="list-style-type: none"> 1. Normal friction disc wear. Chunks or large pieces of rubber mean friction disc should be checked and replaced as necessary. |

TROUBLESHOOTING

| PROBLEM | PROBABLE CAUSE | CORRECTION |
|---|---|---|
| <p>Unit throws snow poorly or does not throw snow.</p> | <ol style="list-style-type: none"> 1. Shear bolts broken. 2. Attachment clutch/brake not adjusted properly. 3. Impeller is frozen in place. 4. Ice or debris is obstructing auger. 5. Attachment drive belt slipping, worn or damaged. | <ol style="list-style-type: none"> 1. Replace shear bolts (<i>see Shear Bolts</i> on page 24). 2. Adjust attachment clutch/brake (<i>see Attachment Clutch/Brake Adjustment</i> on page 26). 3. Move unit to a warm place to thaw. 4. With the engine off and auger disengaged, check for obstructions and remove. 5. Adjust or replace attachment drive belt. To adjust belt see <i>Attachment Clutch/Brake Adjustment</i> on page 26. To replace belt see <i>Attachment Drive Belt Replacement</i> on page 28. |
| <p>Unit runs briefly then stops.</p> | <ol style="list-style-type: none"> 1. A build up of fumes in the fuel tank is creating too much pressure in the fuel tank. | <ol style="list-style-type: none"> 1. Carefully loosen the cap to the fuel tank. |

SPECIFICATIONS

| | | |
|--|-------------------------|-------------------------|
| Model Number | 920402 | 920403 |
| Description | Sno-Tek 24 | Sno-Tek 28 |
| Engine | LCT Storm Force | LCT Storm Force |
| Gross Torque* – ft-lbs (N•m) | 9.5 (12.75) | 9.5 (12.75) |
| *Engine output stated in gross torque per SAE J1940 as rated by engine manufacturer. | | |
| Displacement – in. (cc) | 12.7 (208) | 12.7 (208) |
| High Idle – RPM (min) | 3600 ± 50 | 3600 ± 50 |
| Start | 120 V | 120 V |
| Fuel Tank Capacity – qt (Liters) | 2.9 (2.7) | 2.9 (2.7) |
| Chute | | |
| Chute Rotation Angle | 205° | 205° |
| Rotation Control | 2.5X Quick Turn | 2.5X Quick Turn |
| Deflector Control | Remote | Remote |
| Auger | | |
| Snow Clearing Width – in. (cm) | 24.0 (61.0) | 28.0 (71.1) |
| Gear Case | Aluminum | Aluminum |
| Auger Diameter – in. (cm) | 11.0 (27.9) | 11.0 (27.9) |
| Impeller | | |
| Impeller Diameter – in. (cm) | 12.0 (30.5) | |
| Impeller Speed (RPM) | 1190 | |
| Impeller Tip Speed – ft/sec (m/s) | 62.3 (19.0) | |
| Drive | | |
| Blower Drive | HA Belt | HA Belt |
| Drive System | Disc-O-Matic® | Disc-O-Matic® |
| Speeds | 6 Forward and 2 Reverse | 6 Forward and 2 Reverse |
| Axle Control | Pin-Lock | Pin-Lock |
| Pneumatic Tires – in. | 13 x 4.10-6 | 15 x 5.00-6 |
| Size and Weight | | |
| Length – in. (cm) | 51.9 (131.8) | 50.8 (129.0) |
| Height – in. (cm) | 43.3 (110.0) | 45.4 (115.3) |
| Width – in. (cm) | 26.4 (67.1) | 30.4 (77.2) |
| Weight – lbs (Kg) | 180 (81.6) | 189 (85.7) |



Sno-Thro[®], Sno-Tek[®] and Chore Performing Equipment Limited Warranty

Ariens Company (Ariens) warrants to the **original purchaser** that Ariens, Gravely, Parker, and Countax brand chore performing equipment (including Sno-Thro[®] and Sno-Tek[®] equipment) purchased on or after 1/1/2012 will be free from defects in material and workmanship for the time period noted in the chart below. Equipment put to personal use around a single household or residence is considered "Consumer Use"; equipment put to any business use (agricultural, commercial, or industrial) or used at multiple locations is considered "Commercial Use." If any product is rented or leased, then the duration of these warranties shall be 90 days after the date of purchase.

An authorized Ariens dealer (Ariens brand products), Gravely dealer (Gravely brand products), Parker dealer (Parker brand products), or Countax dealer (Countax brand products) will repair any defect in material or workmanship, and repair or replace any defective part, subject to the conditions, limitations and exclusions set forth herein. Such repair or replacement will be free of charge (labor and parts) to the original purchaser except as noted below.

| Warranty Code | Product Group | Warranty Period Consumer Use | Warranty Period Commercial Use |
|---------------|---|------------------------------|--------------------------------|
| PA | Log Splitters, Brushes, String Trimmers, Edgers | 3 Years | 90 Days |
| PB | Professional Powered Brushes | 3 Years | 1 Year |
| PC | Tillers | 2 Years | 90 Days |
| PD | Vacuums, Blowers, Sweepers, Truck Loaders, Lawn Rakes, Sprayers, Aerators, etc. | 1 Year | 1 Year |
| PE | Pressure Washer, Generators | 3 Years | 1 Year |
| SA | Professional Sno-Thro [®] | 3 Years | 1 Year |
| SB | Compact, Deluxe, Platinum, AMP [™] Sno-Thro [®] | 3 Years | 90 Days |
| SC | Sno-Tek [®] | 2 Years | 90 Days |
| UA | Utility Vehicles | 1 Year | 1 Year |
| N/A | Service (Replacement) Parts | 90 Days (no labor) | 90 Days (no labor) |

Special Extensions

The chart below details special extensions to this warranty:

| Warranty Code | Warranty Exception | Warranty Period | Use | Detail |
|---------------|--|-----------------|----------|---|
| SA | Cast Iron Auger Gear Case | 5 Years | All | 5 Years for all users including Commercial |
| SB | Cast Iron Auger Gear Case | 5 Years | Consumer | 5 Years for Consumer use; 1 Year for Commercial Use |
| SB | Batteries for AMP [™] Sno-Thro [®] | 2 Years | Consumer | 100% first year; prorated second year. |

Exceptions and Limitations

The chart below details special exceptions to this warranty:

| Warranty Code | Warranty Exception | Warranty Period | Use | Detail |
|----------------------|--|------------------------------------|------------|---|
| All | Batteries | 1 Year | All | Prorated |
| All | Belts, Muffler, Tires | None | Commercial | These components are not covered when used commercially. |
| All | Cloth, Plastic, and Rubber Components (Including Belts and Cables) | Maximum 2 Years | All | Warranty is limited to 2 years for consumer use. (1 year for warranty code "PD".) Except as noted above, these components are covered for defect, not for wear. |
| SA, SB, SC | Idlers | Maximum 2 Years | All | Warranty is limited on idlers to 2 years for consumer use. |
| All | Engines | See Engine Manufacturer's Warranty | All | Engines are covered by engine manufacturer's warranty. Refer to engine manufacturer's warranty statement. |

Customer Responsibilities

Register the product immediately at the time of sale. If the dealer does not register the product, the customer must complete the product registration card in the literature package and return it to the Ariens Company, or register the unit online at www.ariens.com, www.gravely.com, www.countax.com, www.parkersweeper.com.

To obtain warranty service, the **original purchaser** must:

- Perform the maintenance and adjustments explained in the owner's manual.
- Promptly notify Ariens or an authorized Ariens, Gravely, Parker or Countax service representative of the need for warranty service.
- Transport the product to and from the place of warranty service at owner's expense.
- Have the warranty service performed by an authorized Ariens, Gravely, Parker or Countax service representative.

To Find an Authorized Service Representative:

| | | |
|---|---|---|
| In the U.S. and Canada: | | |
| Use the dealer locator on our websites: www.ariens.com • www.gravely.com | | |
| Or contact us by mail or by phone: | | |
| In the U.S., Canada, Mexico, Caribbean, Central and South America: | In Europe, Asia, Africa or the Middle East: | In Australia or New Zealand: |
| Ariens Company 655 W. Ryan Street Brillion, WI 54110 Phone: (920) 756 - 4688 www.ariens.com | Countax Ltd, Countax House Great Haseley, Oxfordshire, OX44 7PF Phone: 0800 597 7777 www.countax.com | Ariens Company Building 2 6 Wedgewood Rd. Hallam, Victoria 3803 Australia Phone: (03) 9796 4244 1800 335 489 www.ariens.com.au |

Exclusions – Items Not Covered by This Warranty

- Parts that are not genuine Ariens, Gravely, Parker or Countax service parts are not covered by this warranty and may void the warranty.
- Damages resulting from the installation or use of any part, accessory, or attachment which is not approved by the Ariens Company for use with product(s) identified herein are not covered by this warranty.
- The following maintenance, service and replacement items are not covered by this warranty unless they are noted in the Limitations section above: lubricants, spark plugs, oil, oil filters, air filters, fuel filters, brake linings, brake arms, brake shoes, skid shoes, scraper blades, shear bolts, mower blades, mower vanes, brushes, headlights, light bulbs, knives, cutters.
- Any misuse, alteration, improper assembly, improper adjustment, neglect, or accident which requires repair is not covered by this warranty.
- **Use of gasoline blends exceeding 10% ethanol voids any and all warranties.**
- Products are designed to the specifications in the area that the product was originally distributed. Different areas may have significantly different legal and design requirements. This warranty is limited to the requirements in the area in which the unit was originally distributed. Ariens Company does not warrant this product to the requirements of any other area. Warranty service is limited to service within the area originally distributed.
- In countries other than the United States and Canada, contact the Ariens Company dealer for warranty policies that govern within your country. Rights may vary from country to country and within any one country.
- Normal Wear: This warranty does not cover repair when normal use has exhausted the useful life of a part such as a high pressure hose, spray wand, nozzles, trigger handle, supply hoses, quick couplers, gaskets, valves, pistons, pump valve assemblies, o-rings, water and oil seals.

Special Exclusions on Utility Vehicles

The following uses void the warranty terms on Utility Vehicles (Warranty Code UA):

- Renting or leasing the utility vehicle.
- Using the utility vehicle to tow or carry loads in excess of the limits specified in the owner/operator manual.
- Modifying the utility vehicle with parts and accessories that are not genuine or authorized Ariens or Gravely parts or accessories.
- Modifying the utility vehicle without express written authorization from the Ariens Company.
- Operating the utility vehicle when it has not been completely and properly assembled and pre-delivered by an authorized Gravely dealer.

Disclaimer

Ariens Company may from time to time change the design of its products. Nothing contained in this warranty shall be construed as obligating the Ariens Company to incorporate such design changes into previously manufactured products, nor shall such changes be construed as an admission that previous designs were defective.

LIMITATION OF REMEDY AND DAMAGES

Ariens Company's liability under this warranty, and under any implied warranty that may exist, is limited to repair of any defect in workmanship, and repair or replacement of any defective part. Ariens Company shall not be liable for incidental, special, or consequential damages (including lost profits). Some states do not allow the exclusion of incidental or consequential damages, so the above limitation or exclusion may not apply to you.

AUSTRALIAN CONSUMER LAW

The following applies solely to warranties subject to Subsection 102(1) of the Australian Consumer Law: Our goods come with guarantees that cannot be excluded by the Australian Consumer Law. You are entitled to a replacement or refund for a major failure and for compensation for any other reasonably foreseeable loss or damage. You are also entitled to have the goods repaired or replaced if the goods fail to be of acceptable quality and failure does not amount to a major failure.

DISCLAIMER OF FURTHER WARRANTY

Ariens Company makes no warranty, express or implied, other than what is expressly made in this warranty. If the law of your state provides that an implied warranty of merchantability, or an implied warranty of fitness for particular purpose, or any other implied warranty, applies to Ariens Company, then any such implied warranty is limited to the duration of this warranty. Some states do not allow limitations on how long an implied warranty lasts, so the above limitation may not apply to you.

This warranty gives you specific legal rights, and you may also have other rights which vary from region to region.

CALIFORNIA AND EPA (UNITED STATES ENVIRONMENTAL PROTECTION AGENCY) EVAPORATIVE EMISSION CONTROL WARRANTY STATEMENT

YOUR WARRANTY RIGHTS AND OBLIGATIONS

The CARB (California Air Resources Board), the EPA, and Ariens Company are pleased to explain the evaporative emission control system's warranty on your 2012 model year small off-road equipment. In California, new equipment that uses small off-road engines must be designed, built, and equipped to meet the State's stringent anti-smog standards. Ariens Company must warrant the evaporative emission control system on your small off-road equipment for the period listed below provided there has been no abuse, neglect or improper maintenance of your equipment.

Your evaporative emission control system may include parts such as: fuel tanks, fuel lines, fuel caps, valves, canisters, filters, vapor hoses, clamps, connectors, and other associated components.

MANUFACTURER'S WARRANTY COVERAGE:

This evaporative emission control system is warranted for two years. If any evaporative emission-related part on your equipment is defective, the part will be repaired or replaced by Ariens Company.

OWNER'S WARRANTY RESPONSIBILITIES:

- As the small off-road equipment owner, you are responsible for the performance of the required maintenance listed in your Owner's Manual. Ariens Company recommends that you retain all receipts covering maintenance on your small off-road equipment, but Ariens Company cannot deny warranty solely for the lack of receipts.
- As the small off-road equipment owner, you should however be aware that the Ariens Company may deny you warranty coverage if your evaporative emission control system part has failed due to abuse, neglect, or improper maintenance or unapproved modifications.
- You are responsible for presenting your small off-road equipment to an authorized Ariens, Gravelly, or Parker service representative as soon as the problem exists. The warranty repairs should be completed in a reasonable amount of time, not to exceed 30 days. If you have a question regarding your warranty coverage, you should contact Ariens Company Technical Service Center at 1-920-756-2141.

DEFECTS WARRANTY REQUIREMENTS:

- (a.) The warranty period begins on the date the small off-road equipment is delivered to an ultimate purchaser.
- (b.) General Evaporative Emissions Warranty Coverage. Ariens Company warrants to the ultimate purchaser and any subsequent owner that the evaporative emission control system when installed was:
 - (1.) Designed, built, and equipped so as to conform with all applicable EPA and CARB regulations; and
 - (2.) Free from defects in materials and workmanship that causes the failure of a warranted part for a period of two years.
- (c.) The warranty on evaporative emissions-related parts will be interpreted as follows:
 - (1.) Any warranted part that is not scheduled for replacement as required maintenance in the written instructions must be warranted for the warranty period defined in subsection (b)(2). If any such part fails during the period of warranty coverage, it must be repaired or replaced by the Ariens Company. Any such part repaired or replaced under the warranty must be warranted for a time not less than the remaining warranty period.
 - (2.) Any warranted part that is scheduled only for regular inspection in the written instructions must be warranted for the warranty period defined in subsection (b)(2). A statement in such written instructions to the effect of "repair or replace as necessary" will not reduce the period of warranty coverage. Any such part repaired or replaced under warranty must be warranted for a time not less than the remaining warranty period.

- (3.) Any warranted part that is scheduled for replacement as required maintenance in the written instructions must be warranted for the period of time prior to the first scheduled replacement point for that part. If the part fails prior to the first scheduled replacement, the part must be repaired or replaced by the Ariens Company. Any such part repaired or replaced under warranty must be warranted for a time not less than the remainder of the period prior to the first scheduled replacement point for the part.
- (4.) Repair or replacement of any warranted part under the warranty provisions of this article must be performed at no charge to the owner at an authorized Ariens, Gravelly, or Parker service representative.
- (5.) Notwithstanding the provisions of subsection (4) above, warranty services or repairs must be provided at authorized Ariens, Gravelly, or Parker service representatives that are franchised to service the subject small off-road equipment.
- (6.) The owner must not be charged for diagnostic labor that leads to the determination that a warranted part is in fact defective, provided that such diagnostic work is performed at an authorized Ariens, Gravelly, or Parker service representative.
- (7.) Throughout the evaporative emission control system's warranty period set out in subsection (b)(2), the Ariens Company must maintain a supply of warranted parts sufficient to meet the expected demand for such parts.
- (8.) Manufacturer-approved replacement parts must be used in the performance of any warranty maintenance or repairs and must be provided without charge to the owner. Such use will not reduce the warranty obligations of the manufacturer issuing the warranty.
- (9.) The use of any add-on or modified parts will be grounds for disallowing a warranty claim made in accordance with this article. The manufacturer issuing the warranty will not be liable under this Article to warrant failures of warranted parts caused by the use of an add-on or modified part.

EVAPORATIVE EMISSION WARRANTY PARTS LIST

The following parts are considered emission-related components for evaporative emissions:

- Fuel Tank, Fuel Cap and Tether
- Fuel Line, Fuel Line Fittings, Clamps*
- Pressure Relief Valves, Control Valves*
- Control Solenoids*, Electronic Controls*
- Vacuum Control Diaphragms*
- Control Cables*, Control Linkages*
- Purge Valves
- Vapor Hoses, Liquid/Vapor Separator
- Carbon Canister, Canister Mounting Brackets
- Carburetor Purge Port Connector

* As related to the evaporative emission control system

DISCLAIMER

New equipment sold in the state of California that uses small off-road engines must be exclusively certified and appropriately labeled for sale in California. Some equipment covered by this Owner's Manual may not be certified for sale in California and the presence of the preceding CARB and EPA Warranty Statement does not by its existence indicate which, if any, of the equipment covered by this Owner's Manual may be sold in California.

Some equipment covered by this Owner's Manual may have been manufactured prior to certain affectivity dates requiring the inclusion of evaporative emission control systems. Therefore some equipment covered by this Owner's Manual may not include the evaporative emission control systems referred to in the preceding CARB and EPA Warranty Statement.

Sno-Tek™

By Ariens

Ariens Company
655 West Ryan Street
Brillion, WI 54110

920-756-4688
www.ariens.com

Sno-Tek Cover

Waterproof, washable and tear-resistant, this cover protects your Sno-Tek when it is not in use.



Non-Abrasive Skid Shoes

Protect the decorative surfaces around your home.

Sno-Tek LCT® Engine Maintenance Kit

Includes Ariens 32oz. 5W30 engine oil, Spark Plug, Fuel stabilizer and a spare ignition key.



Drift Cutter

Extend the bars to cut through drifts and direct snow into the auger.

*2010 Ariens Company ® Registered Trademark and ™ Trademark of Ariens Company. LCT is a registered trademark of Liquid Combustion Tech LLC. Features and specifications are subject to change without notice.

⚠ WARNING ⚠

The engine exhaust from this product contains chemicals known to the State of California to cause cancer, birth defects or other reproductive harm.

An *Ariens* Company Brand