

SAFETY. COMFORT.
BEAUTY. VALUE.

There is no sacrifice with American Standard Walk-In Baths. Deep and spacious, all of our walk-in baths are thoughtfully designed to provide accessible and comfortable bathing experiences. You can trust American Standard to provide innovative features along with the quality, reliability and service you have come to expect with our 140 year heritage.

MODEL 3260.210

- Premium cast acrylic construction
- 32" wide x 60" long x 37"
- Operating capacity: 80 gallons
- Color: white or linen
- Left hand or right hand door & drain

BUILT-IN FEATURES

- Large, watertight door system
- Built-in chair height seat
- Color matched safety bar
- Color matched cable driven drain
- Textured tub floor
- Pump and fixture access panels
- Free standing metal support frame
- Lifetime warranty on door seal; 10 years on the tub shell; 5 years on components

OPTIONS

- Patented Quick Drain® fast water removal technology
- Whirlpool heater
- Chromatherapy
- Neck rest
- Universal wall surround
- 24" chrome grab bar
- Extension kit to fit into 60" space



Whirlpool

Enjoy therapeutic benefits of deep massage



Air Spa

A gentle effervescent experience



Combination

Combines both Air Spa and Whirlpool systems for a full in-home spa experience



Quick Drain® Optional

Our exclusive Quick Drain® technology empties tub in less than two minutes and requires no additional plumbing. Spend less time waiting with this patented innovation.

www.americanstandard-us.com/safe-and-accessible

Walk-In Bath

3260.210 Series



American Standard

STANDARD SERIES

32" x 60" WALK-IN BATH SOAKING TUB, AIR SPA & WHIRLPOOL

3260.210.SXX Soaking Tub

- Premium cast acrylic construction
- Free standing metal support frame with five adjustable leveling feet
- Easy access, watertight door system
- Contoured, built-in seat
- Built-in safety bar and textured tub floor
- Faucet/accessory deck areas
- Color matched cable driven drain assembly

3260.210.WXX Whirlpool System

- Easy touch push button control
- 7 amp pump
- 13 variable flow massage jets
- Legs-only massage
- Self-cleaning sanitation system

3260.210.AXX Air Spa System

- Easy touch push button control
- 3 speed heated blower
- 26 seat and floor air injectors
- Automatic purge cycle

3260.210.CXX Combination System

- Combines Whirlpool and Air Spa System

Nominal Dimensions:

32" x 60" x 37"
(813 x 1524 x 940mm)

Compliance Certifications -

Meets or Exceeds the Following Specifications:

- ETL - INTERTEK SEMKO
- IAPMO - USPC
- ANSI Z 124.1.2 - for Plastic Bathtubs
- ASME A112.19.7 - Whirlpool Appliances
- ASME A112.19.15 - for Walk-In Bathtubs
- CSA B-45.5 - Canadian Plumbing Fixtures

To Be Specified - Required:

- Drain Configuration: Left (L) or Right (R)
- Color: White (W) or Linen (L)
- Faucet: 9FHS
- Chromatherapy: 9CTP
- Neck Rest: 9NR
- Handshower Glide Bar: 9HSB
- 24 inch Grab Bar: 9GB-24

* **Note:** The whirlpool heater is designed to maintain water temperature during operation. It will not heat cold water to desired bathing temperature.

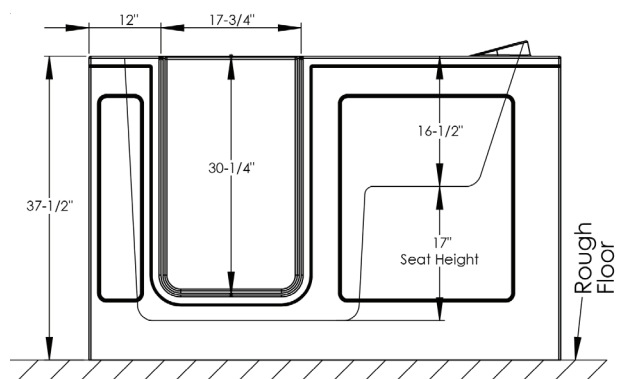
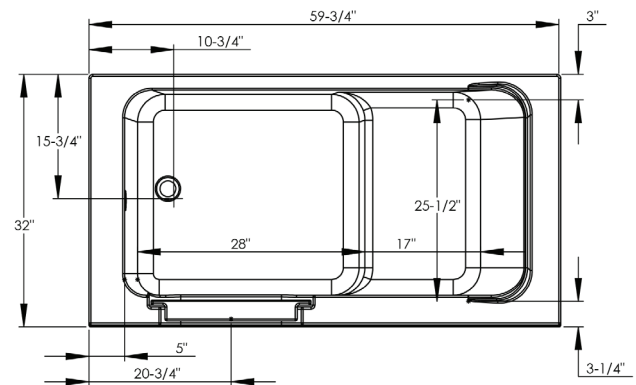

GENERAL SPECIFICATIONS FOR 3260.210 WALK-IN BATHING TUB

INSTALLED SIZE	_____	60x32x37In. (1524x813x940mm)
WEIGHT	_____	234Lbs. (106Kg.)
WEIGHT w/WATER	_____	900Lbs. (408Kg.)
OPERATING GALLON	_____	80Gal. (303L.)
FLOORLOADING	_____	58Lbs./Sq.Ft. (283Kgs/Sq.m.)
(PROJECTED AREA)	_____	
CUBE (FT ³)	_____	41.1

Notes:

TUB IS SUPPORTED BY THE FRAME AND FIVE INTEGRATED ADJUSTABLE FEET, NO ADDITIONAL SUPPORT REQUIRED.

REFER TO INSTALLATION INSTRUCTIONS SUPPLIED WITH TUB FOR ADDITIONAL INFORMATION.

FAUCETS NOT INCLUDED AND MUST BE ORDERED SEPARATELY.

PROVIDE SUITABLE REINFORCEMENT TO SUB FLOOR FOR ALL SUPPORTS.

IMPORTANT: Dimensions of fixtures are nominal, may vary and are subject to change or cancellation. No responsibility is assumed for use of superseded or voided leaflet.