

SERIN™ Wall Mount Electronic Proximity Lavatory Faucet

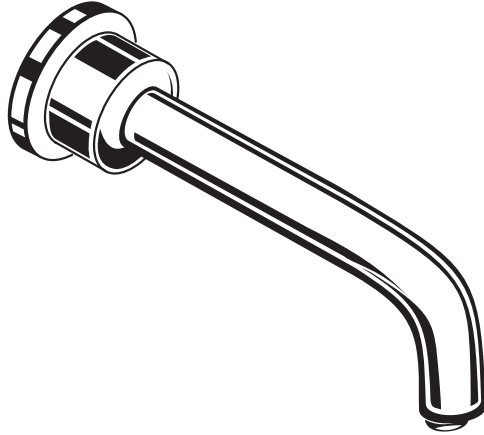

NOTE: Please refer to R350 Mounting Kit installation instructions #M965614 prior to faucet installation.

Certified to comply with ASME A112.18.1
© 2015 American Standard

MODEL NUMBERS

T064.342	T064.345	T064.346
T064.353	T064.355	T064.356
T064.362	T064.365	T064.366
T064.372	T064.375	T064.376
T064.392	T064.395	T064.396

CAUTION: Use only American Standard supplied transformers and cable sets. Using non-AS supplied cables, or cutting, splicing or modifying any components will void the warranty.

Product No.'s & Options	1
Specifications	2
Faucet Installation	2-5
Electrical Installation	6-8
Start-up / Maintenance	9-10
FAQ's / Troubleshooting	10-11
Replacement Parts	12

American Standard

NOTE TO INSTALLER: Please give this manual to the customer after installation.

To learn more about American Standard Selectronic® Products visit our website at: www.americanstandard-us.com or e-mail us at: CRTTEAM@americanstandard.com

For Parts, Service, Warranty or other Assistance,
please call (844) CRT-TEAM / (844) 278-8326 (In Canada: 1-800-387-0369)
(In Toronto Area only: 1-905-306-1093)



Thank you for selecting American-Standard...the benchmark of fine quality for over 100 years. To ensure that your installation proceeds smoothly--please read these instructions carefully before you begin.

UNPACKING

All American Standard Faucets Are Water Tested At Our Factory. Some Residual Water May Remain In The Faucet During Shipping.

1. Remove the fitting and loose items from the carton. The illustration below shows the fitting and all loose items after they have been removed from the carton. Some items may be packaged partially assembled to other items.

- | | |
|--|---|
| 1. Installation Instructions | 7b. DC Standard Battery (for .353, .355, .356) |
| 2. Spout Assembly | 7c. AC Power Supply (for .362, .365, .366) |
| 3. Elbow Kit | 7d. AC Power Transformer (.392, .395, .396) |
| 4. Mounting Kit | 8. Y-Adapter |
| 5. Supply Hose | 9. 10 ft. Extension |
| 6. Control box | 10. Mixing Valve (optional, must be ordered separately) |
| 7a. DC Long Life Power Pack (for .342, .345, .346) | 11. Control Box Cover Screws |

<p>How to order the Serin™ Proximity Product</p> <p>1. Choose Power Supply</p> <p>2. Choose Desired Flow Rate</p> <p>+</p> <p>The R350 Mounting Kit is a required component that must be purchased separately.</p>	<p>Spout</p>	<p>DC Long Life Power Pack T064.342 T064.345 T064.346</p>	<p>DC Standard Battery T064.353 T064.355 T064.356</p>	<p>AC Plug-in T064.362 T064.365 T064.366</p>	<p>AC Hardwire T064.392 T064.395 T064.396</p>	<p>AC Multi T064.372 T064.375 T064.376</p>	
	<p>Base Product</p>						
<p>Mixing Valve</p> <p>605XTMV1070</p>	<p>Mixing Valve</p>	<p>R350 MOUNTING KIT (Must have R350 Mounting Kit installed prior to Wall Mount faucet installation)</p>					<p>Mixing Valve (optional) • Hot and Cold Inlets</p>

Roughing-in Dimensions

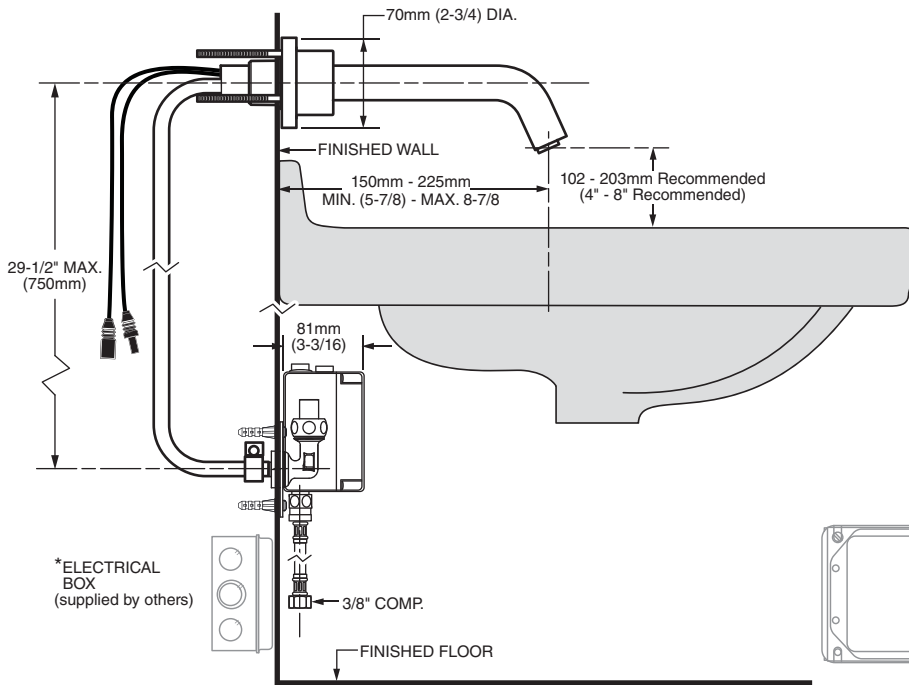

GENERAL DESCRIPTION:

Electronic faucet with proximity operation. Vandal resistant solid brass construction single post mounting. Operates on DC (battery/power pack) or AC permanent power (plug-in/hardwire). In-line strainer for solenoid is integral. Single inlet 3/8 compression, built-in checks, and flexible stainless steel 16-1/4" reach inlet hose for spout connection.

Note: All plumbing and electrical wiring must be installed in accordance with applicable codes, regulations and standards.

CAUTION: Use only American Standard supplied transformers and cable sets. Using non-AS supplied cables, or cutting, splicing or modifying any components will void the warranty.

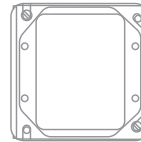

*RECOMMENDED CONTROL BOX OR EQUIVALENT BY OTHERS
CONTROL BOX IS ONLY REQUIRED FOR HARD-WIRED AC INSTALLATIONS (.392 & .395)
4" (102mm) SQ. X 3-1/2" (89mm) DEEP CONTROL BOX
Hubbel-RACO #256 OR EQUAL (BY CONTRACTOR).

RECOMMENDED TOOLS

- | | |
|-------------------------------|-----------------------------------|
| 1 Slip Jaw Pliers | 5 Flat Blade Screwdriver |
| 2 Adjustable Wrench | 6 Electric Drill & 1/4" Drill Bit |
| 3 Plumbers' Putty or Caulking | 7 Tape Measure |
| 4 Phillips Screwdriver | |

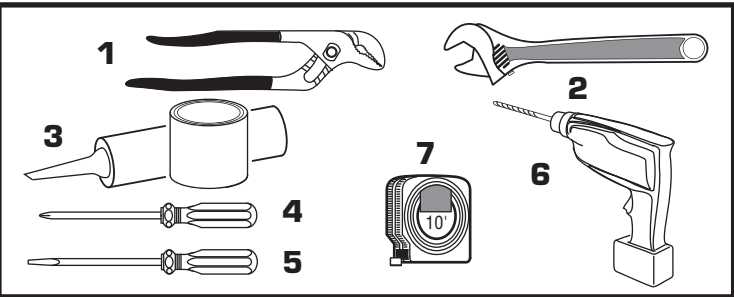

FAUCET INSTALLATION

1 SPOUT ASSEMBLY INSTALLATION; Fig. 1

CAUTION Turn off hot and cold water supplies before beginning

- Remove both MOUNTING SCREWS (1), then remove upper PLASTIC GUARD (2). Remove the CORD HOLDER (3a) and CABLE HOLDER (4a) from the PLASTER GUARD (2). **IMPORTANT: Secure the CORD HOLDER (3a) and the CABLE HOLDER (4a) from falling back through the hole in the wall.**
- Remove the two EXTENSION CABLE ENDS (5a) from the CABLE HOLDER (4a). **IMPORTANT: Secure the CORD HOLDER (3a) and the EXTENSION CABLES (5a) from falling back through the hole in the wall.**
- Remove the CORD HOLDER (3b) and CABLE HOLDER (4b) from the two bottom PLASTER GUARDS (6). Use a flat blade screwdriver to break off the two ends of the lower PLASTER GUARDS (6) flush with the finished wall. **IMPORTANT: Be carefull not to damage the wire cables. Secure the CORD HOLDER (3b) and the CABLE HOLDER (4b) from falling back through the holes in the wall.** Remove the two EXTENSION CABLE ENDS (5b) from the CABLE HOLDER (4b).

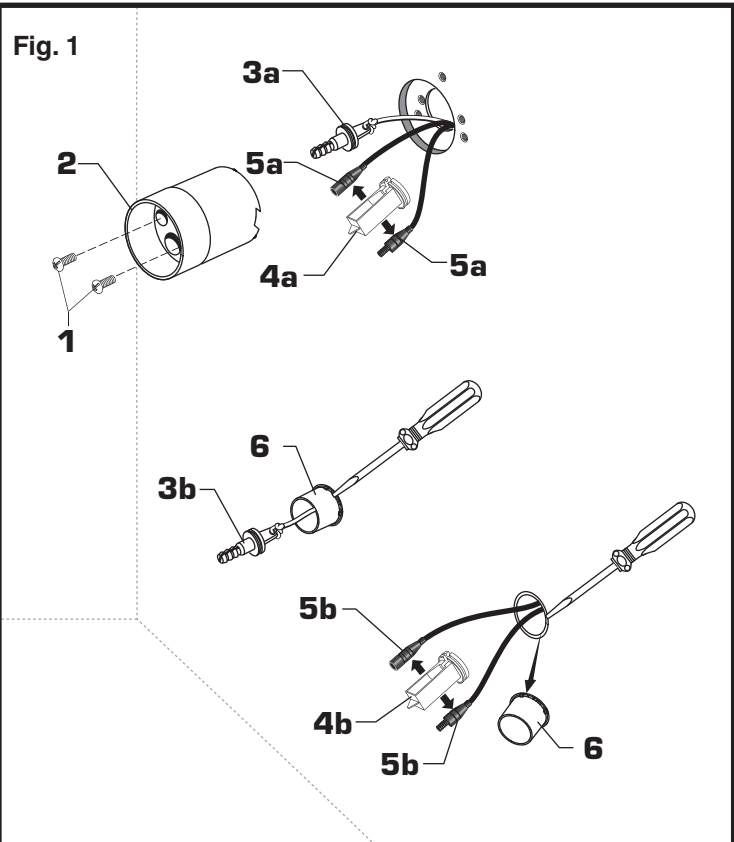

1a INSTALL SPOUT MOUNTING KIT; Fig. 2

1. Make sure that SEAL (7) is installed into the groove on the back of the MOUNTING FLANGE (8). Feed the CORD HOLDER (3a) and the EXTENSION CABLES (5a) through the MOUNTING FLANGE (8).
2. Install the MOUNTING FLANGE (8) to the wall with three SCREWS (9) that thread into the MOUNTING PLATE (10) within the wall. **DO NOT fully tighten the SCREWS (9). HAND TIGHTEN ONLY.**

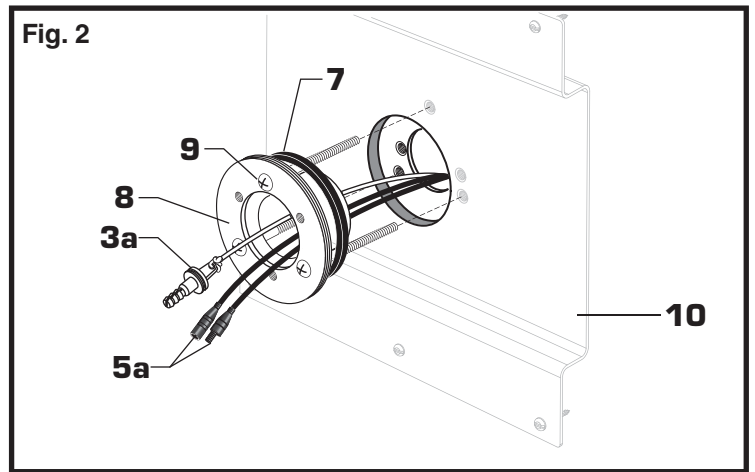

1b INSTALL SPOUT ASSEMBLY; Fig. 3

1. Slide SPOUT ESCUTCHEON (11) onto SPOUT (12).
2. Slide COMPRESSION RING (13) and COMPRESSION SEAL (14) onto SPOUT (12).
3. Connect SPOUT HOSE (15) onto CORD HOLDER (3a) by pressing until secure connection is achieved.

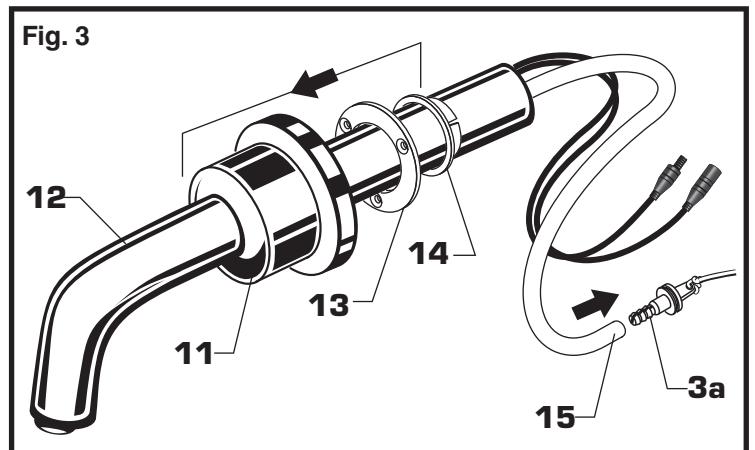

1c SECURE WIRE CONNECTIONS; Fig. 4

1. Connect the FAUCET SENSOR CONNECTORS (16) to the EXTENSION CABLES (5a), and secure the connections by installing into CONNECTOR HOUSINGS (17) as shown. Rotate the END CAPS (18) to secure the connection within the CONNECTOR HOUSINGS (17).
2. Pull the bottom end of EXTENSION CABLES (5b) so that the CONNECTOR HOUSINGS (17) are inside the wall.
4. Pull bottom CORD HOLDER (3b) and fish SPOUT HOSE (15) through the wall and out through the bottom wall opening (19).
5. Cut the CORD HOLDER (3a) off the end of the SPOUT HOSE (15) as shown. **IMPORTANT: Secure the SPOUT HOSE (15) from falling back through the wall opening (19).**

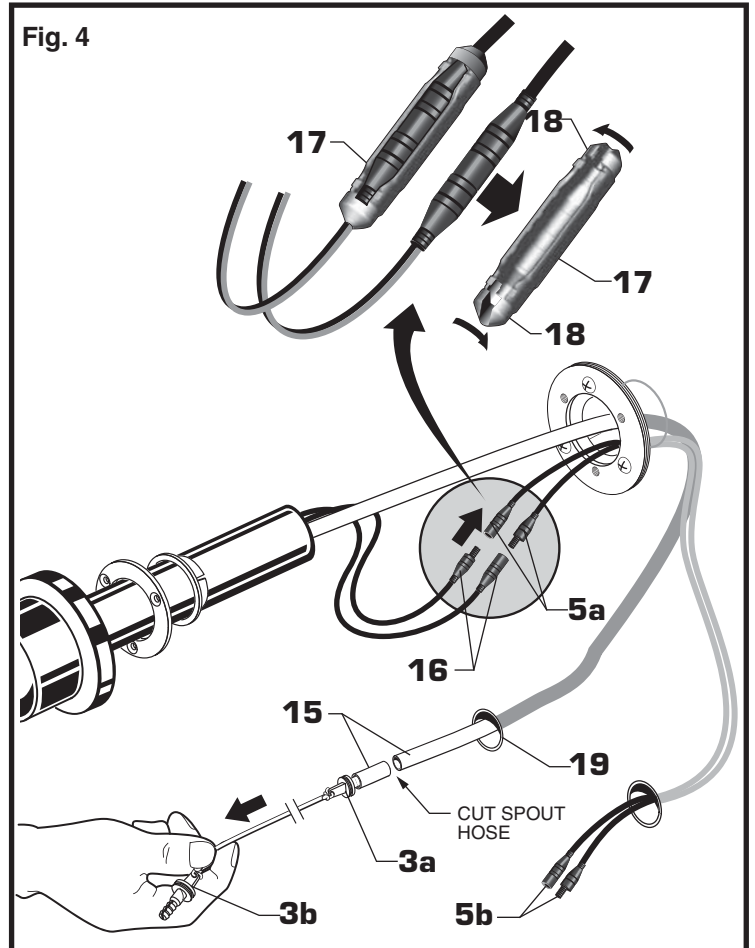

1d ALIGN SPOUT ASSEMBLY; Fig. 5

1. Align and push SPOUT (12) through hole, loosely installed MOUNTING FLANGE (8) and MOUNTING PLATE (10).
2. Once MOUNTING FLANGE (8) is aligned with MOUNTING PLATE (10) opening, tighten the three MOUNTING FLANGE SCREWS (9). (*Tighten each screw little by little to avoid misalignment!*)
3. Align and slide COMPRESSION SEAL (14) and COMPRESSION RING (13) to MOUNTING FLANGE (8).

1e SECURE SPOUT ASSEMBLY; Fig. 6

1. Once MOUNTING FLANGE (8) is installed, move the SPOUT (12) in or out to determine desired spout length from finished wall. **Note: The Min. is 150mm, (5-7/8) and the Max. is 225mm, (8-7/8) from the finished wall to center of the spout end.**
2. Tighten COMPRESSION RING (13) to MOUNTING FLANGE (8) by tightening the three COMPRESSION RING SCREWS (20) with HEX WRENCH (21) supplied. This will fix SPOUT (12) length from finished wall.
3. Push ESCUTCHEON (11) to MOUNTING FLANGE (8) and hand tighten to complete spout installation.

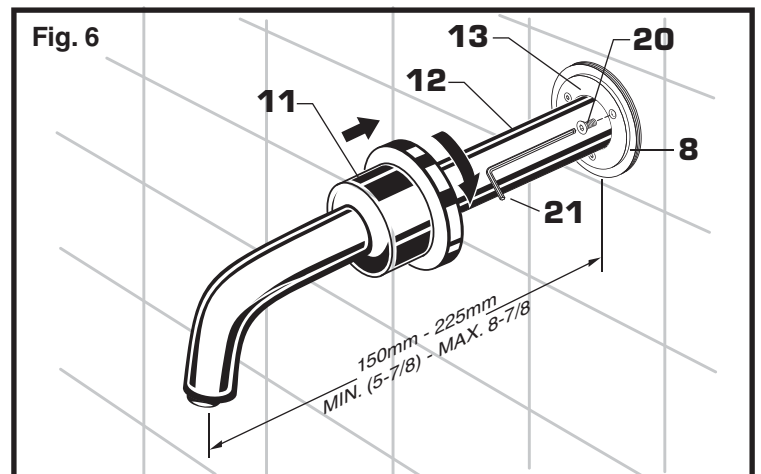
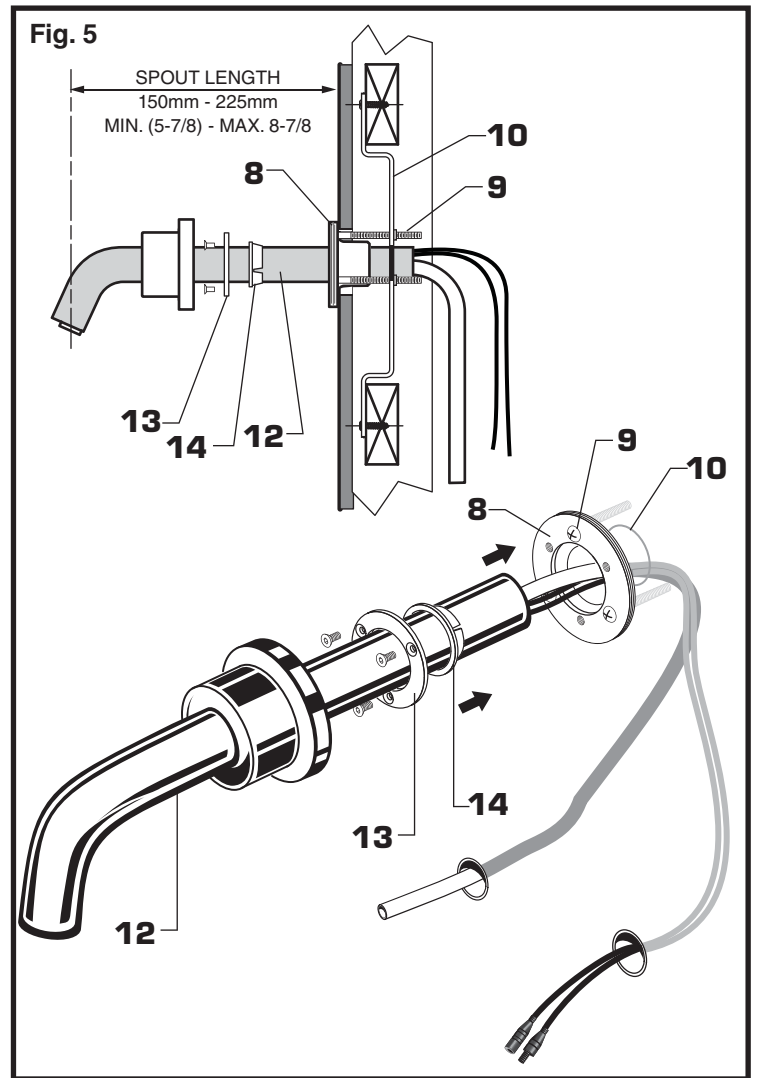

2 INSTALL SUPPLY ELBOW ASSEMBLY & CONTROL BOX; Fig. 7 and Fig. 7a

1. Install HOSE CLAMP (22) onto SPOUT HOSE (15). Install SPOUT HOSE (15) onto ELBOW NIPPLE (23). Fully tighten HOSE CLAMP (22) to secure SPOUT HOSE (15) to ELBOW ASSEMBLY (24). Fig. 7.
2. Using the ANCHORS (25) and SCREWS (26) supplied, attach ELBOW ASSEMBLY (24) to finished wall, covering the hole in wall. Fig. 7.
3. Remove CONTROL BOX COVER (27). Feed EXTENSION CABLES (5b) THROUGH GROMMET (28) in back of CONTROL BOX (29). (Refer to VIEW "A"). Hold the CONTROL BOX (29) so that it covers the wall opening and mark the four mounting hole locations as shown. Fig. 7a.
4. It is recommended that the CONTROL BOX (29) be secured to a wall stud or cross brace within the wall using the SCREWS (30) supplied. If the CONTROL BOX (29) is to be installed on tile or plaster walls, the ANCHORS (31) and SCREWS (30) should be used.

NOTE: Find plastic bag containing 4 M5X16 screws to be used for securing the CONTROL BOX COVER (1) when installation is complete.

3 CONNECT SPOUT HOSE TO CONTROL BOX; Fig. 8

1. Connect G 1/2" end of SUPPLY HOSE (32) to the ELBOW ASSEMBLY (24). Tighten with adjustable wrench to make a water tight connection.
2. Connect G 3/8" end of SUPPLY HOSE (32) to nipple on top of CONTROL BOX (29). Tighten with adjustable wrench to make a water tight connection.

3. IMPORTANT: INSERT FIBER WASHER (33) INTO SUPPLY NUT (34) ON CONTROL BOX (29).

4. Connect FLEXIBLE SUPPLY (35) to bottom SUPPLY NUT (34). Connect other end directly to wall supply. Connection is G 3/8" compression.

Note: FLEXIBLE SUPPLY (35) measures 20" from the bottom of the CONTROL BOX (29) base. If additional supply length is required, installer must purchase parts separately. If FLEXIBLE SUPPLY (35) is too long, loop to avoid kinking.

NOTE: If using Mixing Valve (optional) See Sheet #M968808 for installation instructions.

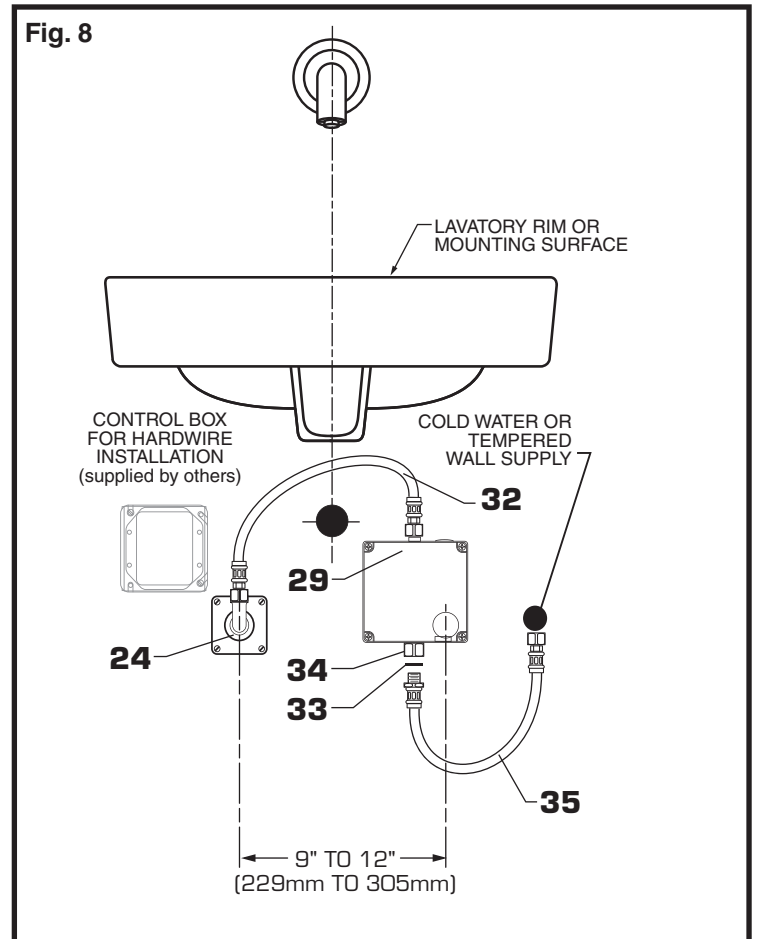
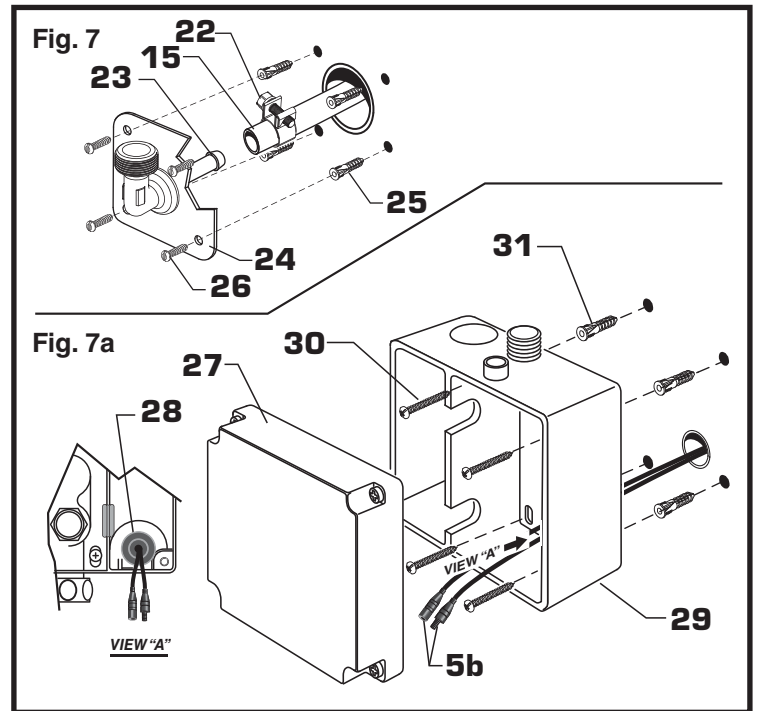

ELECTRICAL INSTALLATION

Product	Page
DC Long Life Power Pack T064.342 / T064.345	6
DC Standard Battery T064.353 / T064.355	6
AC Plug-in T064.362 / T064.365	7
AC Hardwire T064.392 / T064.395	7
AC Multi Hook-up T064.372 / T064.375	8

A LONG LIFE POWER PACK & STANDARD BATTERY; Fig. 1

1. Remove CONTROL BOX COVER (1) from CONTROL BOX (2). **Fig. 1.**
 2. Feed the EXTENSION CABLE (3) from the Faucet through SIDE GROMMET (4). **Fig. 1a.**
 3. Connect SOLENOID CABLE (5) to EXTENSION CABLE (3) from the Faucet. **Fig. 1a.**
 4. Insert BATTERY (6) into BATTERY HOLDER (7), make sure the shape of the BATTERY (6) follows the shape of the BATTERY HOLDER (7) and terminal end is inserted first. **Fig. 1b.**
- !** Prior to making power connection, make sure detection zone is not obstructed. Sensor is self adjusting. Keep detection zone clear for 15 seconds after power is connected.
5. Connect the BATTERY CONNECTOR (7a) from the Standard or Long Life Power Pack to EXTENSION CABLE (8) as shown. **Fig. 1c.** Place Standard Battery or Long Life Power Pack into Housing. **Fig. 1d.**
 6. Replace CONTROL BOX COVER (1). Tighten cover screws firmly.

CAUTION: Use only American Standard supplied transformers and cable sets. Using non-AS supplied cables, or cutting, splicing or modifying any components will void the warranty.

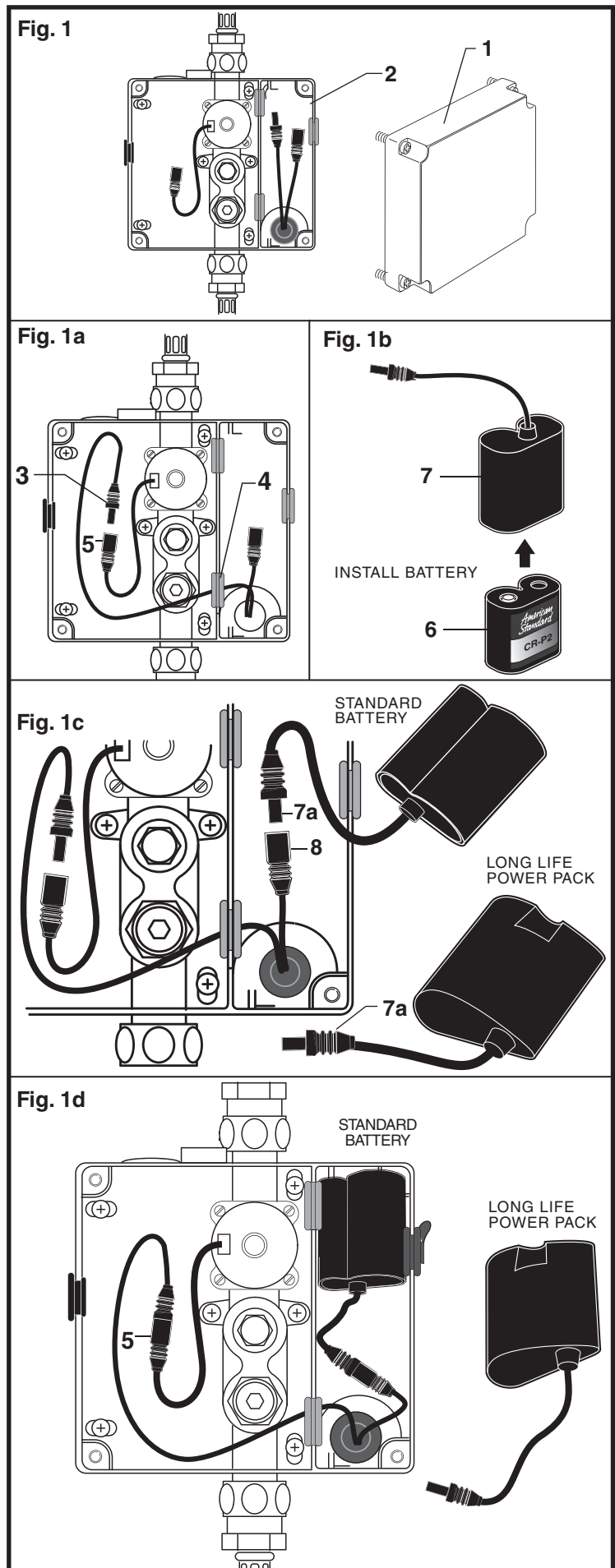

B AC VERSIONS (HARDWIRE / PLUG-IN); Fig. 2 and Fig. 3

CAUTION Before opening CONTROL BOX disconnect AC power supply.

1. Remove CONTROL BOX COVER (1) from CONTROL BOX (2). Fig. 2.
2. Feed the EXTENSION CABLE (3) from the faucet through GROMMET (4). Then connect the SOLENOID CABLE (5) to EXTENSION CABLE (3). Fig. 2a.

FOR PLUG-IN HOOKUP ONLY; Fig. 2

3. Insert POWER CORD (9) through OUTER GROMMET (10) as shown. Fig. 2a.
4. Connect POWER CORD (9) to EXTENSION CABLE (8) from faucet sensor. Replace CONTROL BOX COVER (1). Tighten cover screws firmly.

! Prior to making power connection, make sure detection zone is not obstructed. Sensor is self adjusting. Keep detection zone clear for 15 seconds after power is connected.

5. Plug AC POWER SUPPLY into wall outlet. Fig. 2a.

FOR HARDWIRE HOOKUP ONLY; Fig. 3

6. Insert 10 ft. EXTENSION (11a) from HARD WIRE POWER SUPPLY (12) into CONTROL BOX through OUTER GROMMET (10) and side GROMMET (4). Connect 10' Extension (11a) to single terminal of Y-ADAPTER (13). Fig. 3.
7. Insert EXTENSION CABLE (8) from faucet through GROMMET (4a) and connect to either of the two terminals at the one end of the Y-ADAPTER (13). Replace CONTROL BOX COVER (1). Tighten cover screws firmly. Fig. 3.

Contractor to supply ELECTRICAL BOX (14) and power to POWER SUPPLY (12). Fig. 3a.

8. Connect White and Black connections to POWER SUPPLY CONNECTIONS (15). Fig. 3a.

! Prior to making power connection, make sure detection zone is not obstructed. Sensor is self adjusting. Keep detection zone clear for 15 seconds after power is connected.

9. Connect the 10 ft. EXTENSION (11b) to the POWER SUPPLY CABLE (16). Mount POWER SUPPLY (12) into ELECTRICAL BOX (14).

CAUTION: Use only American Standard supplied transformers and cable sets. Using non-AS supplied cables, or cutting, splicing or modifying any components will void the warranty.

Fig. 2

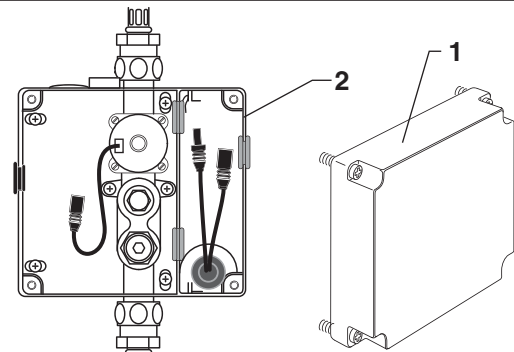

Fig. 2a

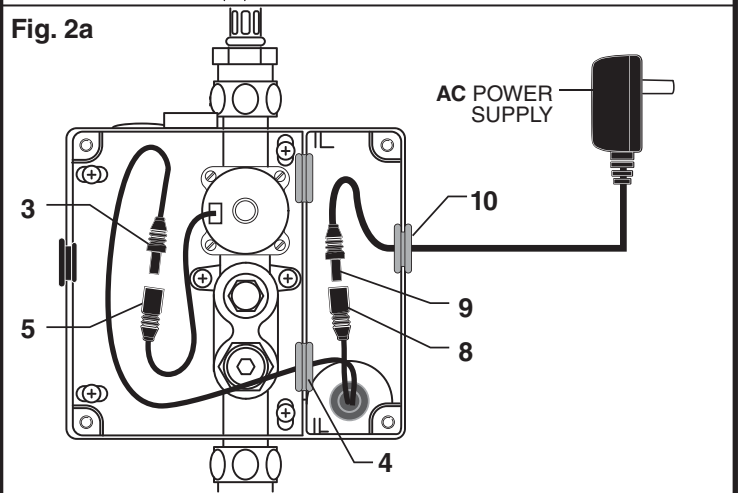

Fig. 3

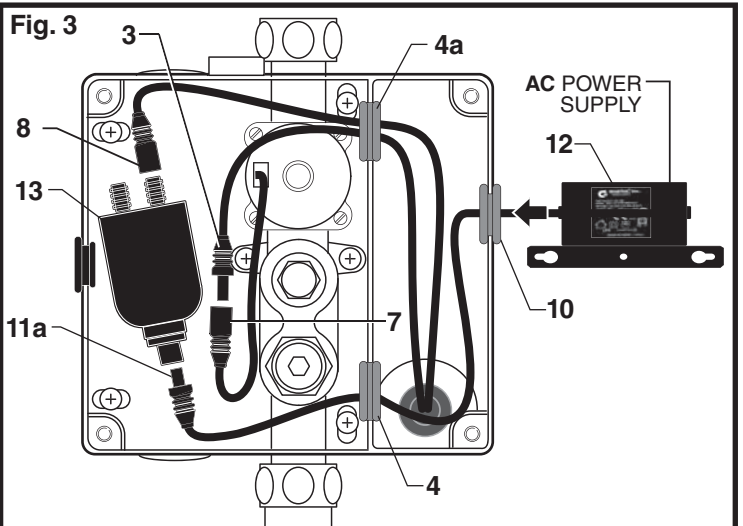
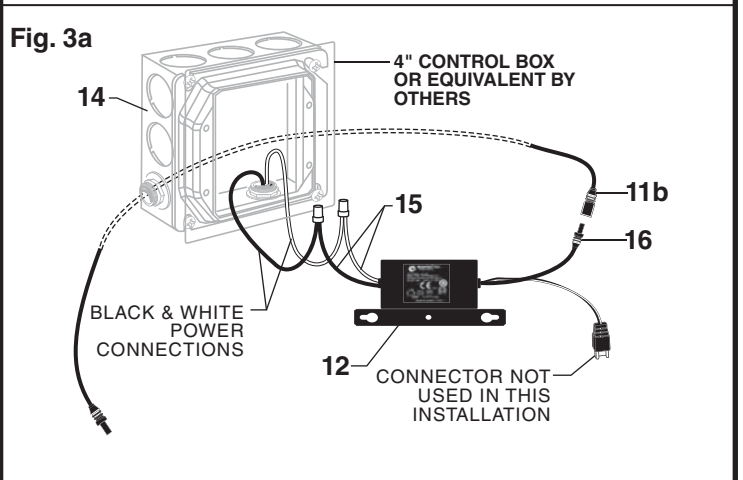
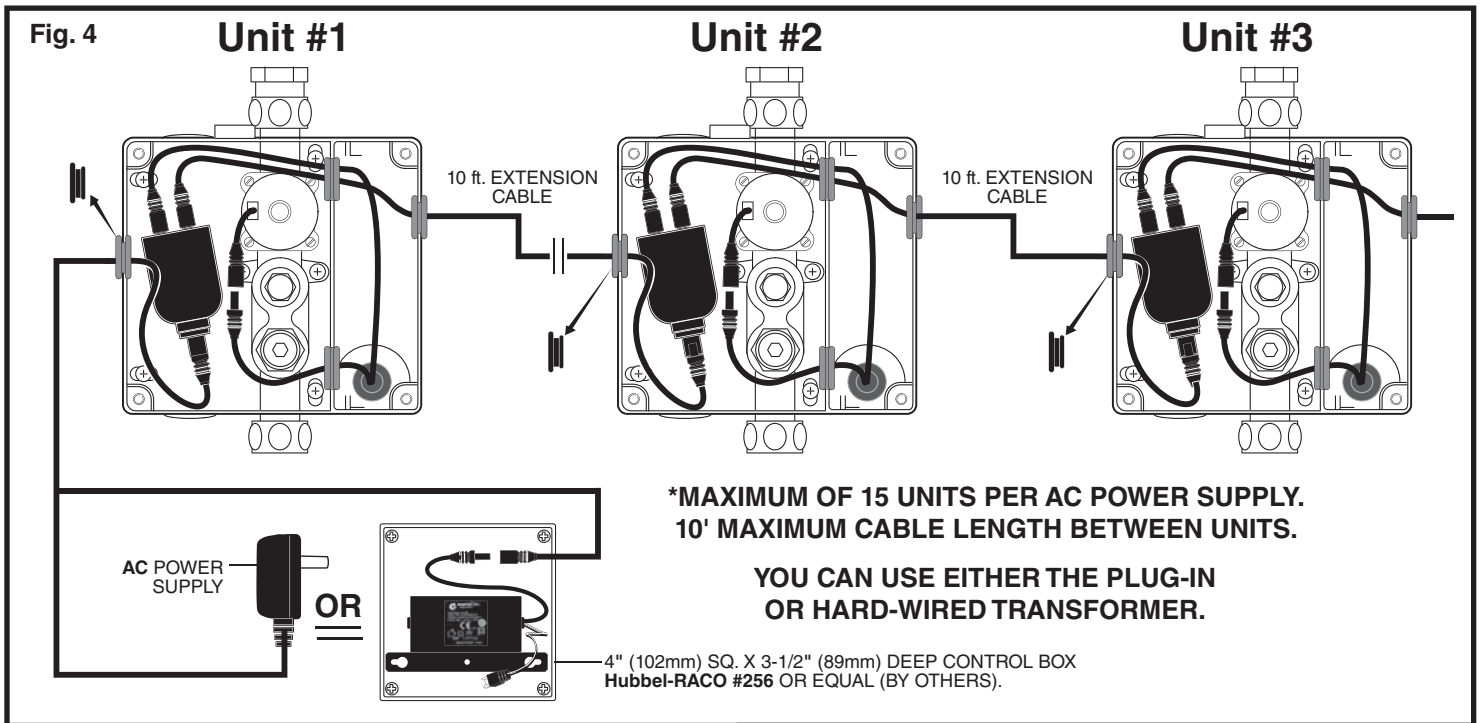

Fig. 3a





**FOR AC-VERSION
(MULTI HOOK-UP); Fig. 4 and Fig. 4a**

1. Remove COVERS from all CONTROL BOX (2).
Fig. 4 and Fig. 4a.
2. Remove SOLID BLACK PLUG GROMMET (17) from left side of all CONTROL BOX (2). Replace with GRAY GROMMET (18). (Supplied with each Faucet).
Fig. 4 and Fig. 4a.
3. Feed the EXTENSION CABLE (3) from the Faucet through GROMMET (4) and connect it to the SOLENOID CABLE (5). **Fig. 4 and Fig. 4a.**
4. Feed the EXTENSION CABLE (8) from the Faucet through GROMMET (4a) and connect to either of the two terminals at the one end of the Y-ADAPTER (13). Connect the 10 ft. EXTENSION (11a) to the other terminal at the same end of the Y-ADAPTER (13).
Fig. 4 and Fig. 4a.
5. Feed the other end of the 10 ft.EXTENSION (11b) through the two GRAY GROMMETS (4a and 4b) and connect to the single terminal end of the next unit's Y-ADAPTER (13). Place Y-ADAPTER (13) into CONTROL BOX (2) as shown in **Fig. 4 and Fig. 4a.**
6. Repeat Steps above for each additional Unit, for a **Max. of 15 Units** on one AC POWER SUPPLY.
7. Replace CONTROL BOX COVERS. Tighten cover screws firmly.

CAUTION: Use only American Standard supplied transformers and cable sets. Using non-AS supplied cables, or cutting, splicing or modifying any components will void the warranty.

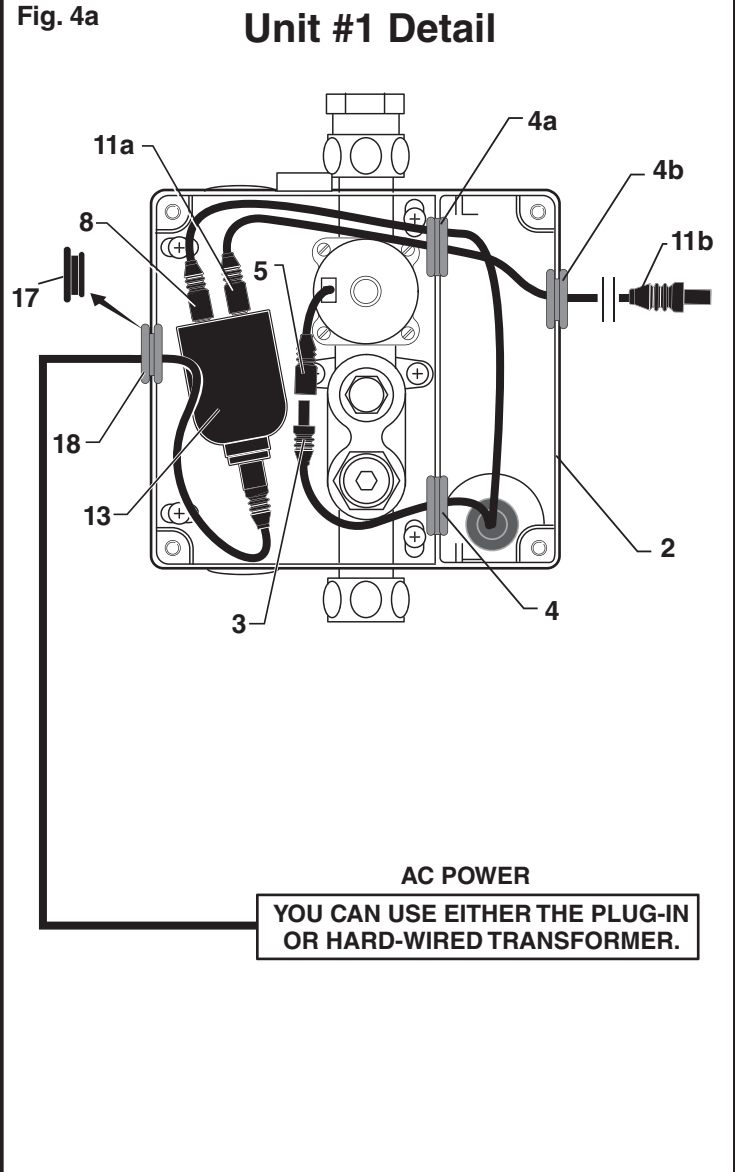

START-UP / MAINTENANCE

A HANDWASH SENSOR OPERATION; Fig. 1

! Prior to making power connection, make sure detection zone is not obstructed. Sensor is self adjusting. Keep detection zone clear for 15 seconds after power is connected.

When the Sensor detects a user, the water immediately starts to flow. Water flow will stop 1.5 seconds after user is out of sensor range. This comfort timer allows the user to move his hands without the flow cycling on and off. As a precaution, a safety timer will turn off the water after the sensor has been blocked for 55 seconds. Water flow will resume when the blockage is removed from the detection zone and the sensor is activated again.

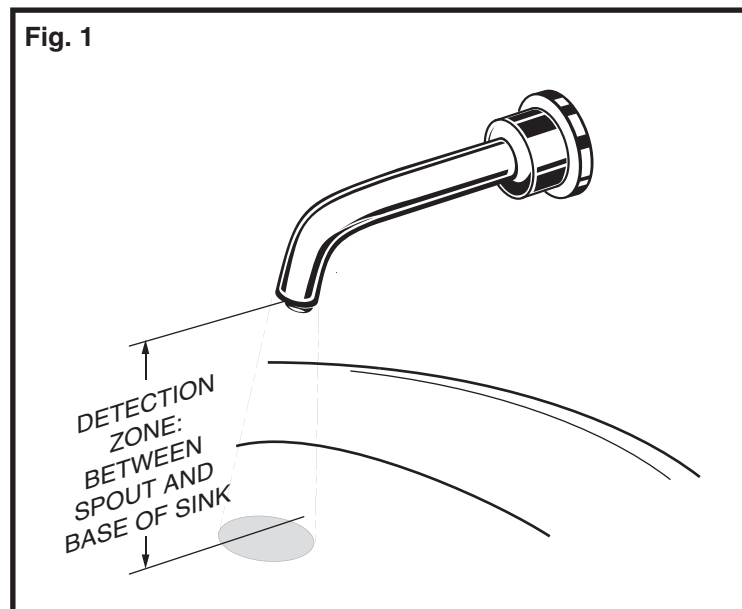

B HOW TO INSTALL AND CHANGE BATTERY; Fig. 2

1. Remove COVER from CONTROL BOX (1).
2. Disconnect BATTERY HOLDER (3) from SENSOR CABLE (5).
3. Remove old BATTERY from BATTERY HOLDER (3). Install new BATTERY (2) making sure the terminal side is inserted first and shape of the battery follows the shape of the BATTERY HOLDER (3).

! Prior to making power connection, make sure detection zone is not obstructed. Sensor is self adjusting. Keep detection zone clear for 15 seconds after power is connected.

4. To change LONG LIFE POWER PACK (4), unplug and replace with new Power Pack.
5. Reconnect BATTERY HOLDER (3) to SENSOR CABLE (5).
6. Replace CONTROL BOX COVER. Tighten cover screws firmly.

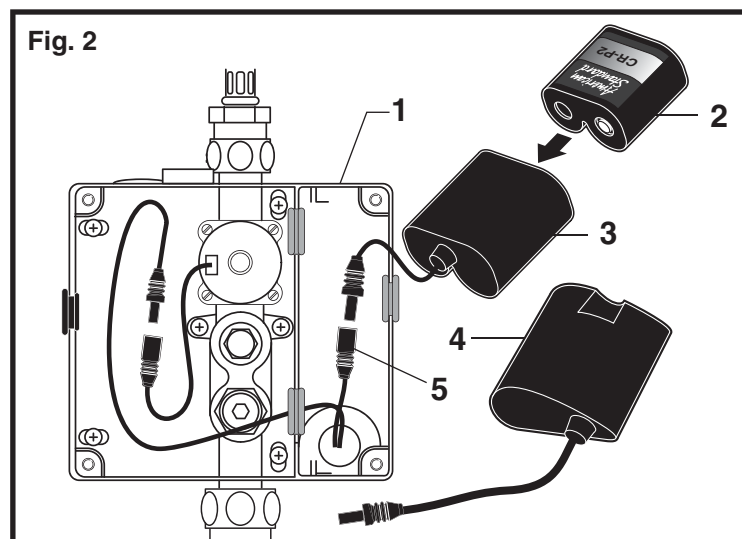

C HOW TO CLEAN FILTER ASSEMBLY; Fig. 3

CAUTION Before opening CONTROL BOX disconnect AC power supply.

1. Remove CONTROL BOX COVER.
2. Close SUPPLY STOP (13) with 4mm Hex wrench.
Note: Activate sensor to keep water flowing out of faucet while shutting off.
3. Unthread FILTER ASSEMBLY (6) using a 7/16" socket.
4. Pull out the FILTER ASSEMBLY (6), remove and clean white debris cup and filter screen.
5. Install the FILTER ASSEMBLY (6) back in its place and tighten with a 7/16" socket.

Caution: Do not over tighten.

6. Open SUPPLY STOP (13) with 4mm Hex wrench.
7. Replace CONTROL BOX COVER. Tighten cover screws firmly.

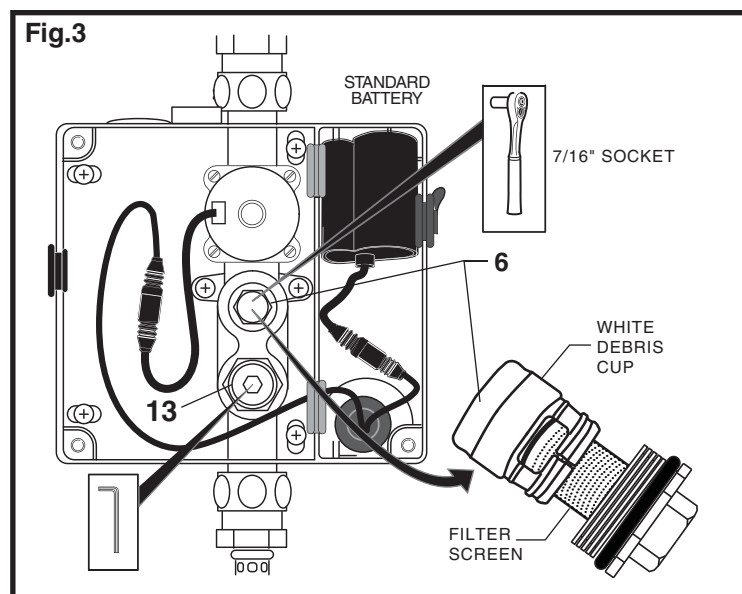

D HOW TO CLEAN AND REMOVE THE AERATOR OR SPRAY; Fig. 4

1. Remove AERATOR or SPRAY HOUSING (7) with KEY supplied with faucet.
2. Remove AERATOR or SPRAY (8) from HOUSING (7).
3. Clean the AERATOR or SPRAY SCREEN (9).
4. Reassemble and install into spout end. Be sure the black seal washer is in place.

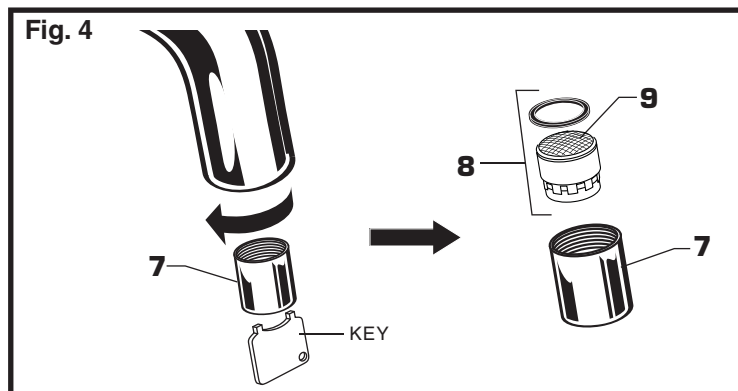

E HOW TO CLEAN FLOW REGULATOR; Fig. 5

1. Remove SUPPLY HOSE (10) from SPOUT ELBOW ASSEMBLY (11). Pull out FLOW REGULATOR (12) from SPOUT ELBOW ASSEMBLY (11).
2. Clean FLOW REGULATOR (12). Replace FLOW REGULATOR (12) and reassemble SUPPLY HOSE (10) to SPOUT ELBOW ASSEMBLY (11).

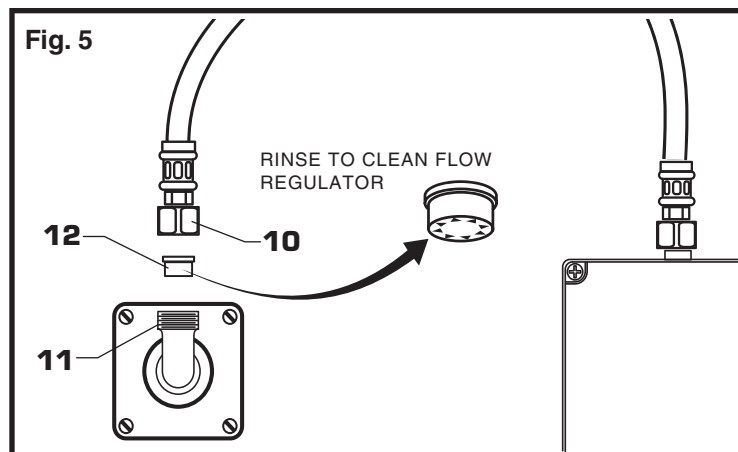

F GENERAL CLEANING; Fig. 5

1. Only use a damp, soft cloth to clean the spout and the sensor.
2. For tougher dirt, use a soft cloth with diluted dish washing detergent. Wipe the area using a wet cloth and dry using a soft cloth.



CAUTION

Do not scratch the sensor when cleaning.
Avoid using any abrasives or harsh detergents or chemicals.

FAQ'S

Q: How will I know if the battery needs to be replaced?

A: Valve will not open and sensor will continuously blink 2 times interrupted by a pause for up to 7 days.

Q: Why has the flow rate of the faucet reduced significantly?

A: The filter assembly, flow regulator or areator/spray may be clogged. Check and clean. Refer to Start-up/Maintenance, sections C, D and E.

Q: Why doesn't the water flow out of faucet when I'm within the sensor detection zone?

A: Battery may need replacement. Check. If sensor continuously blinks 2 times interrupted by pause, replace battery or call (855) 752-9259.

Q: What is the normal operating pressure range?

A: Faucet will operate with supply pressures ranging from 20-80 psi.

TROUBLESHOOTING FLOW CHARTS

UNIT DOES NOT FUNCTION

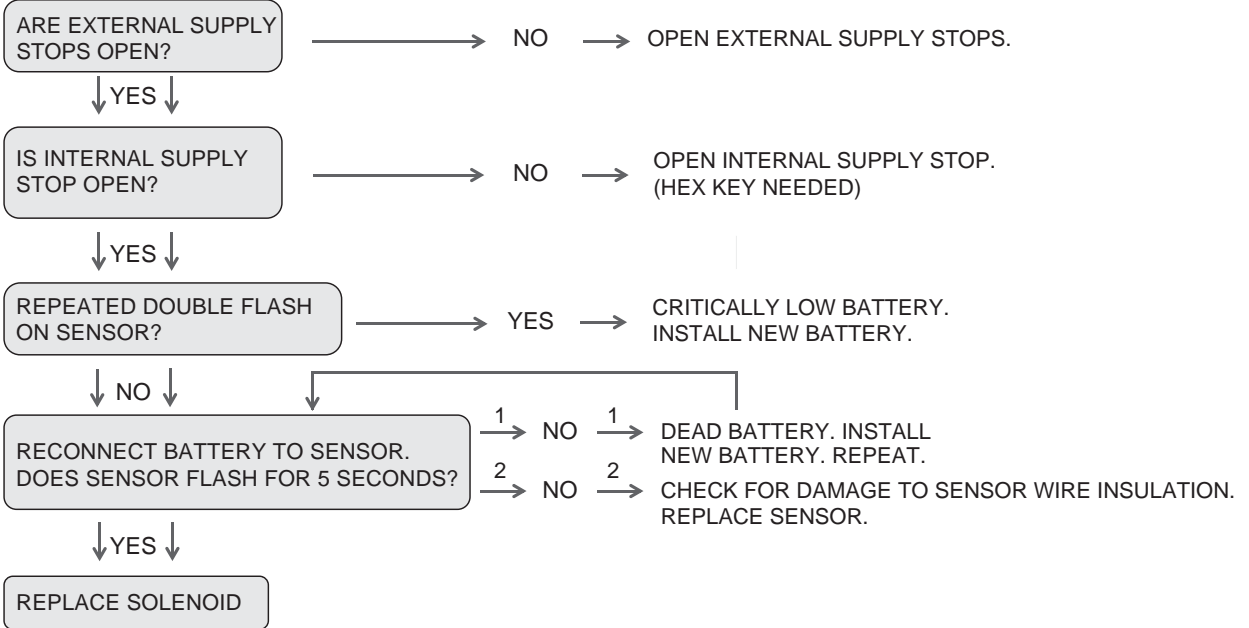

WATER IS CONTINUOUSLY RUNNING

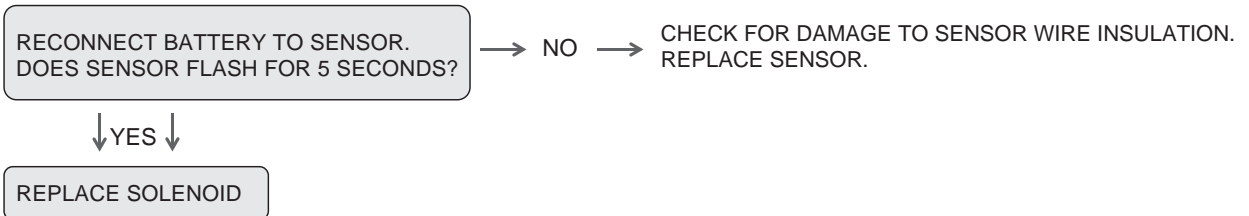

LOW FLOW ISSUES

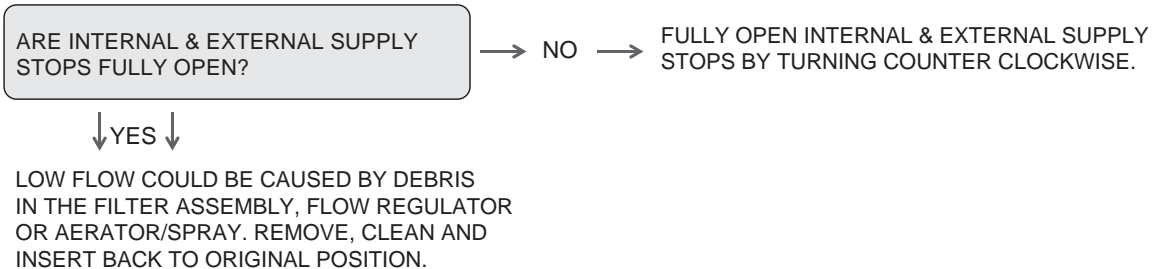

HOT LINE FOR HELP
For toll-free information and answers to your questions, call:
(844) CRT-TEAM / (844) 278-8326
Mon. - Fri. 8:00 a.m. to 8:00 p.m. EST Saturday 10:00 a.m. to 4:00 p.m. EST
IN MEXICO 01-800-839-1200
IN CANADA 1-800-387-0369 (TORONTO 1-905-306-1093)
Weekdays 8:00 a.m. to 7:00 p.m. EST

Product names listed herein are trademarks of AS America, Inc. ©2015

To learn more about American Standard Selectronic® Products visit our website at:
www.americanstandard-us.com or e-mail us at: CRTTEAM@americanstandard.com