

BABY DEVORO™ FloWise® 10" HIGH ROUND FRONT

2282.001

- Floor mount flushometer valve toilet
- Vitreous china
- High Efficiency, Low Consumption.
Operates in the range of 1.28 gpf to 1.6 gpf (4.9 Lpf to 6.0 Lpf)
- Meets definition of HET (High Efficiency Toilet) when used with a 1.28 gpf high efficiency flush valve
- 10-1/4" rim height
- 10" roughing-in
- Round front bowl
- Siphon jet action
- Fully glazed trapway
- 1-1/2" inlet spud
- 2 color-matched bolt caps
- 100% factory flush tested

Component parts:

- 047007-0070A** Inlet spud (furnished with bowl)
- 481310-100** Bolt caps with retainers (furnished with bowl)

Nominal Dimensions:

595 x 347 x 260mm
 (23-1/2" x 13-1/8" x 10-1/4")

Recommended working pressure – between 25 psi at valve when flushing and 80 psi static

Fixture only, less seat, bolt caps, and flush valve

Compliance Certifications -

Meets or Exceeds the Following Specifications:
 • ASME A112.19.2-2008 / CSA B45.1-08 for Vitreous China Fixtures

System MaP* Score:

- 800 grams of miso @ 1.28 gpf

* Maximum Performance (MaP) testing performed by IAPMO R&T Lab. MaP Report conducted by Veritec Consulting, Inc. and Koeller and Company.

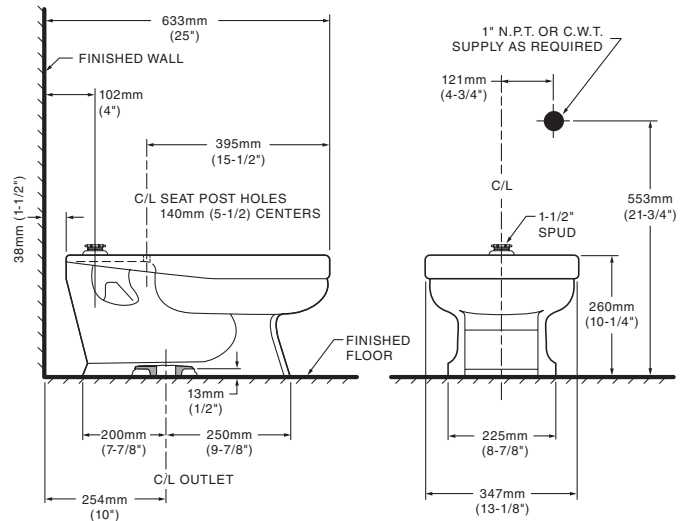

To Be Specified:

- Color: White
- Seat: Olsonite #126-CC open front seat less cover
- Seat: Church #1580C open front seat less cover
- Alternate Seat:
 - American Standard 5385.010 seat and cover
- Flush Valve
 - 1.6 gpf:
 - Sensor-Operated: American Standard Selectronic® DC Power #6065.161.002 (Top Spud)
 - Manual: American Standard #6047.161.002 (Top Spud)
 - 1.28 gpf:
 - Sensor-Operated: American Standard Selectronic® DC Power #6065.121.002 (Top Spud)
 - Manual: American Standard #6047.121.002 (Top Spud)

NOTES:

TO COMPLY WITH AREA CODE GOVERNING THE HEIGHT OF VACUUM BREAKER ON FLUSH VALVE, THE PLUMBER MUST VERIFY DIMENSIONS SHOWN FOR SUPPLY ROUGHING. FLUSH VALVE NOT INCLUDED AND MUST BE ORDERED SEPARATELY. THIS TOILET IS DESIGNED TO ROUGH-IN AT A MINIMUM DIMENSION OF 254MM (10") FROM FINISHED WALL TO C/L OF OUTLET.

IMPORTANT: Dimensions of fixtures are nominal and may vary within the range of tolerances established by ANSI Standard A112.19.2. These measurements are subject to change or cancellation. No responsibility is assumed for use of superseded or voided pages.



SELECTRONIC™ TOILET FLUSH VALVE
BATTERY POWERED, SENSOR OPERATED, 1.6 GPF



GENERAL DESCRIPTION:

Exposed, Battery Powered, Sensor Operated Selectronic™ Water Closet Flush Valve for floor-mounted or wall-hung 1-1/2" top spud bowls.

Inlet includes 1" I.P.S. angle stop with back-flow protection, vandal-resistant cap, sweat solder kit, cover tube and wall flange.

Outlet includes 1-1/2" vacuum breaker with adjustable tailpiece, spud coupling and flange.

PRODUCT FEATURES:

- Electronic flush valve with Selectronic™ proximity system for "Hands Free" operation
- Self-Cleaning Piston operation helps prevent clogging and reduces maintenance
- Positive seal ensures leak-free performance
- Fully mechanical Manual Override Button can flush toilet during a power outage
- Range can be adjusted manually or by remote control
- Sensor & electronic controls are fully enclosed and water resistant
- Automatically flushes after 24 hours of non-use to maintain trap seal
- Safety timer helps prevent vandalism by turning off the valve if sensor is covered for more than 1 minute
- 3-second Flush Delay
- Low Battery indicator
- Battery can be changed without turning off the water
- Factory-installed 6V lithium battery included
- Can be installed left or right-handed
- ADA compliant

MODEL NUMBER:

- ❑ **6065.161.002** Flush Valve for 11-1/2" Supply C/L to top of bowl, 1.6 gpf
- ❑ **6065.162.002** Flush Valve for 27" Supply C/L to top of bowl, 1.6 gpf
- ❑ **6065.565.002** Retrofit for Existing Flush Valves, 1.6 gpf. Replaces industry standard manual and electronic valves. Does not include the vacuum breaker assembly, angle stop or sweat solder kit.

OPERATING PRESSURE:

Overall Range: 20-125 psi**

Recommended: 25 psi (flowing)-80 psi (static)

FLOW REQUIREMENT:

25gpm (94.6 L/min.)

** Water pressure over 80 psi is not recommended for most plumbing fixtures.

BATTERY LIFE:

Up to 4-year life (approx. 200,000 cycles)

ACCESSORIES:

- Cast wall flanges (3/4", 1" & 1-1/2")
- Solid ring pipe supports (2-1/2" & 6" C-E)
- Split ring pipe supports (2-1/2" & 6" C-E)

**TYPICAL WATER CLOSET INSTALLATION:
 AFWALL™ TOILET SHOWN**

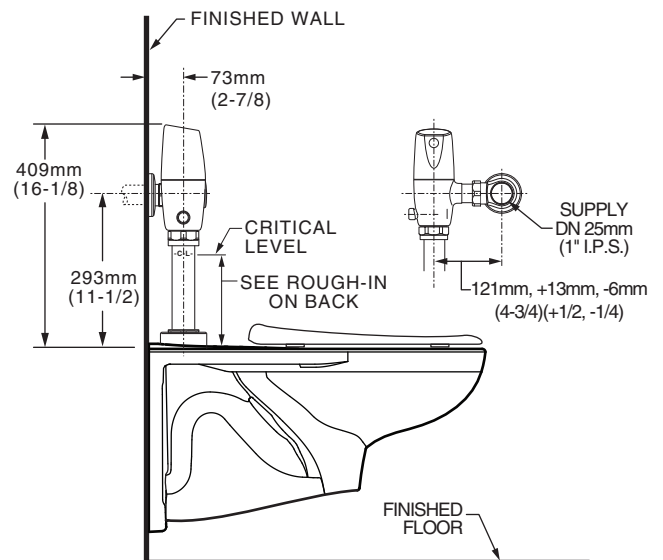

RECOMMENDED SPECIFICATION:

Electronic proximity infrared sensor activated toilet flush valve shall feature self-cleaning piston valve. Includes a fully mechanical manual over-ride that can provide a complete flush without battery power. Includes cast brass valve body and metal cover with chrome finish, vandal resistant stop cap and lithium battery. Angle stop with back-flow protection and vacuum breaker included. 1.6 gpf / 6.0 Lpf. Flush valve shall be American Standard Model # 6065.16_.002.

LISTINGS:

- ASSE 1037
- ANSI/ASME A112.19.2
- ADA Compliant

Roughing-in Dimensions

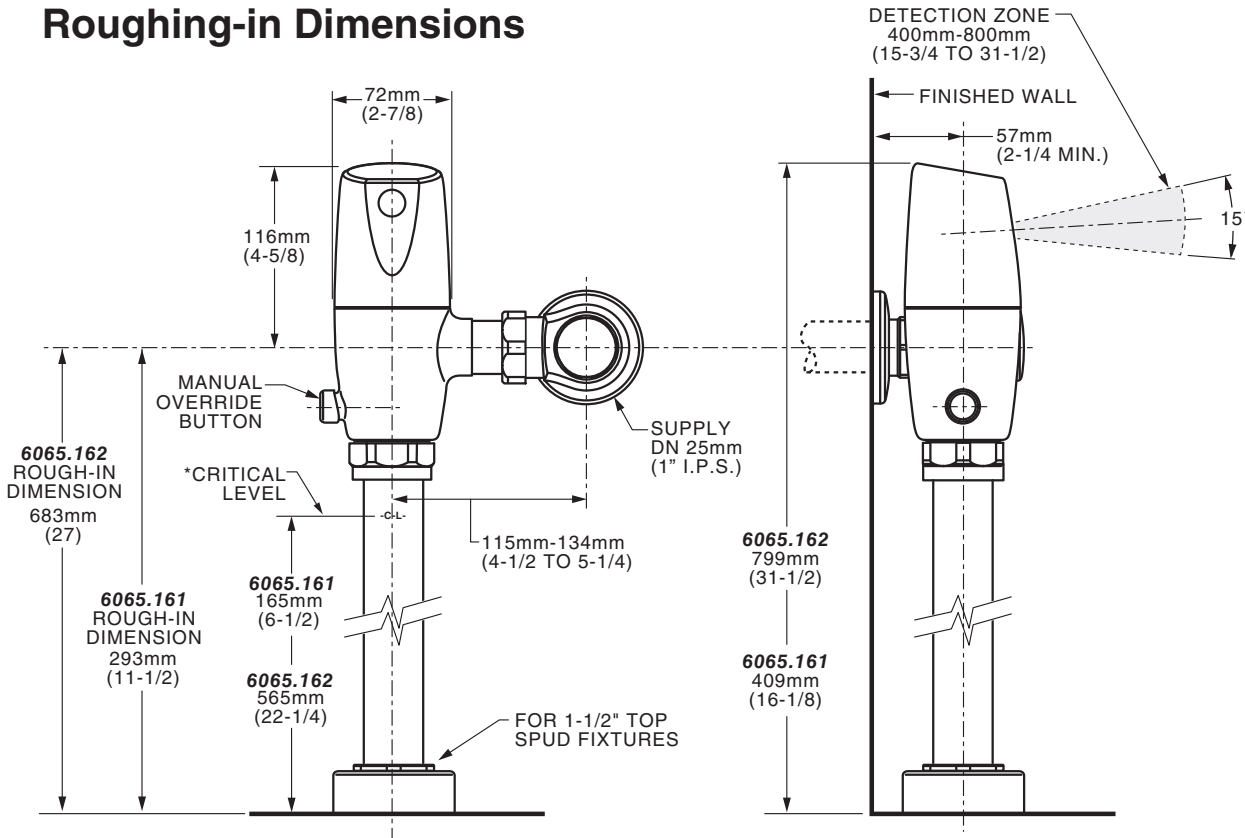

*Note: The Critical Line (-C-L-) on Vacuum Breaker must typically be 6" (152mm) above fixture. Consult Codes for details.

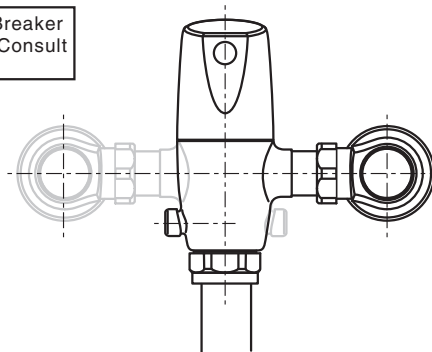

Right or Left Hand Installation